



**Sistemas puertas correderas**  
Sliding door fittings  
Systèmes portes coulissantes

# GLASS

 **saheco**

# ÍNDICE | INDEX | INDICE

## MUEBLES Y ARMARIOS | FURNITURE AND WARDROBE SYSTEMS | MEUBLES ET PLACARDS POSÉES

### CORREDERAS | SLIDING | COULISSANTES

DUPLO GLASS SV-45 | SV-85 45 - 85 kg

## MAMPARAS DE DUCHA | SHOWER ENCLOSURES | PAROI DE DOUCHE

### CORREDERAS | SLIDING | COULISSANTES

VAHO GLASS SV-X50 50 kg

GUIBLI GLASS SV- | GUIBLI SFERA | SV- | GUIBLI CUADRO 60 kg

HYDRO GLASS SV-HYDRO 80 kg

## MAMPARAS DIVISORIAS | DIVIDING ENCLOSURES | ENVELOPPES DIVISÉS

### FIJAS | FIXED | FIXES

ROOM GLASS SV-IT10

## DIVISIONES Y PUERTAS DE PASO | INTERNAL DIVIDERS AND DOORS | DIVISIONS ET PORTES D'ACCÈS

### CORREDERAS | SLIDING | COULISSANTES

ECO GLASS SV-E40 | SV-E75 40 - 75 kg

ESSENTIAL GLASS SV-A40 | SV-A60 EASY | SV-P70 EASY | SV-A90 | SV-A90 EASY 40 - 60 - 70 - 90 kg

SV-A110 | SV-P140 | SV-A160 110 - 160 kg

SV-A300 | SV-LA300 300 kg

BLOQ GLASS SV-Q60 | SV-Q110 60 - 110 kg

COMPACT GLASS SV-X70 70 kg  
SV-X110 + 110 kg  
SELFCLOSE SV-X150 150 kg

### CORREDERAS AUTOMÁTICAS | AUTOMATIC SLIDING DOORS | COULISSANTES

LEVIT GLASS SV-LEVIT 80kg

### TELESCÓPICAS SINCRO | SINCRO TELESCOPIC | TÉLÉSCOPIQUES SINCRO

MULTIPLO GLASS SV-SINCRO | SV-T-PROGRESIVA | SV-T-PROGRESIVA SINCRO 60 - 125 kg

MULTIPLO BLOQ GLASS SV-SINCRO Q110 55 - 110 kg

MULTIPLO COMPACT GLASS SV-SINCRO X110 110 kg  
SV-T-PRO X110 110 kg

### ACCESORIOS | ACCESSORIES | ACCESSOIRES

CERRADURAS | LOCKS | SERRURES

TIRADORES | HANDLES | POIGNÉES

## CERRAMIENTOS MÓVILES | MOBILE ENCLOSURES | CLOISONS MOBILES

### APILABLES | STACKABLE | EMPILABLES

PARKING GLASS SV-P40 40 kg  
SV-P150 150 kg  
SV-P250 250 kg

### PLEGABLES | FOLDING | PLIANTES

PLICAT GLASS SV-A101D 100 kg por par de hojas  
per pair of panels | par paire de panneaux  
SV-I100D 100 kg por par de hojas  
per pair of panels | par paire de panneaux

## ACCESORIOS | ACCESSORIES | ACCESSOIRES

### PERFILERÍA PERIMETRAL | PERIMETER PROFILES | PROFILS DE PÉRIMÈTRE

FRAME GLASS

FRAME FLAT GLASS

## DEMOSTRATIVOS | DISPLAY STAND | PRÉSENTOIR

### DEMOSTRATIVOS | DISPLAY STANDS | PRÉSENTOIRS

### MALETAS DEMOSTRATIVAS | COMMERCIAL SUITCASES | VALISES COMMERCIALES



# Duplo Glass

SV-45 | SV-85

# DUPLO GLASS

BIBLIOTECA  
DE DESCARGAS



DOWNLOADS LIBRARY |  
BIBLIOTHÈQUE  
TÉLÉCHARGEMENTS

## ES

SV-45 / SV-85 son dos sistemas ideales para armarios, divisiones y puertas de uso doméstico o comercial de 45 y 85Kg de peso por hoja respectivamente. Destacan por su perfil doble, el cual alberga 2 puertas en el mínimo espacio.

Para de hojas de 45Kg la distancia mínima entre puertas es de solo 16mm (para vidrios de 10mm de espesor) y de 18mm (para vidrios de 8mm de espesor), y para hojas de 85Kg la distancia mínima entre puertas de 18mm (para vidrios de 8mm de espesor) y de 20mm (para vidrios de 10mm de espesor). Pinzas de alta calidad y roldanas con rodamiento a bolas para asegurar un funcionamiento suave y de deslizamiento silencioso. Regulación vertical de  $\pm 2$ mm y guiador inferior ajustable para permitir la instalación de vidrios de diferentes grosores (8-10mm). No se requiere mecanización del vidrio.

## EN

SV-45 / SV-85 – high quality systems ideal for wardrobes and light to medium weight doors in domestic or commercial use, supporting weights of 45kg and 85kg per leaf, respectively. Only suitable for MULTIPLE doors which BI-PASS, the essence of the system is a pre-formed double top track which means the lateral gap between the doors is minimised.

For 45Kg leaf doors, the minimum distance between doors is only 16mm (for 10mm thick glass) and 18mm (for 8mm thick glass). For 85Kg leaf doors, the minimum distance between doors is 18mm (for 8mm thick glass) and 20mm (for 10mm thick glass). The top hangers complete with sealed ball race bearings are connected to the glass doors (no drilling required) via high quality glass clamps, and ensure a smooth and quiet sliding action. The hangers also incorporate a useful height adjustment feature  $\pm 2$ mm, and the system is completed with adjustable clear threshold bottom guides (for glass thickness 8-10mm) and a full width bottom guide channel complete with a brush draught excluder, as an alternative bottom guiding option. No drilling of glass required.

## FR

SV-45 / SV-85 sont deux systèmes idéaux pour les armoires, les cloisons et les portes à usage domestique ou commercial pesant respectivement 45 et 85 Kg par feuille. Ils se distinguent par leur profil double, qui permet d'accueillir 2 portes dans un espace minimal.

Pour les feuilles de 45Kg, la distance minimale entre les portes est seulement de 16 mm (pour des vitres de 10 mm d'épaisseur) et de 18 mm (pour des vitres de 8 mm d'épaisseur). Pour les feuilles de 85Kg, la distance minimale entre les portes est de 18 mm (pour des vitres de 8 mm d'épaisseur) et de 20 mm (pour des vitres de 10 mm d'épaisseur). Des pinces de haute qualité et des roulettes à roulement à billes assurent un fonctionnement fluide et un coulissement silencieux. Réglage vertical de  $\pm 2$  mm et guide inférieur réglable pour permettre l'installation de vitres de différentes épaisseurs (8-10 mm). Aucune mécanisation du verre n'est nécessaire.





### Características técnicas

Technical characteristics | Caractéristiques techniques

### Perfilería Profiles | Profils



48x32 mm



20x15 mm

### Especificaciones Specifications | Spécification

SV-45



8-10 mm 16-18 mm

SV-85

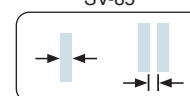

8-10 mm 18-20 mm



RODAMIENTO A BOLAS  
BALL BEARING  
ROULEMENT À BILLES

### Peso Weight | Poids

45 kg	99 lb
85 kg	188 lb

### Producto certificado

Certificated product | Produit certifié



**Variantes de instalación**

Installation possibilities | Variantes d'installation

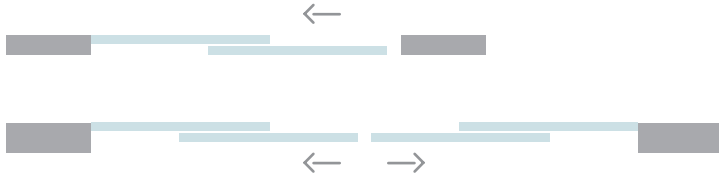

**Sección tipo**

Cros-section | Section type (Cotas en mm | Dimensions in mm | Dimensions en mm)

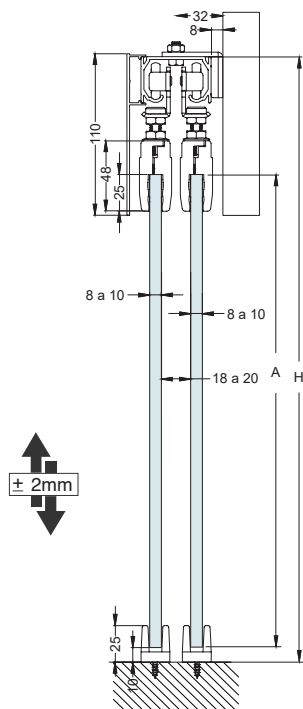

A= H-90

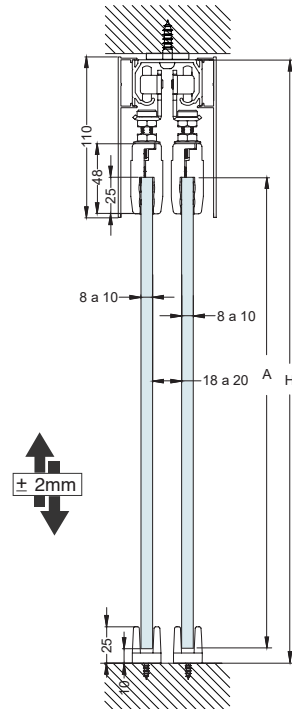

A= H-93



## Componentes

Components | Composants

PERFILERÍA   PROFILES   PROFILS		Acabado	Cód.		
	Perfil superior Top track Rail supérieur  48x32mm	MF	00 85 20 00 85 30 00 85 50	2 m 3 m 5 m	1 perfil 1 profile 1 profil
	Perfil inferior con burlete de 8-10-12mm Bottom track with brush of 8-10-12mm Rail inférieur avec bourrelet de 8-10-12mm  20x15mm	S	00 41 22 00 41 32 00 41 62	2 m 3 m 6 m	1 perfil 1 profile 1 profil
JUEGOS   SETS   JEUX		Acabado	Cód.		
	Juego de accesorios <b>SV-45</b> SV-45 Fitting set Garniture SV-45  45kg RODAMIENTO A BOLAS BALL BEARING ROULEMENT À BILLES		00 46 01		1 juego 1 set 1 jeu
	Juego de accesorios <b>SV-85</b> SV-85 Fitting set Garniture SV-85  85kg RODAMIENTO A BOLAS BALL BEARING ROULEMENT À BILLES		00 96 00		1 juego 1 set 1 jeu
ACCESORIOS   ACCESSORIES   ACCESSOIRES		Acabado	Cód.		
	Tapeta Pelmet cover Cache 110mm	S BL	0 104 23 0 104 33 0 104 53 0 104 24 0 104 34 0 104 54	2 m 3 m 5 m 2 m 3 m 5 m	2 perfiles 2 profiles 2 profils
	Esquina tapeta Pelmet cover corner Coin cache	PPS	0 103 02		2 piezas 2 pièces 2 pièces

**MF** Aluminio natural  
Mill finish aluminium  
Aluminium brut







**S** Aluminio anodizado plata mate  
Satin anodized aluminium  
Aluminium anodisé argent

**BL** Aluminio lacado negro  
Black lacquered aluminium  
Aluminium anodisé laqué noir

**PPS** Plástico pintado plata  
Plastic painted silver  
PVC finition peinture argent

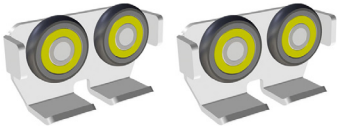
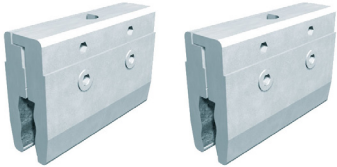
## Componentes

Components | Composants

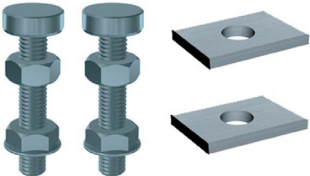
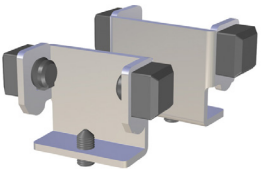
ACCESORIOS   ACCESSORIES   ACCESSOIRES		Acabado	Cód.		
	Juego roldanas Roller set Jeu de galets		00 96 55		5 juegos 5 set 5 jeu
	Juego pinza <b>SV-45</b> regulable <b>SV-1</b> SV-45 SV-1 Adjustable clamp set Jeu de pince SV-45 réglable SV-1  SV-1		00 40 58		5 juego 5 set 5 jeu
	Juego pinza <b>SV-85</b> regulable <b>SV-2</b> SV-85 SV-2 Adjustable clamp set Jeu de pince SV-85 réglable SV-2  SV-2		00 60 58		1 juego 1 set 1 jeu
	Juego de tornillos de ajuste Adjustment screw set Jeu vis porteuse avec écrou		00 46 56		5 juegos 5 set 5 jeu
	Juego tope freno (derecha e izquierda) Brake stopper set (left and right) Jeu butée d'arrêt (droit et gauche)		00 96 57		5 juegos 5 set 5 jeu



## Componentes

Components | Composants

PERFILERÍA   PROFILES   PROFILS	Acabado	Cód.		
 <p>Soporte pared Wall support Support mur</p>		00 96 58 <sup>1</sup>		25 piezas 25 pieces 25 pièces
 <p>Guiador inferior plástico para vidrio de 8-12mm Plastic bottom guide for glass of 8-12mm Guide inférieur plastique pour verre de 8-12mm</p>		00 40 57		25 piezas 25 pieces 25 pièces
 <p>Guiador inferior para vidrio de 8-14 mm Bottom guide for glass of 8-14mm Guide inférieur pour verre 8-14mm</p>		0 155 73		10 piezas 10 pieces 10 pièces
 <p>Separador aluminio Aluminium separator Séparateur aluminium</p>		00 60 61 <sup>1</sup>		25 piezas 25 pieces 25 pièces
 <p>Soporte tapeta Pelmet cover support Support cache</p>		00 66 59		10 piezas 10 pieces 10 pièces

<sup>1</sup>Para las familias que incorporen soporte pared/separador con perfilera de 2 m, 3 m o 5 m, aplicar uno por cada taladro | <sup>1</sup>For sets that incorporate a wall support/separator with 2m, 3m, 5m or 6m profiling, apply one for each drill hole | <sup>1</sup>Pour les familles intégrant un support mural/séparateur avec profils de 2m, 3m, 5m ou 6m, appliquer un support pour chaque trou percé.

2 m - 10 soportes pared | supports wall | supports muraux 3 m - 15 soportes pared | supports wall | supports muraux 5 m - 25 soportes pared | supports wall | supports muraux 2 m - 10 separadores | separators | séparateurs 3 m - 15 separadores | separators | séparateurs 5 m - 25 separadores | separators | séparateurs



# Vaho Glass

SV-X50

# VAHO GLASS



ES

## MÍNIMO ESPACIO, MÁXIMO CONFORT

**SV-X50 es un sistema de puerta corredera para duchas para paneles de vidrio sin marco que combina las últimas novedades tecnológicas con un atractivo diseño minimalista.**

**1. Perfil** corredero de aluminio **compacto** que oculta todos los mecanismos dentro del mismo; consiguiendo así, un inmejorable aspecto estético. **2.** Disponible en **distintos acabados:** aluminio Inox repulido, aluminio pulido cromado, aluminio dorado cepillado y aluminio anodizado negro mate. **3. Montaje** pared-pared, pared-vidrio, vidrio-vidrio y angular (90°) **4.** Apto para **grosos de vidrio** de 8 y 10mm (8mm para angular). **5. Instalación fácil y rápida** gracias al acceso frontal a todas las regulaciones y componentes. **6. Rodamiento a bolas** para para una acción deslizante suave y segura. **7. Sistema de amortiguación SofTop doble:** gracias a la nueva tecnología de amortiguación recientemente desarrollada, el esfuerzo de apertura será mínimo, ya que conseguimos reducirlo hasta casi un 40%. Asimismo, tendremos un frenado suave y silencioso en los últimos 7cm del recorrido de cierre. El sistema de amortiguación SofTop doble, protegerá al sistema de daños por impacto, alargando así la vida útil del producto y con solo un mínimo de ancho puerta necesario de 630mm. **8. Certificado Applus+:** Grado de durabilidad 6: 100.000 ciclos de ensayo y Grado de corrosión 4 = 240h según norma EN1527 **9. Accesorios opcionales:** vierteaguas horizontal y juntas de estanqueidad que se quitan fácilmente para limpiar y/o cambiarlas.

EN

## MINIMUM SPACE, MAXIMUM COMFORT

**SV-X50 is a frameless sliding glass shower door system that combines the latest technological developments with an attractive minimalist design.**

**1.Compact** aluminum sliding **track** that conceals all the mechanisms; thus, achieving an unbeatable aesthetic appearance. **2.** Available in **different finishes:** brushed nickel aluminum, polished chrome aluminum, satin brass aluminum and matt black anodized aluminum. **3. Installation** wall-wall, wall-glass, glass-glass and angular (90°) **4.** Suitable for **glass thicknesses** of 8 and 10mm (only 8mm for angular) **5. Quick and easy installation** thanks to the frontal access to all components and its adjustments and regulations. **6. Ball bearing rollers** for a smooth and silent sliding action. **7. Double SofTop damping system:** thanks to the latest developed damping technology, the opening effort is minimal as it has been reduced by almost 40%. Likewise, a smooth and silent closing in the last 7cm of the sliding path is achieved. The double SofTop damping system protects the system from impact damage, thus extending the useful life of the product and with only a minimum door width of 630mm required. **8. Applus+ Certificate:** Durability grade 6: 100.000 test cycles and Corrosion grade 4 = 240h according to EN1527 standards. **9. Optional accessories:** horizontal water seals and sealing gaskets that can be easily removed for cleaning and/or changing.

FR

## ESPACE MINIMAL, CONFORT MAXIMAL

**SV-X50 est un système de porte de douche coulissante pour panneaux de verre sans cadre qui combine les dernières innovations technologiques avec un design minimaliste attrayant.**

**1. Profilé** coulissant **compact** en aluminium qui dissimule tous les mécanismes à l'intérieur, ce qui lui confère un aspect esthétique incomparable. **2.** Disponible en **différentes finitions:** aluminium poli nickelé, aluminium poli chromé, aluminium doré brossé et aluminium anodisé noir mat. **3. Installation** mur-mur, mur-verre, verre-verre et angulaire (90°) **4.** Convient pour des **épaisseurs de verre** de 8 et 10mm (8mm pour l'angulaire) **5. Installation rapide et facile** grâce à l'accès frontal à tous les réglages et composants. **6. Roulement à billes** pour une action coulissante en douceur et sûre. **7. Double système d'amortissement SofTop:** grâce à la nouvelle technologie d'amortissement récemment mise au point, l'effort d'ouverture est minimum et réduit de près de 40%. De plus, nous aurons un freinage en douceur et silencieux dans les 7 derniers centimètres du parcours de fermeture. Le double système d'amortissement SofTop protège le système contre les dommages causés par les chocs, ce qui prolonge la durée de vie du produit. Une largeur de porte minimale de 630mm suffit. **8. Certificat Applus+:** Degré de durabilité 6: 100.000 cycles d'essai et degré de corrosion 4 = 240h selon la norme EN1527. **9. Accessoires en option:** gouttière horizontale et joints d'étanchéité qui peuvent être facilement retirés pour être nettoyés et/ou remplacés.



Montaje pared-pared | mounting wall-to-wall | fixation mur-mur



### Características técnicas

Technical characteristics  
Caractéristiques techniques

### Tecnología y facilidad de montaje

Technology and ease of installation | Technologie et facilité d'assemblage

#### Perfilería Profiles | Profils

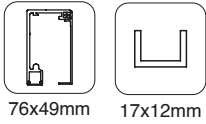

76x49mm 17x12mm

#### Especificaciones Specifications | Spécification

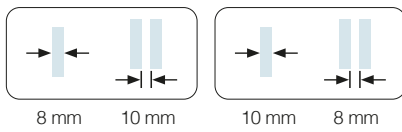

8 mm 10 mm 10 mm 8 mm



MÍN.450 mm

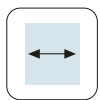

**SofTop Doble**  
MÍN.630 mm

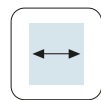

MÍN.450 mm  
MÁX.750 mm

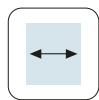

**SofTop Doble**  
MÍN.630 mm  
MÁX.750 mm

OPCIÓN 90° |  
90° OPTION | OPTION 90°

OPCIÓN 90° |  
90° OPTION | OPTION 90°



KIT DISPONIBLE  
| AVAILABLE



RODAMIENTO A BOLAS  
BALL BEARING  
ROULEMENT À BILLES

#### Peso Weight | Poids

50 kg

110 lb

OPCIÓN 90° | 90° OPTION | OPTION 90°

30 kg

66 lb

**OPCIÓN PARED DE VIDRIO CUANDO LA HOJA  
CORREDERA CIERRA CONTRA EL VIDRIO FIJO |  
GLASS WALL OPTION WHEN THE SLIDING PANEL  
CLOSES AGAINST THE FIXED GLASS. | OPTION DE  
PAROI EN VERRE LORSQUE LE PANNEAU COULIS-  
SANT SE FERME CONTRE LE VERRE FIXE.**

30 kg

66 lb

#### Producto certificado

Certificatd product | Produit certifié



Grado de durabilidad 6:  
100.000 ciclos de ensayo y  
Grado de corrosión 4 = 240h. |  
Durability grade 6: 100.000 test  
cycles and Corrosion grade 4  
= 240h. | Degré de durabilité 6:  
100.000 cycles d'essai et degré  
de corrosion 4 = 240h.

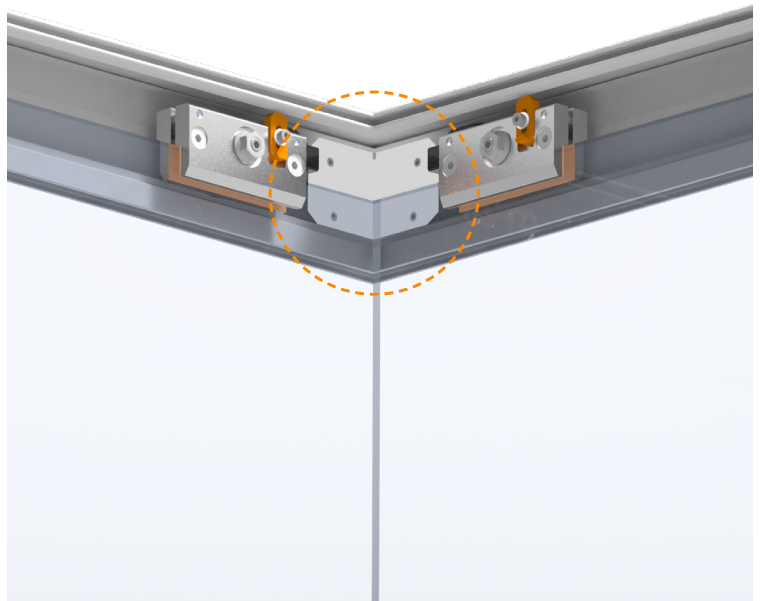
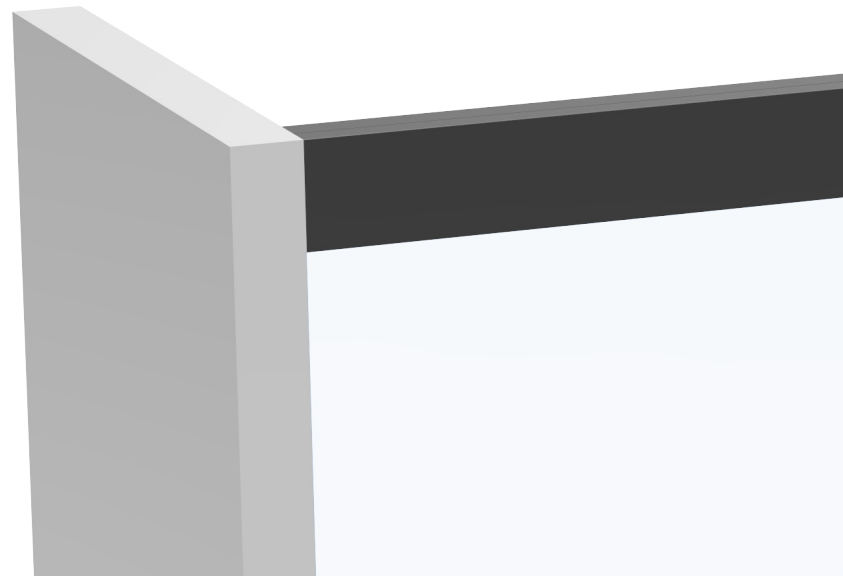

**IES | Conector angular** de fácil instalación ya que no requiere taladros. Diseñado para evitar la flexión del angular gracias a su gran capacidad de carga. La perfilera se suministra cortada a 45°. **ENI Angular connector** for easy installation as it does not require any drilling. Designed to avoid any possible bending of the angle thanks to its high load capacity. The profiles are supplied cut at 45°. **IFRI Le connecteur d'angle** est facile à installer car il ne nécessite aucun perçage. Conçu pour empêcher la flexion de l'angle en raison de sa capacité de charge élevée. Les profilés sont fournis coupés à 45°.



**IESI SOFTOP DOBLE:** gracias a la **nueva tecnología de amortiguación** recientemente desarrollada, el **esfuerzo de apertura** será mínimo, ya que **se reduce hasta casi un 40%**. Asimismo, ofrece un frenado suave y silencioso en los últimos 7cm del recorrido de cierre. Para instalaciones con solo un mínimo de ancho puerta necesario de 630mm. **IENI DOUBLE SOFTOP:** thanks to the **latest developed damping technology**, the **opening effort** is minimal as **it has been reduced by almost 40%**. Likewise, a smooth and silent closing in the last 7cm of the sliding path is achieved. The double SofTop damping system protects the system from impact damage, thus extending the useful life of the product and with only a minimum door width of 630mm required. **IFRI SOFTOP DOBLE :** grâce à la **nouvelle technologie d'amortissement** récemment mise au point, **l'effort d'ouverture** est minimum et **réduit de près de 40%**. Il offre également un freinage en douceur et silencieux dans les 7 derniers centimètres du parcours de fermeture. Pour les installations où seule une largeur de porte minimale de 630mm est requise.

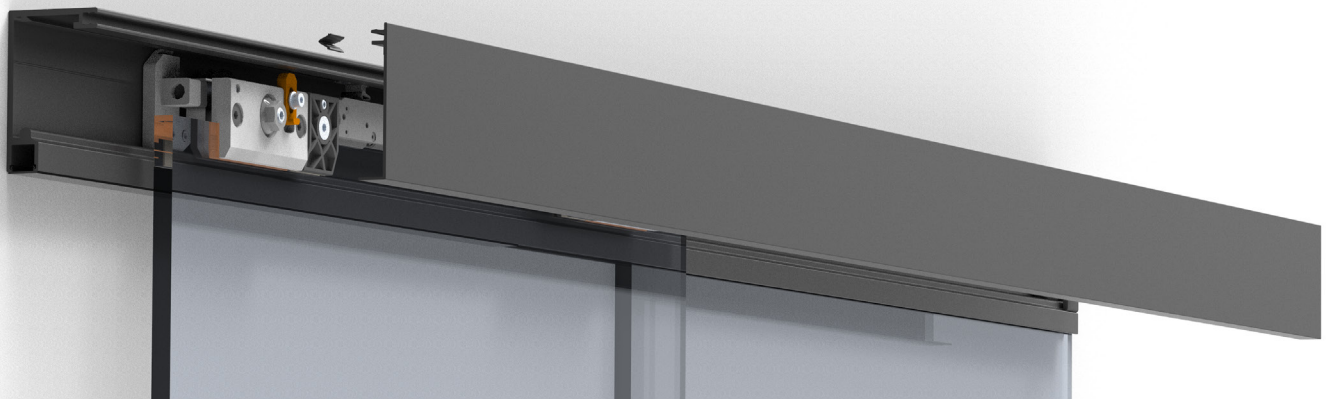

**IESI Acceso frontal a todas las regulaciones y componentes.** Tapeta con clipaje de apriete para ahorro de tiempo de instalación.  
**IENI Frontal access to all components and its adjustments and regulations.** The lateral top cover track is clipped to save installation time.  
**IFRI Accès frontal à tous les réglages et composants.** Bandeau de serrage à clipser pour une installation rapide.

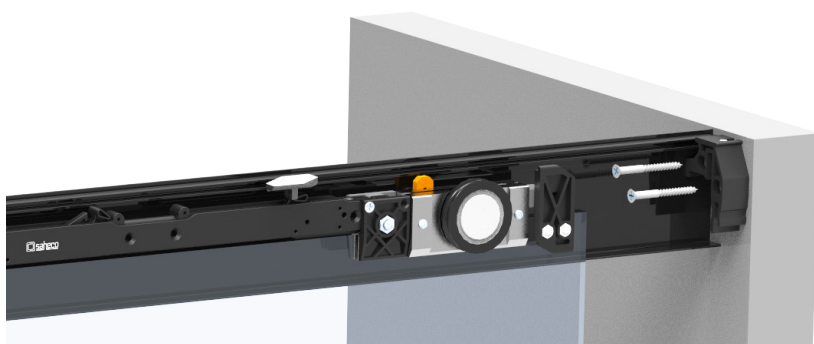

**IESI Soportes flotantes** a pared y vidrio ocultos. **IENI Hidden floating** wall and glass mounting **brackets**. **IFRI Supports muraux flottants** et verre dissimulé.



## Diseño compacto, estilo minimal

Compact and sleek design | Design compact, style minimaliste

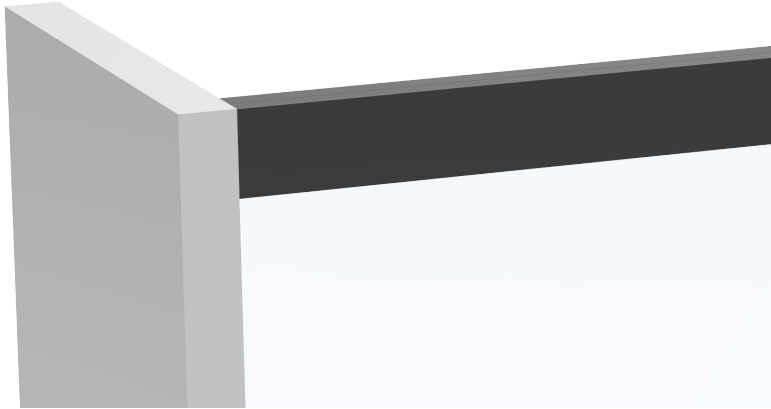

**ES** | Perfil liso y compacto (76x49mm) en distintos acabados disponibles que ofrece excelentes posibilidades de integración en cualquier tipo de diseño arquitectónico. **EN** | Smooth and compact track (76x49mm) in different finishes available that offers excellent possibilities for integration into any type of architectural design. **FR** | Profilé lisse et compact (76x49mm) en différentes finitions disponibles qui offre d'excellentes possibilités d'intégration dans tout type de conception architecturale.

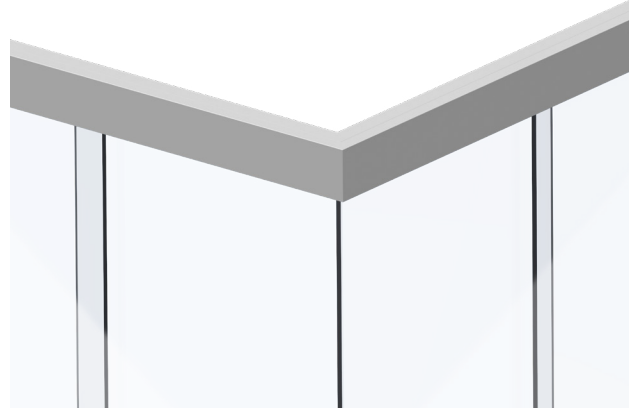

**ES** | Conector angular interno para la unión de los dos perfiles a 90°, dejando libre la superficie del perfil para un acabado limpio y lineal. **EN** | Internal angular connector for joining the two tracks at 90°, leaving the visible surface of the track with a clean and linear finish. **FR** | Connecteur d'angle interne pour joindre les deux profilés à 90°, laissant la surface du profilé libre pour une finition propre et linéaire.

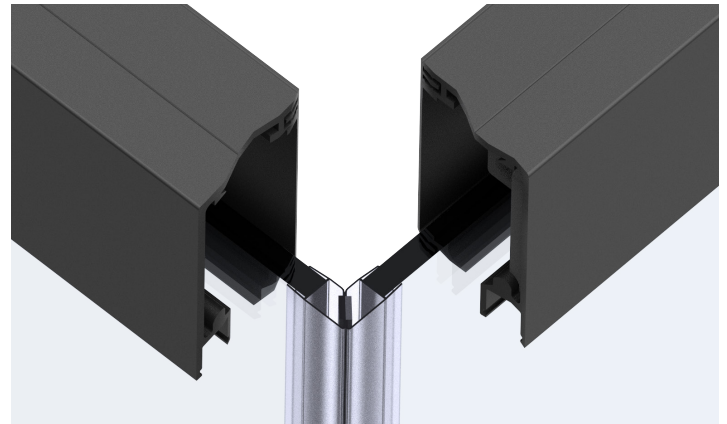
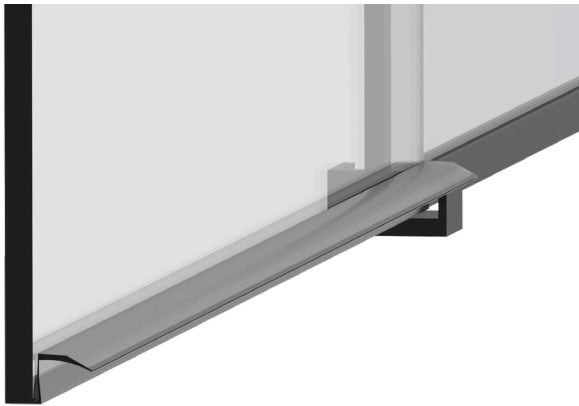

**ES** | Guiador inferior flotante SV-X50 para vidrio 8.10mm. Vierteaguas, salvacantos y juntas de estanqueidad disponibles, de fácil quita y pon para limpiar y/o cambiar. **EN** | Floating bottom guide SV-X50 for 8-10mm glass. Water seals, edge water seals and sealing gaskets available, easy-to-remove for cleaning and/or changing. **FR** | Guide inférieur flottant SV-X50 pour verre de 8 à 10 mm. Gouttière, joints d'étanchéité et profilés de finition sont disponibles, facile à enlever pour le nettoyage et/ou le remplacement.

## Acabados disponibles

Available finishes | Finitions disponibles



Aluminio Inox repulido  
Brushed nickel aluminium  
Aluminium polie nickel  
Brillante | Shiny | Brillant



Aluminio pulido cromado  
Polished chrome aluminium  
Aluminium polie chromé  
Brillante | Shiny | Brillant



Aluminio dorado cepillado  
Satin brass aluminium  
Aluminium doré brossé  
Brillante | Shiny | Brillant



Aluminio anodizado negro mate  
Matt black anodized aluminium  
Aluminium anodisé noir mat



**Montaje vidrio-pared** | mounting glass-to-wall | fixation verre-mur



**Montaje pared-pared** | mounting wall-to-wall | fixation mur-mur



**Montaje pared-pared. Angular 90°** | Mounting wall-to-wall. Angular 90° | Fixation mur-mur. Angulaire 90°



**Variantes de instalación**

Installation possibilities | Variantes d'installation

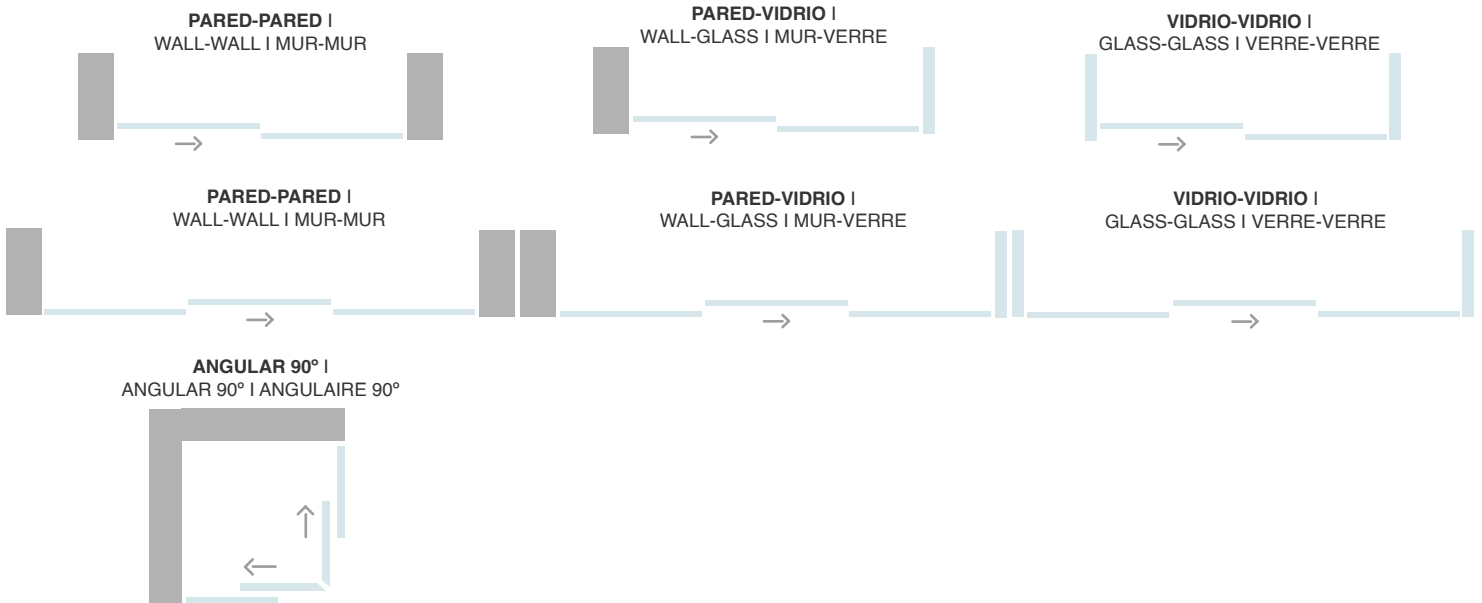

**Sección tipo**

Cross-section | Section type (Cotas en mm | Dimensions in mm | Dimensions en mm)

SV-X50 | SV-X50 | SV-X50 SV-X50 ANGULAR 90° | SV-X50 90° ANGLE | SV-X50 ANGLE 90°

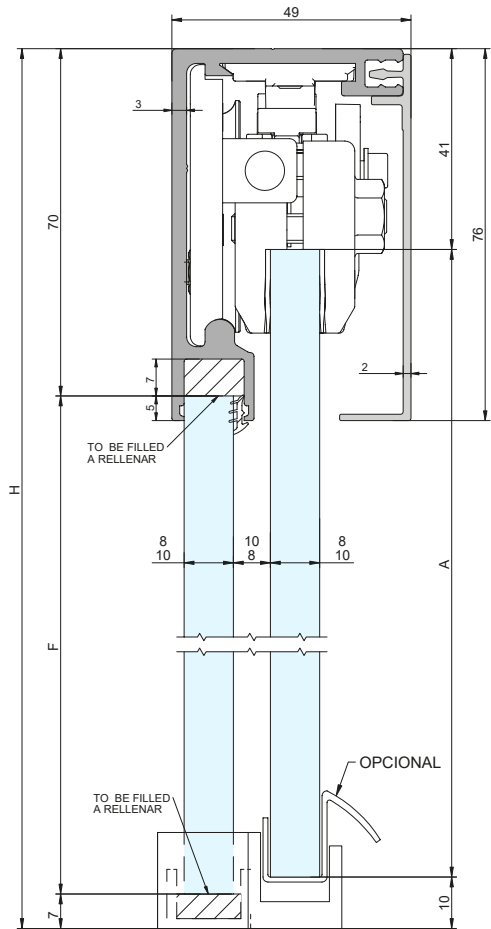

$F = H - 77$

$A = H - 51$

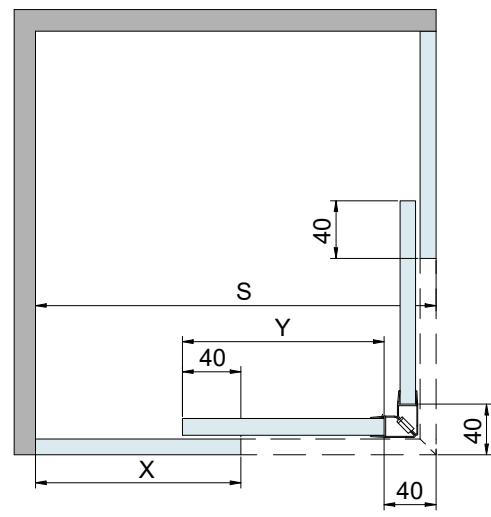

S=LONGITUD PERFIL / Track length / Longueur du profil

$X = S/2$   
 $Y = X$

ANGULAR 90°   90° CORNER   ANGLE 90°		Plato de ducha   Shower tray   Receveur de douche	Ancho de puerta   Door width   Largeur de porte	Peso máximo   Max. weight   Maximum poids
Sin Softop   Without Softop   Sans Softop	Min.	900x900	450	30 kg
	Máx.	1500x1500	750	
Con Softop   With Softop   Avec Softop	Min.	1260x1260	630	
	Máx.	1500x1500	750	

**Sección tipo**

Cross-section | Section type (Cotas en mm | Dimensions in mm | Dimensions en mm)

SV-X50 ANGULAR 90° | SV-X50 90° ANGLE | SV-X50 ANGLE 90°

**SECCIONES MÍNIMO ANCHO DE HOJA, OPCIÓN SOFTOP**  
 SECTION MINIMUM PANEL WIDTH, SOFTOP OPTION |  
 SECTIONS LARGEUR MINIMUM DE VANTAUX, OPTION SOFTOP

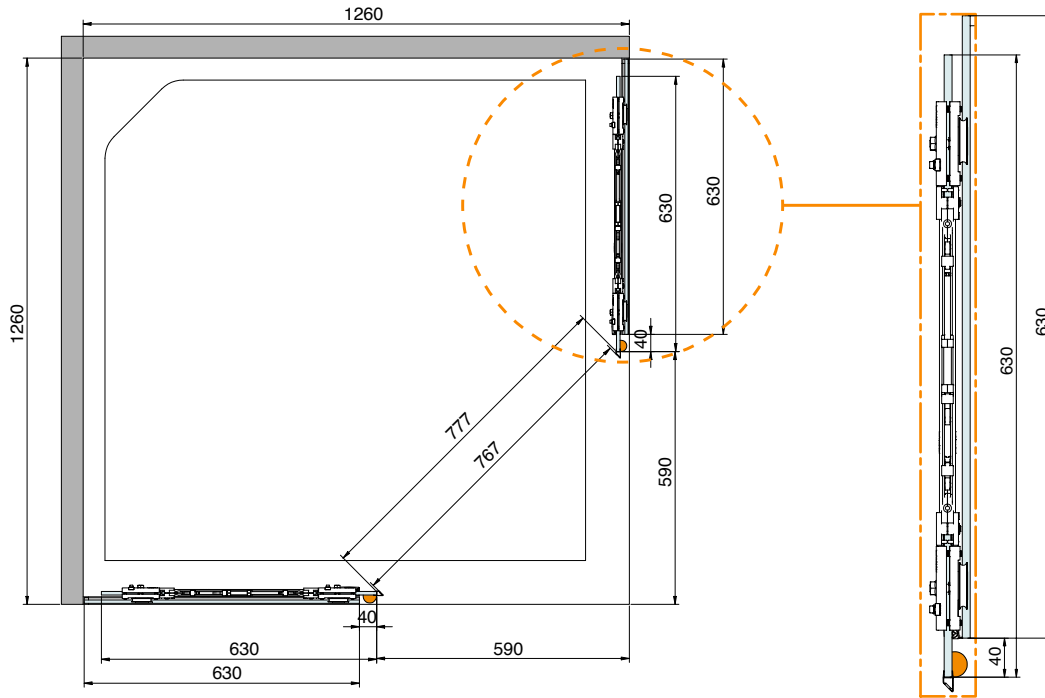



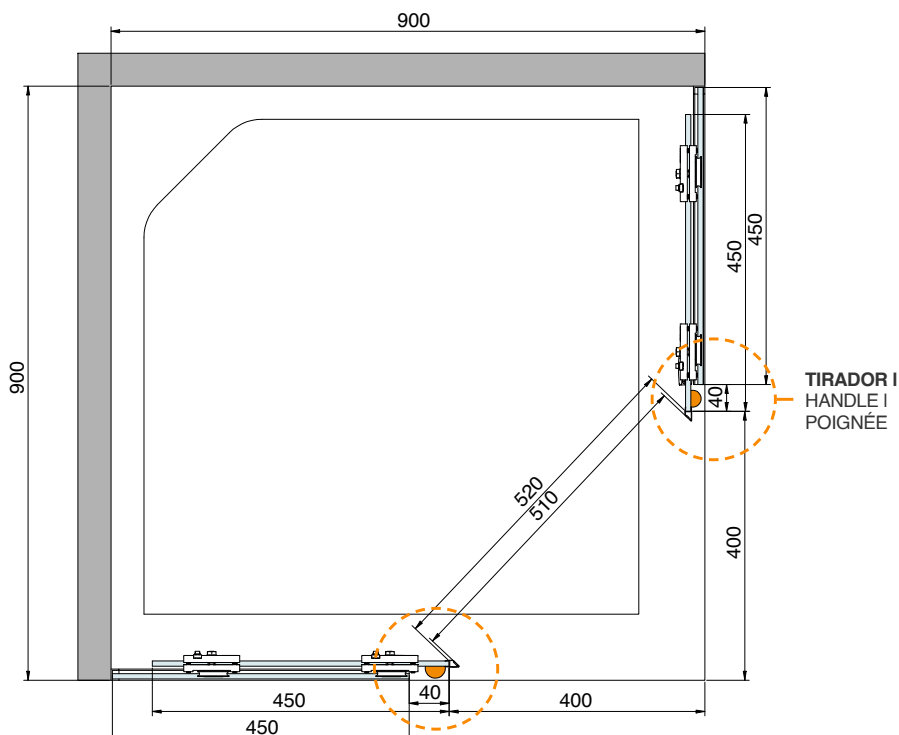





**SECCIONES MÍNIMO ANCHO DE HOJA, OPCIÓN SIN SOFTOP**  
 SECTION MINIMUM PANEL WIDTH, OPTION WITHOUT SOFTOP |  
 SECTIONS LARGEUR MINIMUM DE VANTAUX, OPTION SANS SOFTOP

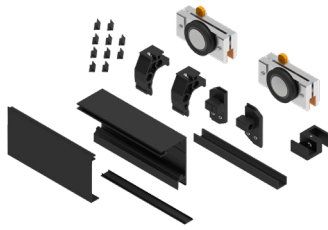

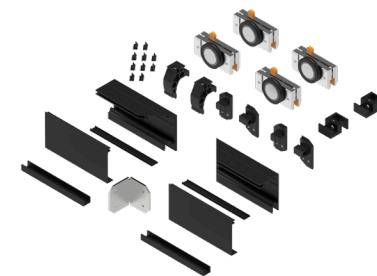

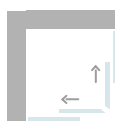

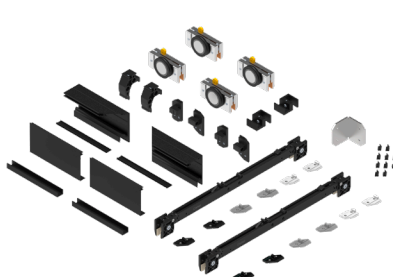

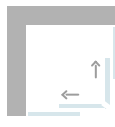

## Componentes

Components | Composants

KITS   KITS   KITS	Acabado	Cód.		
 <p>Kit <b>SV-X50</b>. x2 Freno retenedor SV-X50 kit. x2 Retaining stopper Kit SV-X50. x2 Frein de retenue</p> <p><b>50kg</b></p>  <p>RODAMIENTO A BOLAS BALL BEARING ROULEMENT A BILLES</p>	<p><b>BN</b></p> <p><b>PC</b></p> <p><b>SB</b></p> <p><b>BA</b></p>	<p>0 950 34</p> <p>0 950 35</p> <p>0 950 36</p> <p>0 950 37</p>	2,13m	1 kit 1 jeu
 <p>Kit <b>SV-X50 angular 90°</b>. x2 Freno retenedor SV-X50 kit angular 90°. x2 Retaining stopper Kit SV-X50 angulaire 90°. x2 Frein de retenue</p> <p><b>30kg</b></p>  <p>RODAMIENTO A BOLAS BALL BEARING ROULEMENT A BILLES</p>  <p>*Perfileria cortada a 45°   Profiles cut at 45°   Profils coupés à 45°</p>	<p><b>BN</b></p> <p><b>PC</b></p> <p><b>SB</b></p> <p><b>BA</b></p>	<p>0 950 38</p> <p>0 950 39</p> <p>0 950 40</p> <p>0 950 41</p>	1,5m x2	1 kit 1 jeu
 <p>Kit <b>SV-X50</b>. x1 SofTop doble SV-X50 kit. x1 Double SofTop Kit SV-X50. x1 SofTop double</p> <p><b>50kg</b></p>  <p>RODAMIENTO A BOLAS BALL BEARING ROULEMENT A BILLES</p>	<p><b>BN</b></p> <p><b>PC</b></p> <p><b>SB</b></p> <p><b>BA</b></p>	<p>0 950 20</p> <p>0 950 21</p> <p>0 950 22</p> <p>0 950 23</p>	2,13m	1 kit 1 jeu
 <p>Kit <b>SV-X50 angular 90°</b>. x1 SofTop doble SV-X50 kit angular 90°. x1 Double SofTop Kit SV-X50 angulaire 90°. x1 SofTop double</p> <p><b>30kg</b></p>  <p>RODAMIENTO A BOLAS BALL BEARING ROULEMENT A BILLES</p>  <p>*Perfileria cortada a 45°   Profiles cut at 45°   Profils coupés à 45°</p>	<p><b>BN</b></p> <p><b>PC</b></p> <p><b>SB</b></p> <p><b>BA</b></p>	<p>0 950 42</p> <p>0 950 43</p> <p>0 950 44</p> <p>0 950 45</p>	1,5m x2	1 kit 1 jeu

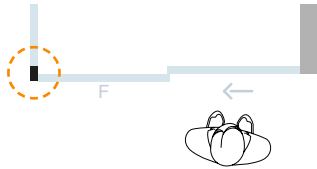
## Componentes

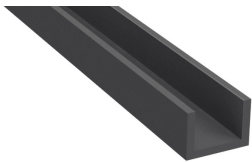
Components | Composants

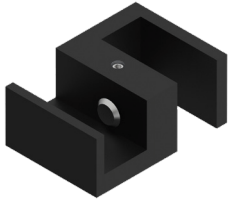
ACCESORIOS   ACCESSORIES   ACCESSOIRES		Acabado	Cód.	المساحة	
	<p>SofTop doble <b>SV-X50</b>                      SV-X50 Double SofTop                      SofTop double SV-X50</p> <p><b>50kg</b></p>		0 950 32		1 pieza 1 piece 1 pièce
	<p>Soporte flotante vidrio fijo 90°. <b>Izquierdo</b>                      Fixed glass mounting bracket 90°. Left                      Support de montage sur verre fixe 90°. Gauche</p> 	<p><b>BN</b></p> <p><b>PC</b></p> <p><b>SB</b></p> <p><b>BA</b></p>	<p>0 950 24</p> <p>0 950 25</p> <p>0 950 26</p> <p>0 950 27</p>		1 pieza 1 piece 1 pièce
	<p>Soporte flotante vidrio fijo 90°. <b>Derecho</b>                      Fixed glass mounting bracket 90°. Right                      Support de montage sur verre fixe 90°. Droit</p> 	<p><b>BN</b></p> <p><b>PC</b></p> <p><b>SB</b></p> <p><b>BA</b></p>	<p>0 950 28</p> <p>0 950 29</p> <p>0 950 30</p> <p>0 950 31</p>		1 pieza 1 piece 1 pièce
	<p>Perfil inferior para vidrio fijo de 8-10mm                      Bottom track for fixed glass of 8-10mm                      Rail inférieur pour verre fixe 8-10mm</p>  <p>17x12mm</p>	<p><b>BN</b></p> <p><b>PC</b></p> <p><b>SB</b></p> <p><b>BA</b></p>	<p>0 971 15</p> <p>0 971 16</p> <p>0 971 17</p> <p>0 971 18</p>	1,5m	1 perfil 1 profile 1 profil
	<p>Guiador inferior flotante SV-X50. Vidrio 8.10mm                      Floating Bottom Guide SV-X50. Glass 8-10mm                      Guide inférieur flottant SV-X50. Verre 8-10 mm</p>	<p><b>BN</b></p> <p><b>PC</b></p> <p><b>SB</b></p> <p><b>BL</b></p>	<p>0 950 49</p> <p>0 950 50</p> <p>0 950 51</p> <p>0 950 52</p>		25 piezas 25 pieces 25 pièces

**BN**

Aluminio Inox repulido  
 Brushed nickel aluminium  
 Aluminium polie nickel  
 Brillante | Shiny | Brillant

**PC**

Aluminio pulido cromado  
 Polished chrome aluminium  
 Aluminium polie chromé  
 Brillante | Shiny | Brillant

**SB**

Aluminio dorado cepillado  
 Satin brass aluminium  
 Aluminium doré brossé  
 Brillante | Shiny | Brillant

**BA**

Aluminio anodizado negro mate  
 Matt black anodized aluminium  
 Aluminium anodisé noir mat

**BL**

Aluminio lacado negro  
 Black lacquered aluminium  
 Aluminium anodisé laqué noir











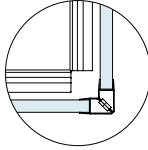

Componentes

Components | Composants

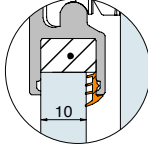
ACCESORIOS   ACCESSORIES   ACCESSOIRES		Acabado	Cód.	متر	📦
	<p>Viereteaguas <b>SV-X50</b> SV-X50 Railing mount Eau gouttière SV-X50</p>  <p>14x25mm</p> 		0 950 46	2m	1 pieza 1 piece 1 pièce
	<p>Perfil plástico salvacantos corredera <b>SV-X50</b> Edge water seal profile sliding door SV-X50 Profilé plastique de finition coulissant SV-X50</p>  <p>14x10mm</p>		00 86 30	3m	2 piezas 2 pieces 2 pièces
	<p>Salvacantos de cierre vidrio-pared <b>SV-X50</b> Edge water seal for closing glass-to-wall SV-X50 Profilé de finition de fermeture verre-mur SV-X50</p>  <p>13x15mm</p> <p>*Se suministra con cinta adhesiva de doble cara   Served with double-sided adhesive tape   Est servi avec du ruban adhésif double face</p> 		0 950 48	2,13m	1 pieza 1 piece 1 pièce
	<p>Salvacantos entre vidrios <b>SV-X50</b> Between glasses water seal SV-X50 Profilé de finition entre les vitres SV-X50</p>  <p>8x20mm</p> <p>*Solo para 8mm de grosor de vidrio   Only for 8mm thick glass   Uniquement pour verre de 8 mm d'épaisseur</p> 		0 950 33	3m	1 pieza 1 piece 1 pièce

**Componentes**

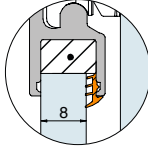
Components | Composants

ACCESORIOS   ACCESSORIES   ACCESSOIRES			Acabado	Cód.	المساحة	
	<p>Juego salvacantos 90/180° imantado <b>SV-X50</b>                      Edge water seal set magnetized for 90/180° SV-X50                      Jeu de profilés de finition magnétiques 90/180° SV-X50</p>  21x10mm			0 950 47	2,2m x2	1 pieza 1 pièce 1 pièce
	<p>Junta transparente PVC 2mm                      PVC profile gasket 2mm                      Joint d'adaptation PVC 2mm</p>  6x3mm		<p> PVCT</p> <p> PVCB</p>	<p>00 45 82</p> <p>00 45 83</p>	1m	1 pieza 1 pièce 1 pièce
	<p>Junta transparente PVC 4mm                      PVC profile gasket 4mm                      Joint d'adaptation PVC 4mm</p>  9x5mm		<p> PVCT</p> <p> PVCB</p>	<p>00 45 84</p> <p>00 45 85</p>	1m	1 pieza 1 pièce 1 pièce



**IESI SOFTOP DOBLE:** gracias a la **nueva tecnología de amortiguación** recientemente desarrollada, el **esfuerzo de apertura** será mínimo, ya que **se reduce hasta casi un 40%**. Asimismo, ofrece un frenado suave y silencioso en los últimos 7cm del recorrido de cierre. Para instalaciones con solo un mínimo de ancho puerta necesario de 630mm. **IENI DOUBLE SOFTOP:** thanks to the **latest developed damping technology**, the **opening effort** is minimal as **it has been reduced by almost 40%**. Likewise, a smooth and silent closing in the last 7cm of the sliding path is achieved. The double SofTop damping system protects the system from impact damage, thus extending the useful life of the product and with only a minimum door width of 630mm required. **IFRI SOFTOP DOBLE :** grâce à la **nouvelle technologie d'amortissement** récemment mise au point, **l'effort d'ouverture** est minimum et **réduit de près de 40%**. Il offre également un freinage en douceur et silencieux dans les 7 derniers centimètres du parcours de fermeture. Pour les installations où seule une largeur de porte minimale de 630mm est requise.

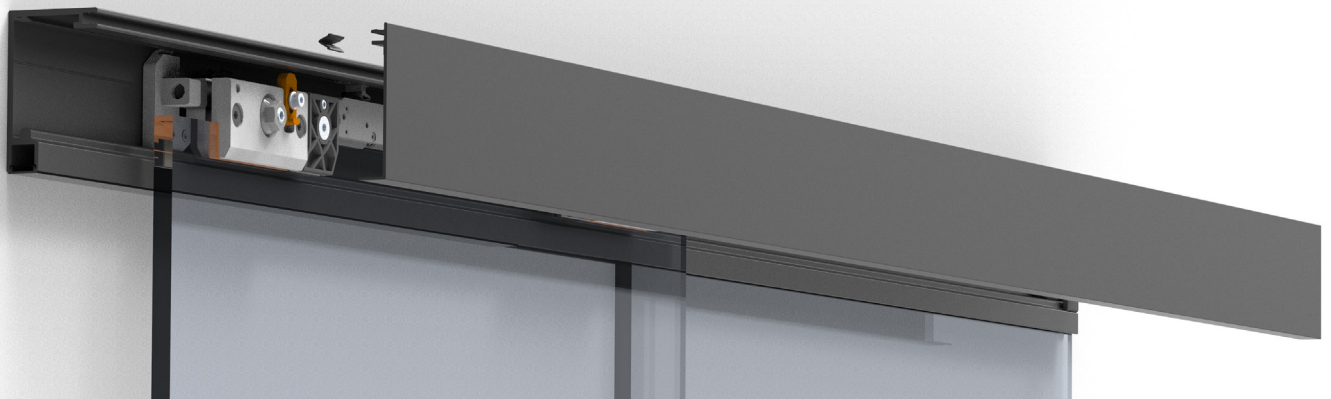



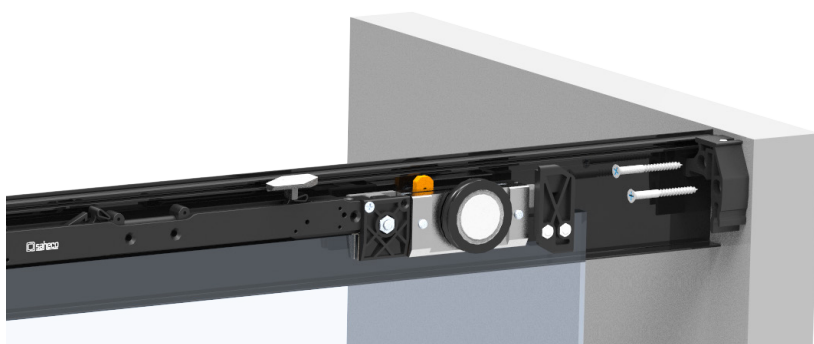







**IESI Acceso frontal a todas las regulaciones y componentes.** Tapeta con clipaje de apriete para ahorro de tiempo de instalación.  
**IENI Frontal access to all components and its adjustments and regulations.** The lateral top cover track is clipped to save installation time.  
**IFRI Accès frontal à tous les réglages et composants.** Bandeau de serrage à clipser pour une installation rapide.

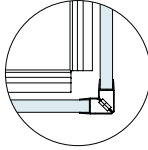

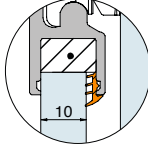
**IESI Soportes flotantes** a pared y vidrio ocultos. **IENI Hidden floating** wall and glass mounting **brackets.** **IFRI Supports muraux flottants** et verre dissimulé.

**Componentes**

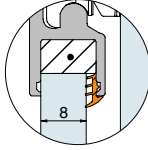
Components | Composants

ACCESORIOS   ACCESSORIES   ACCESSOIRES			Acabado	Cód.	المساحة	
	<p>Juego salvacantos 90/180° imantado <b>SV-X50</b>                      Edge water seal set magnetized for 90/180° SV-X50                      Jeu de profilés de finition magnétiques 90/180° SV-X50</p>  21x10mm			0 950 47	2,2m x2	1 pieza 1 pièce 1 pièce
	<p>Junta transparente PVC 2mm                      PVC profile gasket 2mm                      Joint d'adaptation PVC 2mm</p>  6x3mm		 	00 45 82 00 45 83	1m	1 pieza 1 pièce 1 pièce
	<p>Junta transparente PVC 4mm                      PVC profile gasket 4mm                      Joint d'adaptation PVC 4mm</p>  9x5mm		 	00 45 84 00 45 85	1m	1 pieza 1 pièce 1 pièce



 saheco

## Guibli Glass

SV-GUIBLI SFERA | SV-GUIBLI CUADRO

# GUIBLI GLASS

BIBLIOTECA  
DE DESCARGAS



DOWNLOADS LIBRARY |  
BIBLIOTHÈQUE  
TÉLÉCHARGEMENTS

— ES

## NUEVAS SOLUCIONES SAHECO DE PUERTAS CORREDERAS DE CRISTAL PARA INSTALACIONES DE DUCHAS EN BAÑOS:

Estos sistemas integran diseño y funcionalidad en un mismo espacio y apuesta por el minimalismo como máxima expresión de sus formas. Con dos vertientes, Guibli Sfera y GuibliCuadro, ambos sistemas ofrecen herrajes de acero inoxidable visibles, jugando con líneas esféricas y cuadradas tal y como sus propios nombres indican.

Sus distintas opciones en forma de kit permiten equipar nuestros baños de una forma cómoda y práctica, además de permitir una gran versatilidad de instalaciones: entre paredes, entre pared y vidrio, entre vidrios y en ángulo.

Asimismo, son capaces de soportar hasta 60 Kg por hoja y son aptas para vidrios entre 8 y 10 mm de grosor. Dos soluciones elegantes y perfectas para cualquier propuesta de estilo.

— EN

## SAHECO'S NEW SLIDING GLASS DOOR SOLUTIONS FOR BATH SHOWER INSTALLATIONS:

These systems incorporate design and functionality in the same place and are characterised by the minimalist expression of their forms. With two styles, Guibli Sfera and Guibli Cuadro, both systems offer visible stainless steel metalwork, playing with the spherical and square lines, as their names suggest.

Their different options in kit form make it possible to fit out bathrooms in an easy and practical way while allowing considerable versatility in terms of installation: between walls, between wall and glass pane, between glass panes and on a corner. In addition, they are capable of supporting up to 60Kg per pane and are suitable for glass panes of between 8 and 10 mm thick. Two elegant and perfect solutions for any style proposal.

— FR

## NOUVELLES SOLUTIONS SAHECO DE PORTES COULISSANTES EN VERRE POUR INSTALLATIONS DE DOUCHES EN SALLES DE BAINS :

Alliant design et fonctionnalité dans un même espace, ces systèmes misent sur des formes éminemment minimalistes. Disponibles en deux variantes, Guibli Sfera (Sphère) et Guibli Cuadro (Carré), les deux systèmes offrent des ferrures en acier inoxydable visibles tout en jouant sur les lignes sphériques et carrée comme leur nom l'indique.

Leurs différentes options en forme de kit nous permettent d'équiper la salle de bains en toute commodité et facilité en bénéficiant d'une grande polyvalence d'installation : entre murs, entre mur et verre, entre verres et en angle. De même, ces modèles sont capables de supporter jusqu'à 60 kg par panneau et peuvent être installés avec des verres de 8 à 10 mm d'épaisseur. Deux solutions élégantes et parfaites quel que soit le style désiré.





### Características técnicas

Technical characteristics | Caractéristiques techniques

### Perfilería Profiles | Profils

SFERA

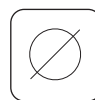

20 mm

CUADRO

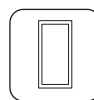

10x30 mm

### Especificaciones Specifications | Spécification

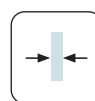

8-10 mm

### Peso Weight | Poids

60 kg

132 lb

### Producto certificado

Certificaded product | Produit certifié





**Variantes de instalación**

Installation possibilities | Variantes d'installation



**Sección tipo**



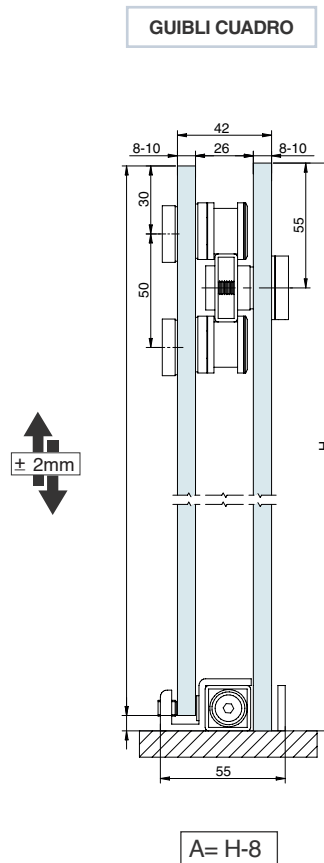
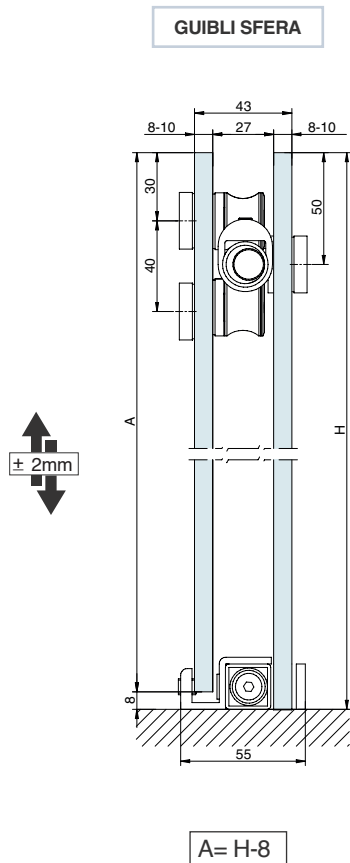







Cros-section | Section type (Cotas en mm | Dimensions in mm | Dimensions en mm)

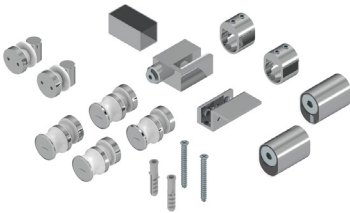

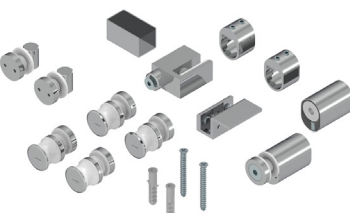

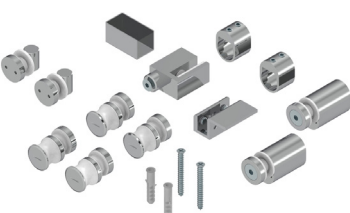
Componentes

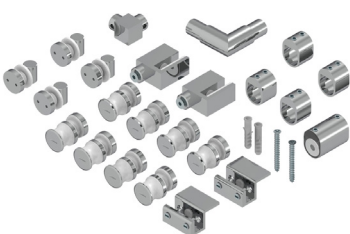
Components | Composants









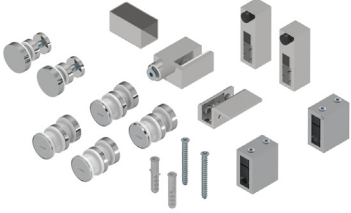

KITS   KITS   KITS	Acabado	Cód.		
 <p><b>Kit SV-Guibli Sfera 1</b> puerta corredera + vidrio fijo entre pared / pared                      SV-Guibli Sfera kit 1 Sliding door + fixed glass between wall / wall                      Kit SV-Guibli Sfera 1 Porte coulissante + verre fixe entre mur / mur</p> <p> SFERA</p>	SSS	00 950 01	Min. 1200/ Max. 1800	1 kit
 <p><b>Kit SV-Guibli Sfera 1</b> puerta corredera + vidrio fijo entre pared / vidrio                      SV-Guibli Sfera kit 1 Sliding door + fixed glass between wall / glass                      Kit SV-Guibli Sfera 1 Porte coulissante + verre fixe entre mur / verre</p> <p> SFERA</p>	SSS	00 950 02	Min. 1200/ Max. 1800	1 kit
 <p><b>Kit SV-Guibli Sfera 1</b> puerta corredera + vidrio fijo entre vidrio / vidrio                      SV-Guibli Sfera kit 1 Sliding door + fixed glass between glass / glass                      Kit SV-Guibli Sfera 1 Porte coulissante + verre fixe entre verre / verre</p> <p> SFERA</p>	SSS	00 950 03	Min. 1200/ Max. 1800	1 kit
 <p><b>Kit SV-Guibli Sfera 2</b> puertas corredera + vidrio fijo en ángulo                      SV-Guibli Sfera kit 2 Sliding doors + fixed glass on a corner                      Kit SV-Guibli Sfera 2 Portes coulissantes + verre fixe en angle</p> <p> SFERA</p>	SSS	00 950 04	800 x 800 / 900 x 900	1 kit

**SSS** Inox brillante  
 Shiny Stainless Steel  
 Inox brillant

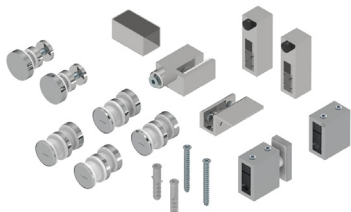

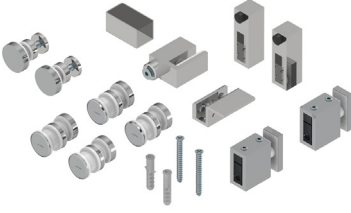
## Componentes

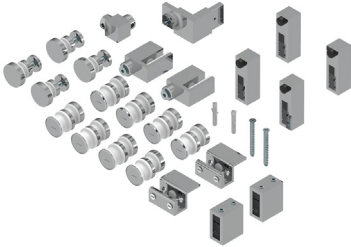
Components | Composants

KITS   KITS   KITS	Acabado	Cód.		
 <p><b>Kit SV-Guibli Cuadro</b> 1 puerta corredera + vidrio fijo entre pared / pared SV-Guibli Cuadro kit 1 Sliding door + fixed glass between wall / wall Kit SV-Guibli Cuadro 1 Porte coulissante + verre fixe entre mur / mur</p> <p> CUADRO</p>	SSS	00 950 11	Min. 1200/ Max. 1800	1 kit
 <p><b>Kit SV-Guibli Cuadro</b> 1 puerta corredera + vidrio fijo entre pared / vidrio SV-Guibli Cuadro kit 1 Sliding door + fixed glass between wall / glass Kit SV-Guibli Cuadro 1 Porte coulissante + verre fixe entre mur / verre</p> <p> CUADRO</p>	SSS	00 950 12	Min. 1200/ Max. 1800	1 kit
 <p><b>Kit SV-Guibli Cuadro</b> 1 puerta corredera + vidrio fijo entre vidrio / vidrio SV-Guibli Cuadro kit 1 Sliding door + fixed glass between glass / glass Kit SV-Guibli Cuadro 1 Porte coulissante + verre fixe entre verre / verre</p> <p> CUADRO</p>	SSS	00 950 13	Min. 1200/ Max. 1800	1 kit
 <p><b>Kit SV-Guibli Cuadro</b> 2 puertas corredera + vidrio fijo en ángulo SV-Guibli Cuadro kit 2 Sliding doors + fixed glass on a corner Kit SV-Guibli Cuadro 2 Portes coulissantes + verre fixe en angle</p> <p> CUADRO</p>	SSS	00 950 14	800 x 800 / 900 x 900	1 kit



# Hydro Glass

SV-HYDRO

# HYDRO GLASS

BIBLIOTECA  
DE DESCARGAS



DOWNLOADS LIBRARY |  
BIBLIOTHÈQUE  
TÉLÉCHARGEMENTS

## ES

Si buscas un diseño contemporáneo y fácil de montar para cabinas de ducha, no te pierdas la solución Hydro Glass.

- Sistema de puerta corredera con rodamiento superior hasta 50Kg por hoja.
- Posibilidad de instalación entre paredes, entre vidrios y entre pared y vidrio.
- Incluye sistema softbrake, para mayor suavidad y seguridad en la apertura y cierre de la instalación.
- Montaje fácil y rápido (pensado para instalaciones con enfoque repetitivo) gracias al diseño de sus embellecedores, pensados para tapar los ajustes de la instalación.
- Acabados para todos los gustos: aluminio anodizado plata mate, aluminio lacado blanco, aluminio lacado negro mate, aluminio pulido cromado.

## EN

If you are looking for a contemporary and easy to install shower enclosure design, don't miss out on the Hydro Glass solution.

- Sliding door system with upper bearing up to 50kg per leaf.
- Option of installation between walls, between glass and between wall and glass.
- Includes softbrake system, for greater smoothness and safety while opening and closing the installation.
- Easy and quick assembly (designed for installations with repetitive focus) thanks to the design of its trims, created to hide the installation adjustments.
- Finishes to suit all tastes: matt silver anodised aluminium, white lacquered aluminium, matt black lacquered aluminium, chromed polished aluminium.

## FR

Si vous êtes à la recherche d'une paroi de douche contemporaine et facile à installer, ne manquez pas la solution Hydro Glass.

- Système de porte coulissante avec palier supérieur jusqu'à 50 kg par vantail.
- Possibilité d'installation entre les murs, entre des vitres et entre le mur et le verre.
- Comprend un système de frein souple, pour une ouverture et une fermeture de l'installation en douceur et sécurisée.
- Montage facile et rapide (conçu pour les installations à usage répétitif) grâce à la conception de ses garnitures, destinées à couvrir les réglages de l'installation.
- Des finitions pour tous les goûts : aluminium anodisé argent mat, aluminium laqué blanc, aluminium laqué noir mat, aluminium poli chromé.





### Características técnicas

Technical characteristics | Caractéristiques techniques

#### Perfilería Profiles | Profils



42,5x54,6mm



17x12mm

#### Especificaciones Specifications | Spécification

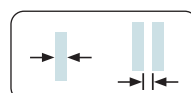

8 mm 22 mm



2 SOFTBRAKE  
MIN. 620 mm



RODAMIENTO A BOLAS  
BALL BEARING  
ROULEMENT À BILLES



SOFTBRAKE  
MÁX.50Kg

#### Peso Weight | Poids

50 kg

110 lb

### Producto certificado

Certificated product | Produit certifié

- Durabilidad | Durability | Durabilité  
Gade 6 = 100.000 ciclos de ensayo | test cycles | cycles de test
- Resistencia a la corrosión | Corrosion resistance | Résistance à la corrosion  
Gade 3 = 96h



### Variantes de instalación

Installation possibilities | Variantes d'installation

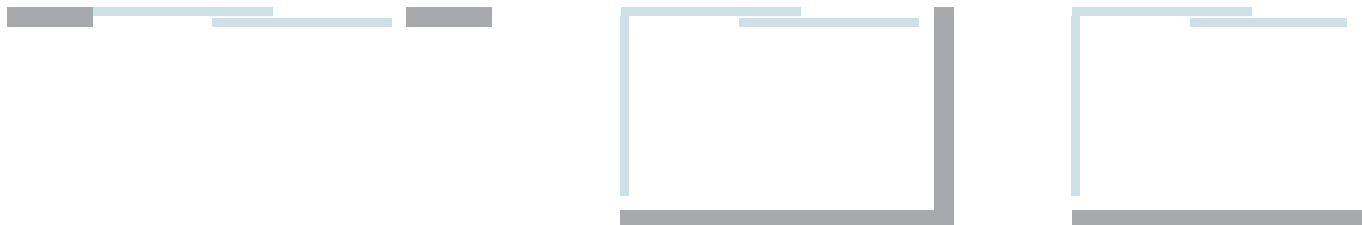

Para instalaciones superiores a 2 metros con 2 vidrios fijos y 1 corredero, o 2 vidrios fijos y 2 correderos, consultar con nuestro departamento comercial.  
For large installations over 2 meters, with 2 fixed glasses panels 1 sliding or 2 fixed glasses panels 2 sliding panels, please contact our sales department.  
Pour des installations de plus 2 mètres de longueur, avec 2 verres fixes et 1 coulissante ou 2 verres fixes et 2 coulissantes, s'il vous plaît de contacter notre département des ventes.

### Sección tipo

Cros-section | Section type (Cotas en mm | Dimensions in mm | Dimensions en mm)

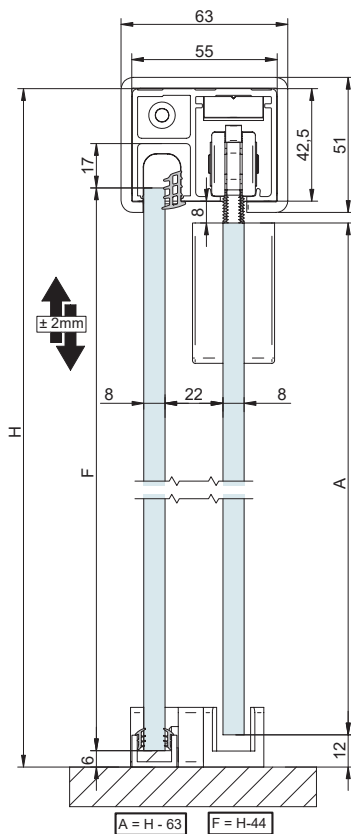





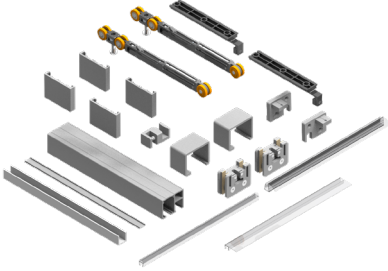

Componentes

Components | Composants

PERFILERÍA   PROFILES   PROFILS		Acabado	Cód.		
 <p>Perfil inferior para vidrio fijo de 8-10-12mm Bottom track for fixed glass of 8-10-12mm Rail inférieur pour verre fixe 8-10-12mm</p>  <p>17x12mm</p>		00 87 24	2 m	1 perfil 1 profile 1 profil	
		00 87 34	3 m		
		00 87 64	6 m		
		00 71 96	2 m		
		00 71 91	3 m		
		00 71 97	6 m		
		00 71 86	2 m		
		00 71 81 00 71 87	3 m 6 m		

KITS   KITS   KITS		Acabado	Cód.		
 <p>Kit <b>SV-Hydro</b> Doble Softbrake Instalación entre paredes SV-Hydro kit with double Softbrake Wall-to-wall mounting SV-Hydro avec 2 amortisseurs Fixation mur à mur</p>  <p>43x55mm</p>  <p>RODAMIENTO A BOLAS BALL BEARING ROULEMENT À BILLES</p>		0 978 10	1,5m	1 kit	
		0 978 20	2 m		
		0 978 11	1,5m		
		0 978 21	2 m		
		0 978 12 0 978 22	1,5m 2 m		
			0 978 13 0 978 23		1,5m 2 m

 <p>Kit <b>SV-Hydro</b> Doble Softbrake Instalación entre vidrios / entre pared y vidrio SV-Hydro kit with double Softbrake Glass-to-glass / wall-to-glass mounting SV-Hydro avec 2 amortisseurs Fixation verre à verre / mur à verre</p>  <p>43x55mm</p>  <p>RODAMIENTO A BOLAS BALL BEARING ROULEMENT À BILLES</p>		0 978 14	1,5m	1 kit
		0 978 24	2 m	
		0 978 15	1,5m	
		0 978 25	2 m	
		0 978 16 0 978 26	1,5m 2 m	
			0 978 17 0 978 27	

ACCESORIOS   ACCESSORIES   ACCESSOIRES		Acabado	Cód.		
 <p>Junta transparente PVC 3mm PVC profile gasket 3mm Joint d'adaptation PVC 3mm</p>		00 45 87	1m	1 pieza 1 piece 1 pièce	

Aluminio anodizado plata mate  
Satin anodized aluminium  
Aluminium anodisé argent

Aluminio lacado blanco brillo  
White lacquered aluminium  
Aluminium anodisé laqué blanc

Aluminio lacado negro mate  
Black lacquered aluminium  
Aluminium anodisé laqué noir

Aluminio pulido cromado  
Chrome polished aluminium  
Aluminium polie chromé  
Brillante | Shiny | Brillant



 saheco

## Room Glass

SV-IT10

# ROOM GLASS

BIBLIOTECA  
DE DESCARGAS



DOWNLOADS LIBRARY |  
BIBLIOTHÈQUE  
TÉLÉCHARGEMENTS

## ES

### **DIVISIONES DE CRISTAL PARA OFICINAS: OPTIMIZA Y DIVIDE ESPACIOS SIN NECESIDAD DE REALIZAR OBRAS.**

**1.** Perfilera de aluminio anodizado plata para mamparas divisorias de vidrio. **2.** Rapidez de montaje y respuesta acústica. **3.** Adaptación a todo tipo de espacios gracias a su amplia gama de variantes de instalación: perfil superior visto o a falso techo, posibilidad de combinar vidrio y madera, variantes de 90° y 135°, entre muchas otras. **4.** Posibilidad de incorporar tecnología LED como elemento decorativo, señalización o para evitar que se vea el espacio interior.

## EN

### **GLASS PARTITIONS TO OPTIMISE AND DIVIDE SPACES WITHOUT CONSTRUCTION WORK.**

**1.** Satin anodised aluminium tracks. **2.** Fast assembly and acoustic performance. **3.** Suitable for any architectural space thanks to its wide range of configurations: top profile can be exposed or hidden in the false ceiling, possibility to combine wood and glass, 90° and 135° variants, and many more. **4.** Optional built-in LED system to add decorative value, signage, or even to provide privacy to the inside of the room.

## FR

### **DES CLOISONS EN VERRE POUR LES BUREAUX : OPTIMISE ET DIVISE LES ESPACES SANS NÉCESSITER DE TRAVAUX DE CONSTRUCTION.**

**1.** Profilés en aluminium anodisé argent pour les cloisons en verre. **2.** Montage rapide et réponse acoustique. **3.** Adaptabilité à tous les types d'espaces grâce à son large éventail de variantes d'installation : profil supérieur apparent ou faux plafond, possibilité de combiner le verre et le bois, variantes à 90° et 135°, entre autres. **4.** Possibilité d'intégrer la technologie LD comme élément de décoration, de signalisation ou pour empêcher de voir l'espace intérieur.





### Características técnicas

Technical characteristics | Caractéristiques techniques

### Perfilería Profiles | Profils

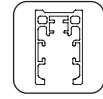

27x42 mm

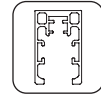

27x42 mm

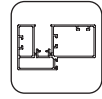

79x46 mm

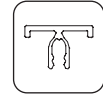

20 mm

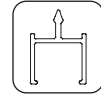

21x19 mm

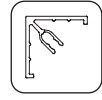

26x26 mm

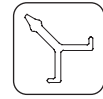

4x4 mm

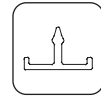

20 mm

### Especificaciones Specifications | Spécification

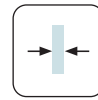

10-12 mm

### Producto certificado

Certificatèd product | Produit certifié





## Variantes de instalación

Installation possibilities | Variantes d'installation

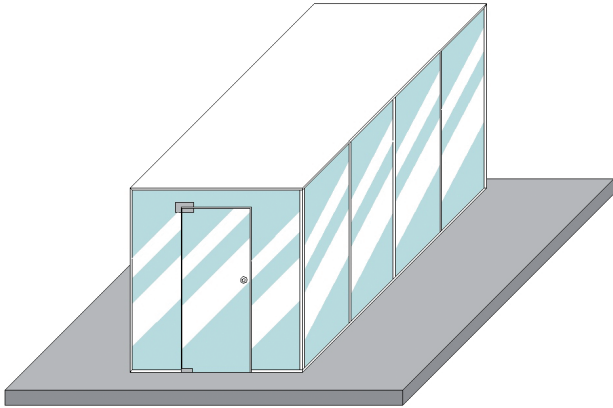

Instalación del perfil superior visto u oculto en el falso techo | Installing the top profile revealed or hidden in a false ceiling | Installation du profil supérieur visible ou dissimulé dans le faux plafond.

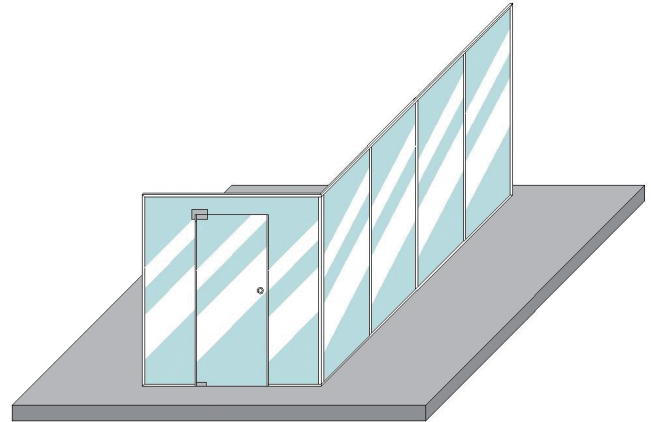

Divisiones hasta media altura con embellecedor superior y fijadas a la pared con limitaciones por cuestiones de seguridad | Dividers up to half height with top trim, and secured to the wall with limitations for safety reasons | Divisions à mi-hauteur avec enjoliveur supérieur, fixées au mur avec des limitations pour motifs de sécurité.

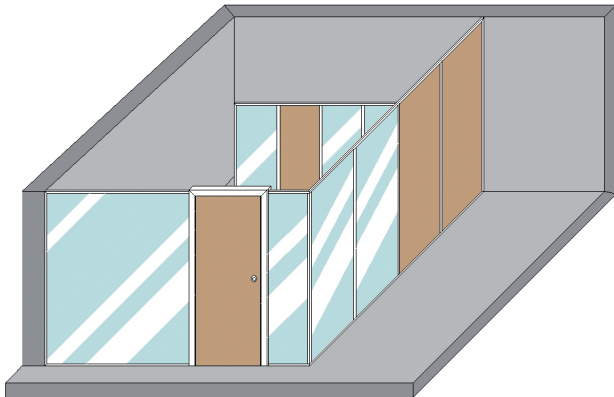

Divisiones en material combinado cristal/madera con perfilera IT-10. | Dividers in combined material Glass/wood, with IT-10 profiles. | Divisions en matériau combiné verre/bois avec profil IT-10.

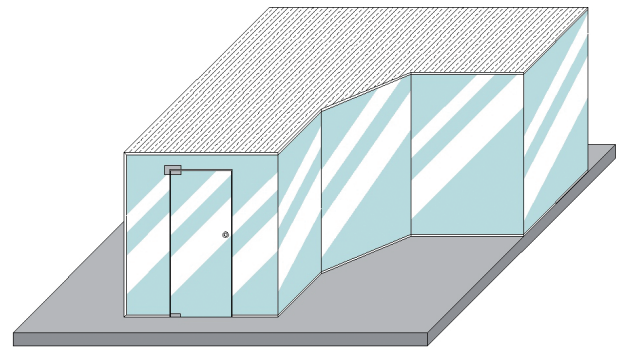

Divisiones con variantes de 90° y 135° | Dividers with 90° and 135° variants. | Divisions à variantes de 90 ° et 135 °.



## Variantes de instalación

Installation possibilities | Variantes d'installation

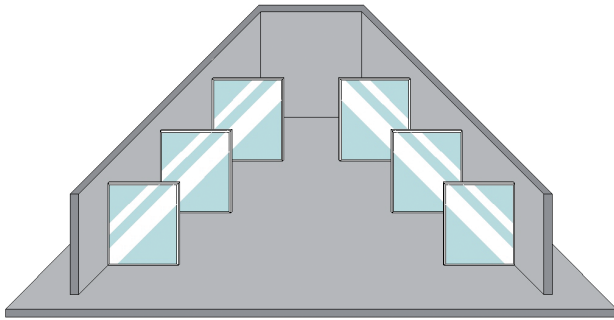

Paneles divisorios de cristal fijo de media altura o hasta el techo | Fixed glass dividing panels – half height or up to the ceiling | Panneaux séparateurs en verre fixe à mi-hauteur ou jusqu'au plafond.

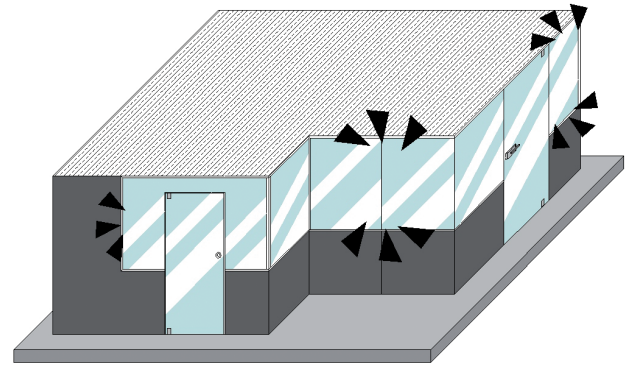

Instalación sobremuro en combinación de 90° y la posibilidad de instalar led's | On-wall fitting in 90° combination, with the possibility of fitting LEDs | Installation en surface combinée de 90° avec possibilité d'installer des LED.

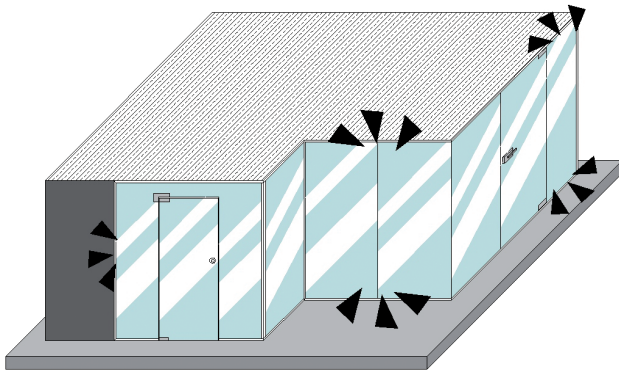

Instalación en combinación de 90° con dos puertas batientes, una directo al techo y la otra con tarjeta de cristal fijo y opción de led's | Installation in 90° combination with two hinged doors, one direct to the ceiling and another with fixed glass card and option of fitting LEDs | Installation combinée de 90° avec deux portes battantes, une directement au plafond et l'autre avec carte en verre fixe et option de LED.

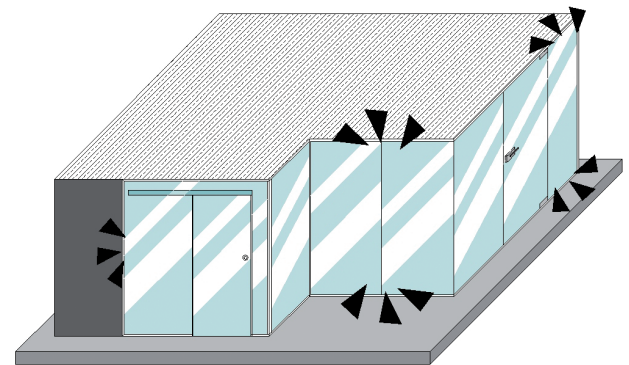

Instalación en combinación de perfiles IT-10, con puertas correderas y la posibilidad de instalar led's | Installation in combinations of IT-10 profiles, with sliding doors and the possibility of installing LEDs | Installation combinée de profil IT-10, avec portes coulissantes et possibilité d'installer des LED.



 Cristal  
Glass  
10-12mm Verre

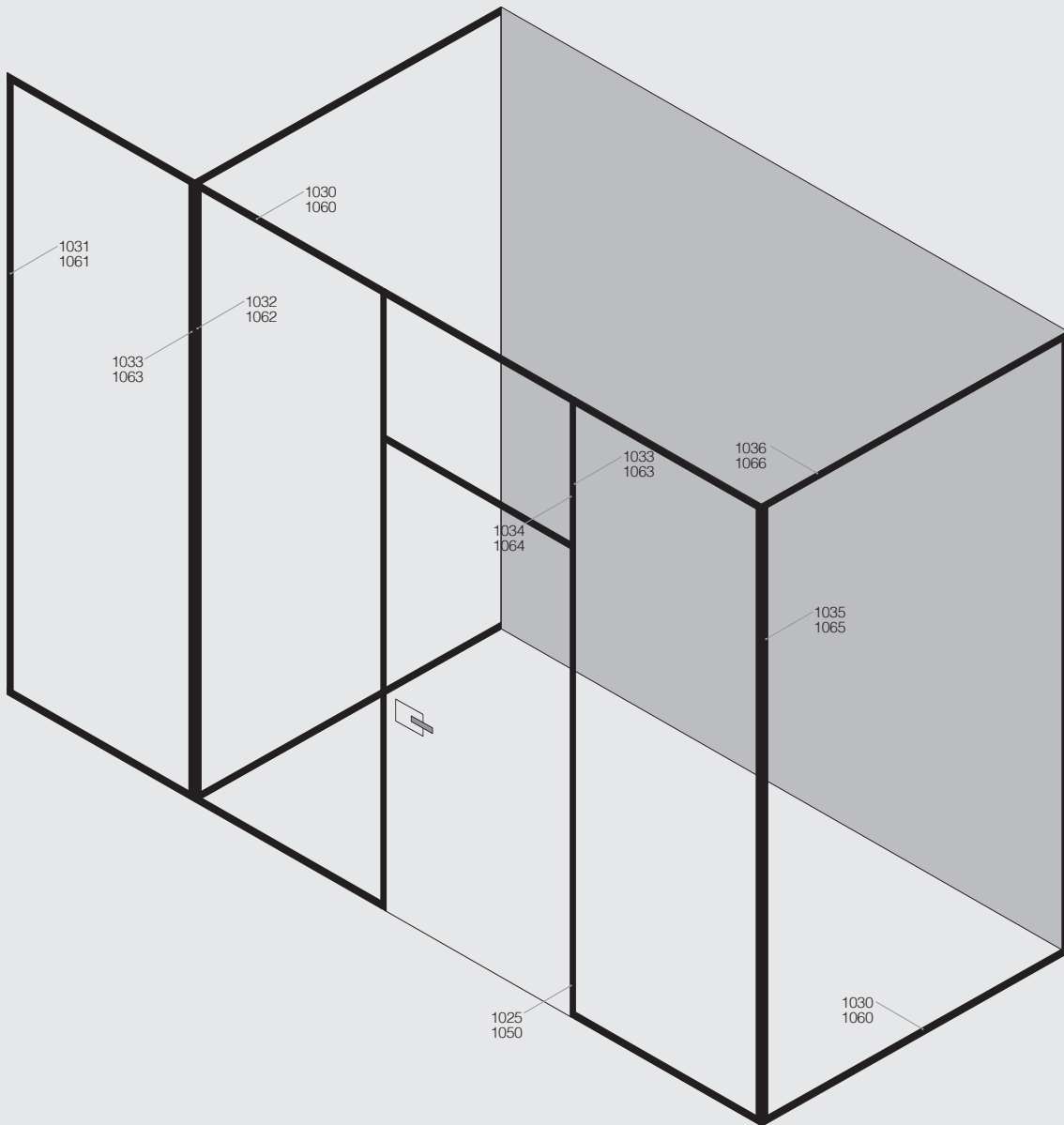

## Componentes

### Components | Composants

PERFILERÍA   PROFILES   PROFILS		Acabado	Cód.		
	<p>Perfil para techo, suelo y pared Track for ceiling, floor and wall Rail pour plafond, sol et mur</p>  27x42mm		00 10 30' 00 10 60'	3 m 6 m	2 perfiles 2 profiles 2 profils
	<p>Perfil embellecedor final Final trim track Capuchon final rail</p>  27x42mm		00 10 31' 00 10 61'	3 m 6 m	2 perfiles 2 profiles 2 profils
	<p>Perfil macho unión en "T" T-shaped male connecting track Rail mâle de raccord en «T»</p>  21x19mm		00 10 32 00 10 62	3 m 6 m	2 perfiles 2 profiles 2 profils
	<p>Perfil hembra unión en "T" y continua T-shaped and continuous female connecting track Rail femelle de raccord en «T» et continu</p>  20mm		00 10 33 00 10 63	3 m 6 m	2 perfiles 2 profiles 2 profils
	<p>Perfil macho unión continua Continuous male connecting track Rail mâle de raccord continu</p>  20mm		00 10 34 00 10 64	3 m 6 m	2 perfiles 2 profiles 2 profils
	<p>Perfil hembra unión en "L" L-shaped female connecting track Rail femelle de raccord en «L»</p>  26x26mm		00 10 35 00 10 65	3 m 6 m	2 perfiles 2 profiles 2 profils
	<p>Perfil macho unión en "L" L-shaped male connecting track Rail mâle de raccord en «L»</p>  4x4mm		00 10 36 00 10 66	3 m 6 m	2 perfiles 2 profiles 2 profils
	<p>Perfil marco para puerta de madera y cristal Frame track for wooden and glass door Rail de cadre pour porte en bois et verre</p>  79x46mm		00 10 25' 00 10 50'	3 m 6 m	1 perfil 1 profile 1 profil

<sup>1</sup>Perfiles que se permite instalar una tira de Leds | <sup>1</sup>Profiles that allow a strip of LEDs to be fitted |  
<sup>1</sup>Profils qui permettent l'installation d'un bandeau à LED



## Componentes

### Components | Composants

ACCESORIOS   ACCESSORIES   ACCESSOIRES		Acabado	Cód.		
	<p>Centrador recto 180° para perfil Straight 180° centring element for track Centreur droit 180° pour rail</p>	GI	00 10 71	50x10x2	10 piezas 10 pièces 10 pièces
	<p>Centrador escuadra 90° para perfil Square 90° centring element for track Centreur équerre 90° pour rail</p>	GI	00 10 79	50x10x2 (x2)	10 piezas 10 pièces 10 pièces
	<p>Centrador escuadra 90° vertical para perfil Vertical square 90° centring element for track Centreur équerre 90° vertical pour rail</p>	GI	00 10 73	50x10x2 (x2)	10 piezas 10 pièces 10 pièces
	<p>Corcho para perfil superior e inferior Cork for top and bottom track Liège pour rail supérieur et inférieur</p>		00 10 78	15,5mm	44m
	<p>Corcho para perfiles unión Cork for joint track Liège pour rails de raccord</p>		00 10 80	5,75mm	33m
	<p>Grueso madera (no leds) Thickness of wood (no LEDs) Épaisseur bois (sans LED)</p>		00 10 26	2m	1 pieza 1 pièce 1 pièce

GI

Hierro cincado  
Galvanized iron  
Fer zingué

## Componentes

### Components | Composants

ACCESORIOS   ACCESSORIES   ACCESSOIRES		Acabado	Cód.	المتر	
	Grueso metacrilato (leds) Thickness of Perspex (LEDs) Épaisseur méthacrylate (LED)		00 10 27	2m	1 pieza 1 piece 1 pièce
	Junta goma fijación Rubber securing seal Joint de fixation en caoutchouc	BP	00 10 00 (10mm) 00 10 01 (12mm)	1 m	1 pieza 1 piece 1 pièce
		PG	00 10 10 (10mm) 00 10 11 (12mm)	1 m	
	Junta goma tope perfil marco puerta Door frame track rubber stop seal Joint en caoutchouc butée du rail sur encadrement porte	BP	00 10 12	1 m	1 pieza 1 piece 1 pièce
	Tira de leds para perfil Strip of leds for track Bandeau à leds pour rail		00 10 74	5 m	1 pieza 1 piece 1 pièce
	Transformador para una tira leds de 5 m Transformer for a 5 metre strip of LEDs Transformateur pour bandeau à LED de 5 m		00 10 75	12v	1 pieza 1 piece 1 pièce
	Juego tapa plástico para perfil Plastic cover set for track Jeu de cache plastique pour rail	PPS	00 10 76	26x42	10 piezas 10 pieces 10 pièces



## Componentes

Components | Composants

ACCESORIOS   ACCESSORIES   ACCESSOIRES		Acabado	Cód.		
	<p>Junta acrílica unión continua            Continuous acrylic joining seal            Joint acrylique de raccord continu</p>	P	00 10 13 (10mm) 00 10 14 (12mm)	3 m	1 pieza 1 piece 1 pièce
	<p>Junta acrílica unión en "L"            L-shaped acrylic joining seal            Joint acrylique de raccord en «L»</p>	P	00 10 15 (10mm) 00 10 16 (12mm)	3 m	1 pieza 1 piece 1 pièce
	<p>Junta acrílica unión en "T"            T-shaped acrylic joining seal            Joint acrylique de raccord en «T»</p>	P	00 10 17 (10mm) 00 10 18 (12mm)	3 m	1 pieza 1 piece 1 pièce
	<p>Junta acrílica unión para 135° (vidrio 10-12mm)            Acrylic joining seal for 135° (10-12mm glass)            Joint acrylique de raccord pour 135° (verre 10-12mm)</p>	P	00 10 19 (10mm) 00 10 20 (12mm)	3 m	1 pieza 1 piece 1 pièce



## **Eco Glass**

SV-E40 | SV-E75

# ECO GLASS

BIBLIOTECA  
DE DESCARGAS



DOWNLOADS LIBRARY |  
BIBLIOTHÈQUE  
TÉLÉCHARGEMENTS

## ES

SV-E40 / SV-E75 es un sistema de puertas correderas de cristal suspendidas, sin marco y de alta calidad. Ideal para divisiones y puertas de uso doméstico o comercial de peso ligero o medio.

Solución para hojas de 40 y 75 Kg respectivamente. Perfil superior de aluminio diseñado con estrías laterales que permiten fijar y extraer fácilmente las tapetas embellecedoras. Esta solución funciona con rodamiento con cojinetes a bolas que permiten absorber la falta de paralelismo de la instalación. También cuenta con guiador inferior ajustable a los diferentes grosores de vidrio con o sin cepillo, el último de los cuales proporciona una reducción del sonido en la acción de apertura y cierre de la hoja. **NO SE REQUIERE MECANIZACIÓN DEL VIDRIO.**

## EN

The SV-E40 / SV-E75 are high quality sliding systems for frameless glass sliding doors that also give excellent value for money. Ideal for light to medium weight doors in domestic or commercial applications.

Capable of supporting door weights of up to 40Kgs and 75Kgs respectively, the SV-E40 / SV-E75 systems have an aluminium top track which is grooved on the outside to allow the pelmet covers to be easily clipped into place and removed if necessary.

The roller hangers are fitted with sealed ball race bearings to ensure a smooth and quiet sliding action, and the bottom guide channel is available in two versions, with or without an accompanying brush strip, with the former providing a quieter operational solution. Clear threshold bottom guides are also available. **NO DRILLING OF GLASS REQUIRED.**

## FR

Les modèles SV-E40 / SV-E75 sont des systèmes de portes coulissantes en verre suspendues, sans cadre et de grande qualité. Idéales pour les placards, divisions et portes à usage domestique ou commercial de poids léger ou moyen.

Solutions pour panneaux de 40 et 75 kg respectivement. Profil supérieur en aluminium avec stries latérales qui permettent de fixer et d'extraire facilement les enjoliveurs. Ces modèles fonctionnent à l'aide d'un roulement sur coussinets à billes qui permettent d'absorber le manque de parallélisme de l'installation. Ils disposent également d'un guide inférieur réglable selon les différentes épaisseurs de verre avec ou sans brosse. La variante avec brosse amortit les bruits d'ouverture et de fermeture du panneau. **N'EXIGE PAS L'USINAGE DU VERRE.**





### Características técnicas

Technical characteristics | Caractéristiques techniques

#### Perfilería Profiles | Profils



28x27 mm



30x29 mm



20x20 mm



12x17 mm



20x15 mm

#### Especificaciones Specifications | Spécification



8-10 mm

#### Peso Weight | Poids

40 kg	86 lb
75 kg	166 lb

#### Producto certificado

Certificated product | Produit certifié



**Variantes de instalación**

Installation possibilities | Variantes d'installation



**Sección tipo**

Cros-section | Section type (Cotas en mm | Dimensions in mm | Dimensions en mm)

SV-E40

SV-E75

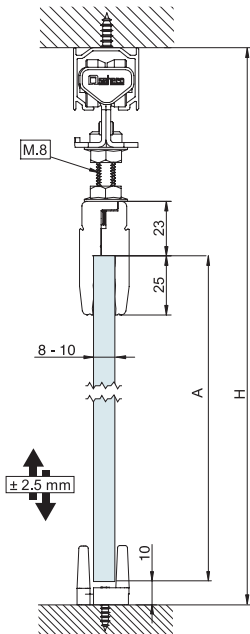

A= H-95

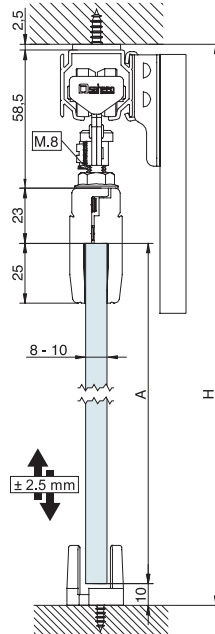

A= H-94

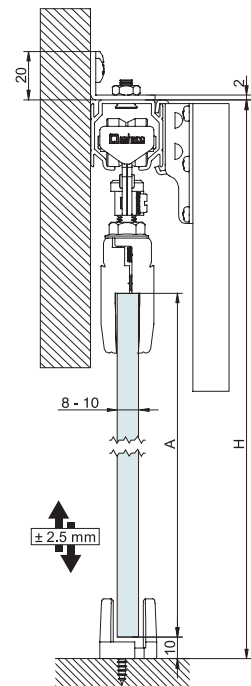

A= H-94



## Componentes

Components | Composants

PERFILERÍA   PROFILES   PROFILS		Acabado	Cód.		
	Perfil superior (solo con SV-E40) Top track (only with SV-E40) Rail supérieur (uniquement avec SV-E40)	MF	00 39 20 00 39 30 00 39 50	2 m 3 m 5 m	6 perfiles 6 profiles 6 profils
	Perfil superior <b>Standard</b> Standard Top track Rail supérieur Standard	S MF	00 60 20 00 60 30 00 60 50 00 61 20 00 61 30 00 61 50	2 m 3 m 5 m 2 m 3 m 5 m	6 perfiles 6 profiles 6 profils
	Perfil inferior para vidrio fijo de 8-10-12mm Bottom track for fixed glass of 8-10-12mm Rail inférieur pour verre fixe 8-10-12mm	S	00 87 15 00 87 30 00 87 60	1,5 m 3 m 6 m	1 perfil 1 profile 1 profil
	Perfil inferior para vidrio fijo de 8-10-12mm Bottom track for fixed glass of 8-10-12mm Rail inférieur pour verre fixe 8-10-12mm	S WL BL	00 87 24 00 87 34 00 87 64 00 71 96 00 71 91 00 71 97 00 71 86 00 71 81 00 71 87	2 m 3 m 6 m 2 m 3 m 6 m 2 m 3 m 6 m	1 perfil 1 profile 1 profil
	Perfil inferior con burlete de 8-10-12mm Bottom track with brush of 8-10-12mm Rail inférieur avec bourrelet de 8-10-12mm	S	00 41 22 00 41 32 00 41 62	2 m 3 m 6 m	1 perfil 1 profile 1 profil
JUEGOS   SETS   JEUX		Acabado	Cód.		
	Juego de accesorios <b>SV-E40</b> SV-E40 Fitting set Garniture SV-E40		00 46 02		1 juego 1 kit 1 jeu

**S** Aluminio anodizado plata mate  
 Satin anodized aluminium  
 Aluminium anodisé argent

**MF** Aluminio natural  
 Mill finish aluminium  
 Aluminium brut

**WL** Aluminio lacado blanco brillo  
 White lacquered aluminium  
 Aluminium anodisé laqué blanc

**BL** Aluminio lacado negro mate  
 Black lacquered aluminium  
 Aluminium anodisé laqué noir



## Componentes

Components | Composants

JUEGOS   SETS   JEUX	Acabado	Cód.		
 <p>Juego accesorios <b>SV-E75</b>  SV-E75 Fitting set  Garniture SV-E75</p> <p><b>75kg</b></p>  <p>RODAMIENTO A BOLAS  BALL BEARING  ROULEMENT À BILLES</p>		00 76 01		1 juego 1 kit 1 jeu
 <p>Juego roldana <b>SV-E40</b>  SV-E40 Roller set  Jeu de galets SV-E40</p> <p><b>40kg</b></p>  <p>RODAMIENTO A BOLAS  BALL BEARING  ROULEMENT À BILLES</p>		00 39 61		5 juegos 5 kits 5 jeux
 <p>Juego roldana <b>SV-E75</b>  SV-E75 Top hangers set  Jeu de galets SV-E75</p> <p><b>75kg</b></p>  <p>RODAMIENTO A BOLAS  BALL BEARING  ROULEMENT À BILLES</p>		00 76 58		5 juegos 5 kits 5 jeux
 <p>Juego de tornillos de ajustes <b>SV-E40</b>  SV-E40 Adjustment screw set  Jeu vis porteuse avec écrou SV-E40</p>		00 46 56		5 juegos 5 kits 5 jeux
 <p>Juego de tornillos de ajustes <b>SV-E75</b>  SV-E75 Adjustment screw set  Jeu vis porteuse avec écrou SV-E75</p>		00 76 56		5 juegos 5 kits 5 jeux
 <p>Freno retenedor <b>SV-E40 / SV-E75</b>  SV-E40 / SV-E75 Retaining stopper  Frein de retenue SV-E40 / SV-E75</p>		00 75 58		25 piezas 25 pieces 25 pièces



Componentes

Components | Composants

ACCESORIOS   ACCESSORIES   ACCESSOIRES		Acabado	Cód.		
	Soporte pared escuadra Wall fixing bracket Support équerre pour fixation à mur		00 60 54 <sup>1</sup>		25 piezas 25 pieces 25 pièces
	Soporte pared escuadra largo Long wall fixing bracket Support équerre pour fixation à mur longue		00 60 59 <sup>1</sup>		25 piezas 25 pieces 25 pièces
	Juego pinza <b>SV-E40</b> regulable <b>SV-1</b> SV-E40 SV-1 Adjustable clamp set Jeu de pince SV-E40 réglable SV-1 		00 40 58		1 juego 1 kit 1 jeu
	Juego pinza <b>SV-E75</b> regulable <b>SV-2</b> SV-E75 SV-2 Adjustable clamp set Jeu de pince SV-E75 réglable SV-2 		00 60 58		1 juego 1 kit 1 jeu
	Guiador inferior plástico para vidrio de 8-12mm Plastic bottom guide for glass of 8-12mm Guide inférieur plastique pour verre de 8-12mm		00 40 57		25 piezas 25 pieces 25 pièces
	Guiador inferior para vidrio de 8-14 mm Bottom guide for glass of 8-14mm Guide inférieur pour verre 8-14mm	<div style="display: flex; flex-direction: column; gap: 5px;"> <div style="background-color: #333; color: white; padding: 2px 5px; display: inline-block;">S</div> <div style="border: 1px solid black; padding: 2px 5px; display: inline-block;">WL</div> <div style="background-color: #333; color: white; padding: 2px 5px; display: inline-block;">BL</div> </div>	0 155 73  00 71 90  00 71 80		1 pieza 1 piece 1 pièce

<sup>1</sup>Para las familias que incorporen soporte pared con perfilera de 2 m, 3 m o 5 m, aplicar uno por cada taladro | <sup>1</sup>For sets that incorporate a wall support with 2m, 3m, 5m or 6m profiling, apply one for each drill hole | <sup>1</sup>Pour les familles intégrant un support mural avec huisserie de 2m, 3m, 5m ou 6m, appliquer un support pour chaque trou percé.

2 m - 10 soportes pared | supports wall | supports muraux 3 m - 15 soportes pared | supports wall | supports muraux 5 m - 25 soportes pared | supports wall | supports muraux



## Essential Glass

SV-A40 | SV-A60 EASY | SV-P70 EASY | SV-A90 | SV-A90 EASY

# ESSENTIAL GLASS

BIBLIOTECA  
DE DESCARGAS



DOWNLOADS LIBRARY |  
BIBLIOTHÈQUE  
TÉLÉCHARGEMENTS

## ES

1. Sistema para puertas correderas de interior de vidrio. 2. **STAR**, una única guía lisa y elegante con distintas opciones de instalación. 3. Instalación a pared, a techo, entre paredes, falso techo o falso techo invisible. 4. Perfilera y accesorios en acabados aluminio anodizado plata mate y lacado negro y blanco mate. 5. Montaje rápido y eficiente: **Perfil Funda FT** (falso techo/entre paredes) para guía extraíble que posibilita la instalación por fases y permite un acceso directo a los herrajes en cualquier momento de la instalación. 6. **Perfil STAR FTI** (Falso Techo Invisible): que queda totalmente oculto en el techo y con posibilidad de **Registro STAR FTI**: pequeño acceso invisible compatible con juegos sin SofTop que permite montar y desmontar los herrajes sin dañar el techo. 7. **Pinza Easy**: minimalista gracias a sus reducidas medidas de fácil instalación gracias a la entrada frontal de la misma. 8. Perfil separador con geometría pensada para ahorrar tiempo en la instalación a pared. 9. **Distintas opciones de rodamiento**: a fricción o a bolas, ambas silenciosas y con un mínimo de esfuerzo de deslizamiento. 10. **Posibilidad de freno amortiguador (SofTop) doble** para SV-P70 Easy y SV-A90 Easy para un cierre suave y sin impactos. 11. Sin necesidad de guía en el suelo para dejar libre la zona de paso. 12. No se requiere mecanización del vidrio en ninguna de las aplicaciones. 13. Certificado Applus+ según la norma EN 1527 para toda la familia. Grado de Durabilidad 6: 100.000 ciclos de ensayo y Grado de Corrosión 3: 96h.

## EN

1. System for interior glass sliding doors. 2. **STAR**, a single smooth and elegant top track with different installation options. 3. Wall or ceiling installation, with exposed profile or false ceiling, or invisible false ceiling. 4. Finishes in matte anodized silver aluminum and matte black and white lacquer. 5. Quick and efficient assembly: **FT Cover profile** (false ceiling and between walls) for a removable guide that allows phased installation and direct access to the hardware at any time during installation. 6. **STAR FTI** (Invisible False Ceiling): fully hidden in the ceiling with the option of **STAR FTI register**: small, invisible access compatible with systems without SofTop, allowing fittings to be mounted and dismantled without damaging the ceiling. 7. **Easy Clamp**, the most minimalistic solution available thanks to its compact cover. 8. Separator wall mounting track designed to optimize and reduce installation time. 9. **Different bearing options**: friction or ball bearings, both silent and requiring minimal sliding. 10. **Possibility of double damping brake (SofTop)** for SV-P70 Easy and SV-A90 Easy for a smooth, impact-free closing. 11. No need for a floor guide, leaving the passage area free of obstacles. 12. No machining of the glass is required for any of the applications. 13. Applus+ quality certification according to EN 1527 standard. Durability Grade 6: 100,000 test cycles, and Corrosion Grade 3: 96h.

## FR

1. Système pour portes coulissantes intérieures en verre. 2. **STAR**, un rail supérieur simple, lisse et élégant avec différentes options d'installation. 3. Installation murale ou au plafond, avec profil visible ou faux plafond, ou faux plafond invisible. 4. Finitions en aluminium anodisé argent mat et laque mate noire et blanche. 5. Assemblage rapide et efficace: **profil de couverture FT** (faux plafond et entre murs) pour un guide amovible qui permet une installation en phases et un accès direct à la quincaillerie à tout moment pendant l'installation. 6. **Profil STAR FTI** (Faux Plafond Invisible) : totalement caché dans le plafond avec la possibilité d'un **registre STAR FTI**: petit accès invisible compatible avec les systèmes sans SofTop, permettant de monter et démonter les ferrures sans endommager le plafond. 7. **Easy Clamp**, la solution la plus minimaliste grâce à son couvercle compact. 8. Rail de montage pour cloison séparatrice conçu pour optimiser et réduire le temps d'installation. 9. **Différentes options de roulements**: à friction ou à billes, toutes deux silencieuses et nécessitant un effort de glissement minimal. 10. **Possibilité d'un frein amortisseur double (SofTop)** pour SV-P70 Easy et SV-A90 Easy pour une fermeture douce et sans impacts. 11. Pas besoin de guide au sol, laissant ainsi la zone de passage libre d'obstacles. 12. Aucun usinage du verre n'est requis pour aucune des applications. 13. Certificat de qualité Applus selon EN 1527. Grade de Durabilité 6: 100 000 cycles de test, et Grade de Corrosion 3: 96 heures.

## Montaje a falso techo false ceiling mount | fixation a faux-plafond

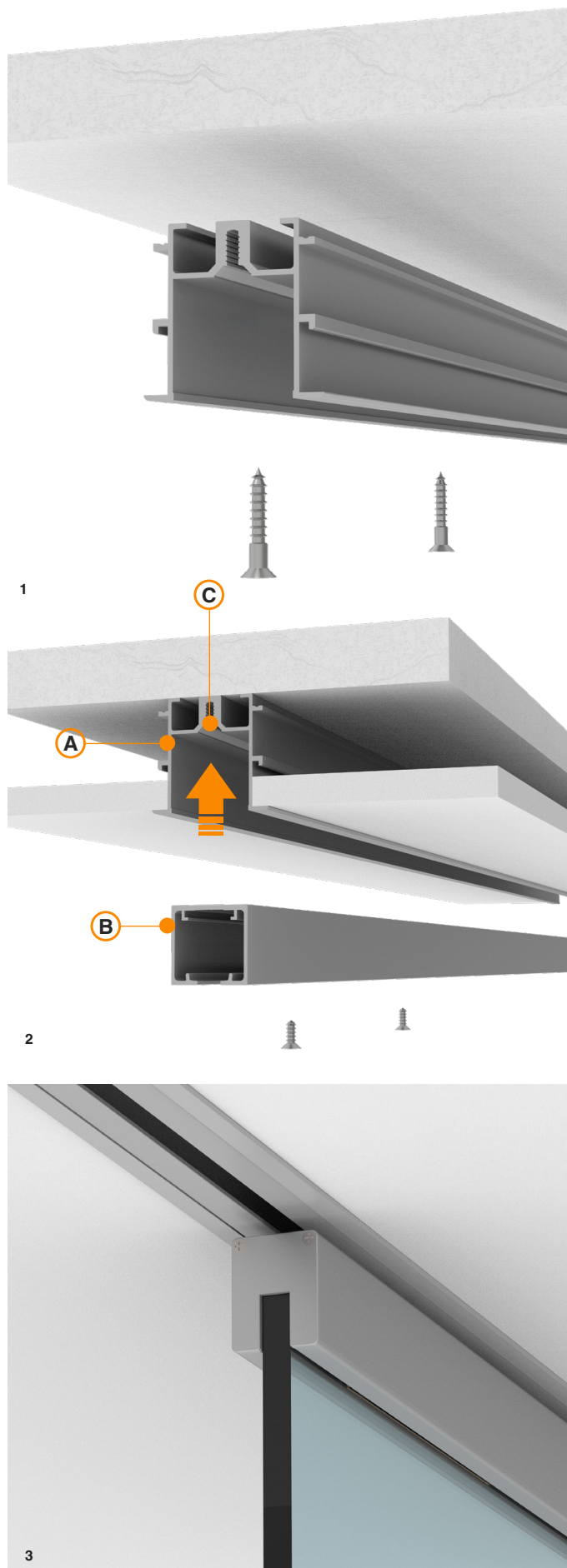

**A** Perfil funda FT | Support FT track | Rail de couverture FT. **B** Perfil Star | Star track | Rail Star. **C** Diseño de perfil con avellanado integrado | Track design with drilled countersink | Conception de rail avec fraisage intégré.

**Montaje entre paredes** mounting between walls | fixation entre les murs

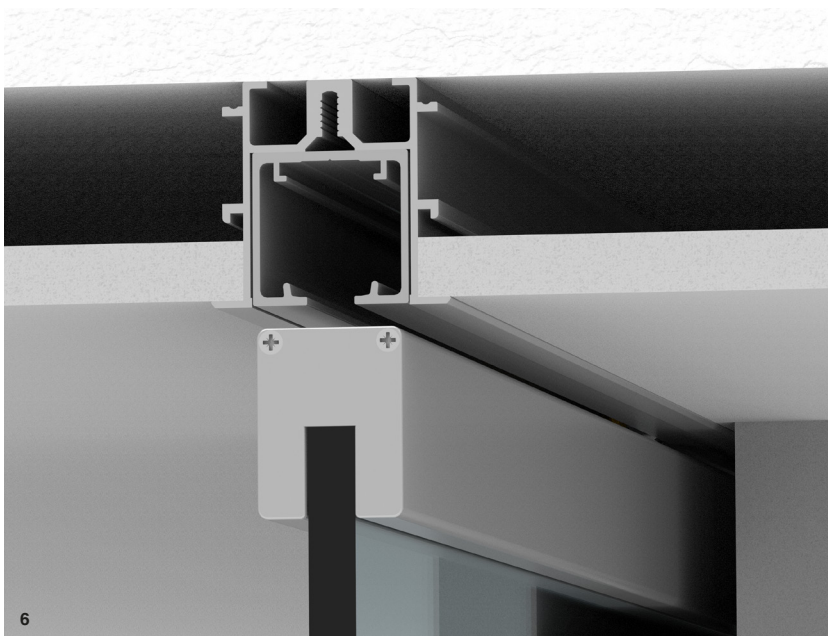
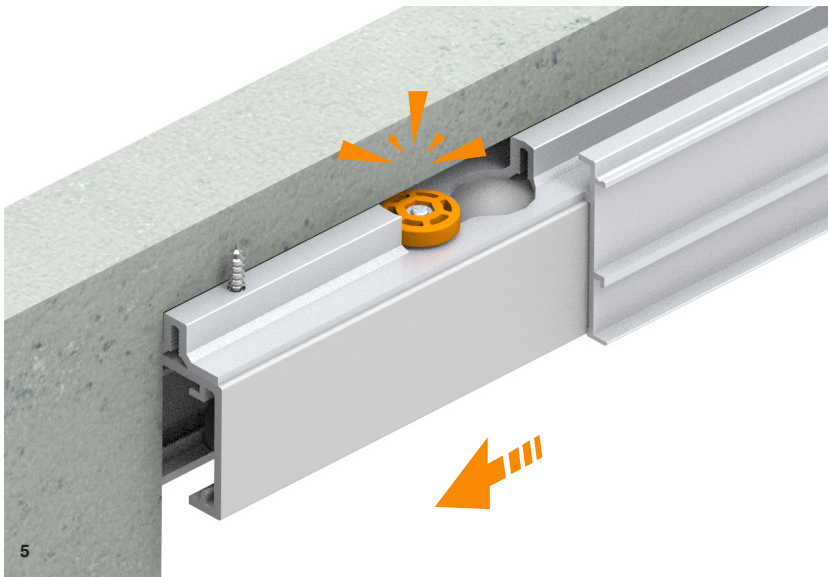
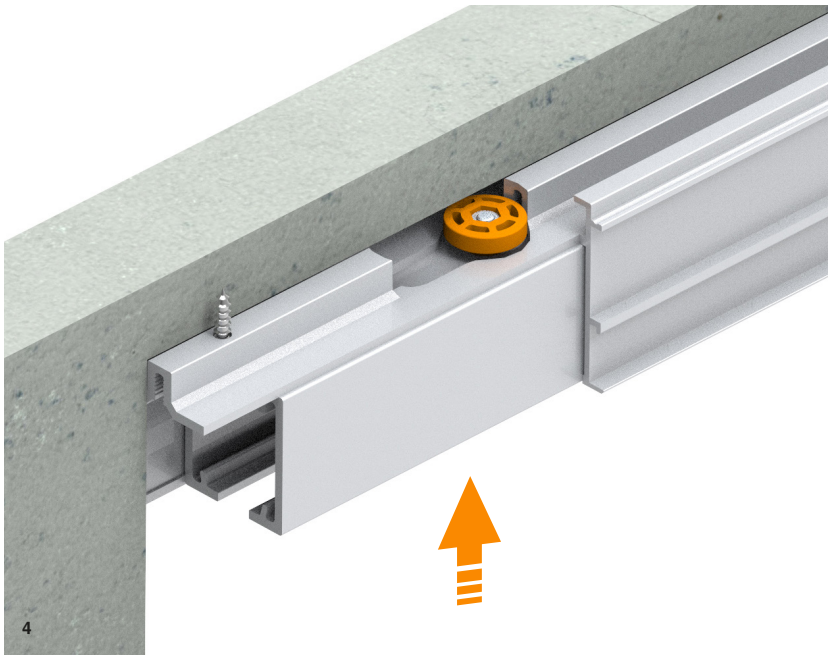

**Características técnicas**

Technical characteristics | Caractéristiques techniques

**Perfilería** Profiles | Profils

STANDARD 30x29 mm No SofTop	EXCELLENCE 33x33 mm	STAR 33x32 mm	EXCELLENCE VIDRIO FIJO   FIXED GLASS   VERRE FIXE 53x33 mm	STAR VIDRIO FIJO   FIXED GLASS   VERRE FIXE 50x32 mm
STAR FTI 48x47mm	REGISTRO   REGISTER   REGISTRE STAR FTI 48x47 mm No SofTop	STAR FT 53x32 mm	STAR FT VIDRIO FIJO   FIXED GLASS   VERRE FIXE 70x32 mm	SEPARADOR   SEPARATOR   SÉPARATEUR 49x43 mm
FUNDA   SUPPORT   COUVERTURE FT 51x48mm	CONJUNTO   SET   JEU FUNDA   SUPPORT   COUVERTURE FT + STAR 51x48 mm	20x20 mm	17x12 mm	21x20 mm
		20x15 mm		

**Especificaciones** Specifications | Spécification

8 mm	16 mm	10 mm	14 mm	RODAMIENTO A BOLAS BALL BEARING ROULEMENT À BILLES
SV-P70/SV-A90 EASY				
MÍN. 600 mm	<b>SofTop doble</b> MÍN. 600 mm	SOFTOP DOBLE MÁX.70Kg	SOFTOP DOBLE MÁX. 90Kg	

**Peso** Weight | Poids

40 kg	88 lb
60 kg	132 lb
70 kg	154 lb
90 kg	198 lb

**Producto certificado**

Product certificated | Produit certifié



Grado de Durabilidad 6: 100.000 ciclos de ensayo y Grado de Corrosión 3: 96h. | Durability Grade 6: 100,000 test cycles, and Corrosion Grade 3: 96h. | Grade de Durabilité 6: 100 000 cycles de test, et Grade de Corrosion 3: 96 heures.

**1, 2 y 3** Conjunto perfil Funda FT + Perfil Star, montaje a falso techo | Support FT + Star track set, false ceiling mounting | Ensemble Rail de couverture FT + Star, fixation a faux-plafond. **4, 5 y 6** Conjunto perfil Funda FT + Perfil Star, montaje entre paredes | Support FT + Star track set, mounting between walls | Ensemble Rail de couverture FT + Star, fixation entre les murs.



### Variantes de instalación

Installation possibilities | Variantes d'installation

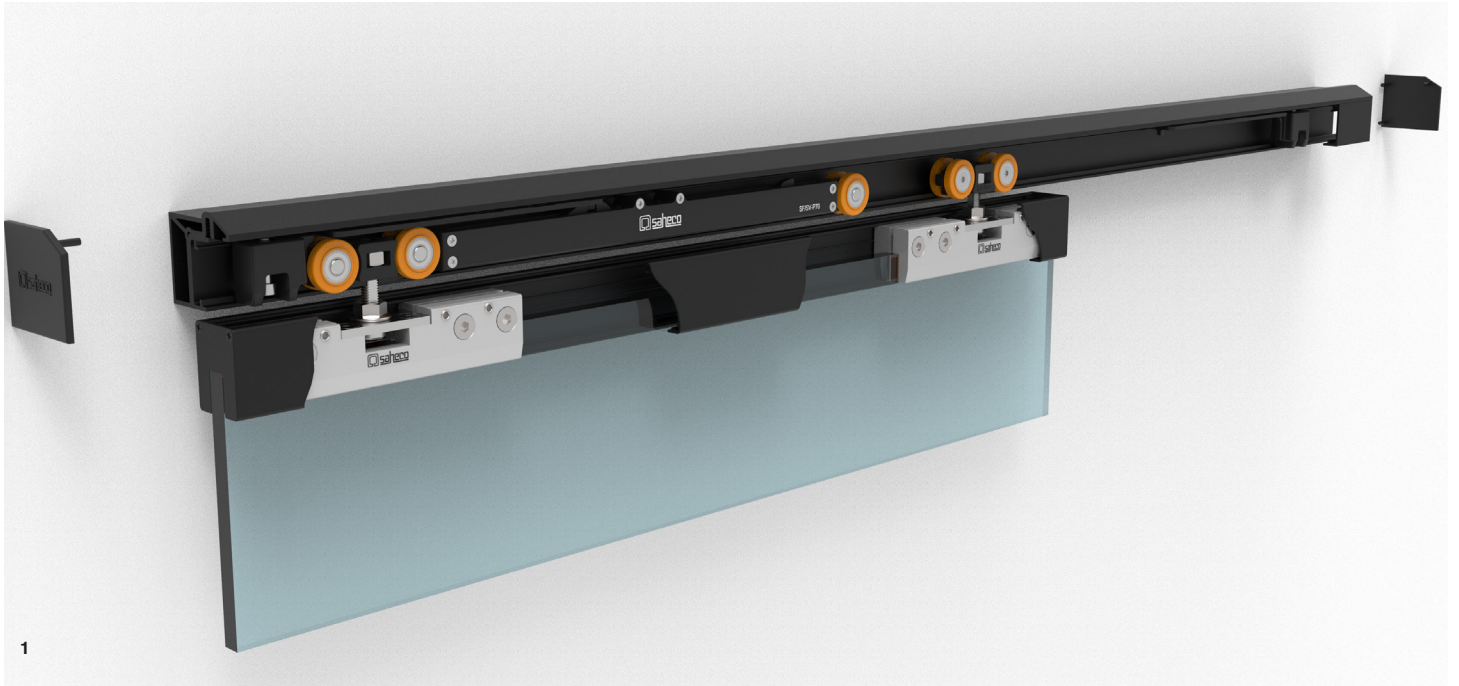

**1** Perfil separador+ perfil Star con juego de accesorios SV-P70 Easy. x1 SofTop doble | Separator track + Star track with SV-P70 Easy fitting set. x1 double SofTop | Rail séparateur+ rail Star avec garniture SV-P70 Easy. x1 double SofTop. **2** Perfil Star FT con juego SV-P70 Easy. Star FT track with SV-P70 Easy fitting set. Rail Star FT avec garniture SV-P70 Easy. **3** Perfil Star con juego SV-A90. Star track with SV-A90 fitting set. Rail Star avec garniture SV-A90.



### Variantes de instalación

Installation possibilities | Variantes d'installation

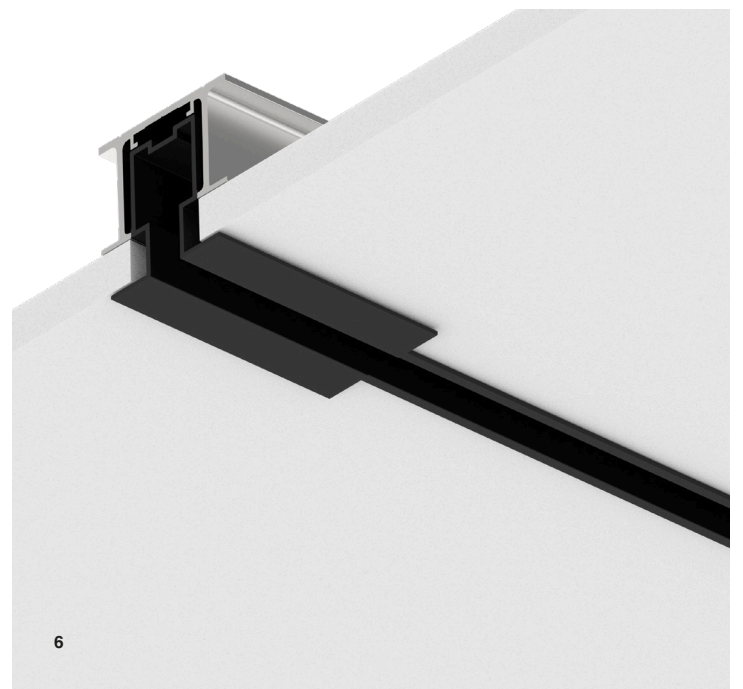
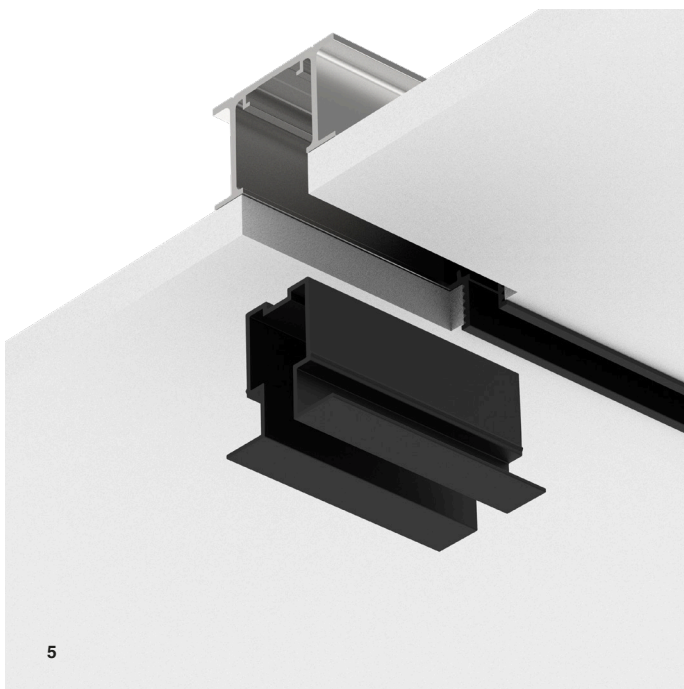
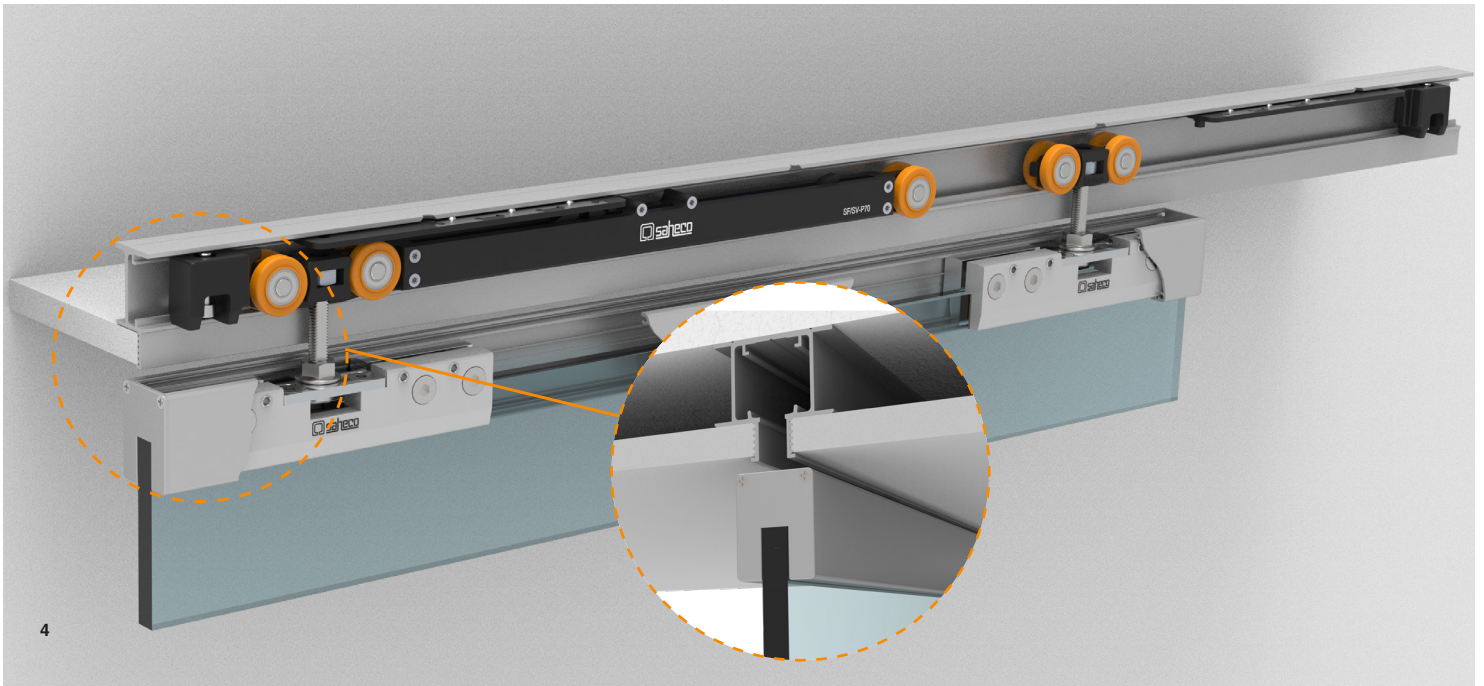

**4** Perfil FTI (Falso Techo Invisible) con juego de accesorios SF-RA P70 x1 SofTop doble | FTI Track (invisible false ceiling) with fitting set SF-RA P70 x1 double SofTop | Rail FTI (faux plafond invisible) avec garniture SF-RA P70 x1 double SofTop **5 y 6** Registro STAR FTI (para perfil FTI) | STAR FTI Register (for FTI profile) | Registre STAR FTI (pour profil FTI).

**Variantes de instalación**

Installation possibilities | Variantes d'installation

**PARED**  
WALL  
MUR

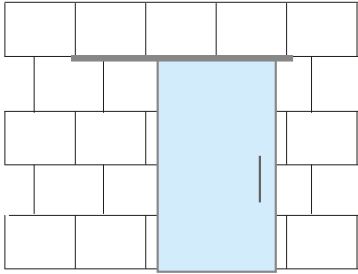

**PARED CON VIDRIO FJO**  
WALL WITH FIXED PANEL  
MUR AVEC VERRE FIXE

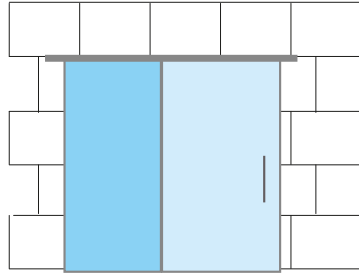

**TECHO**  
CEILING  
PLAFOND

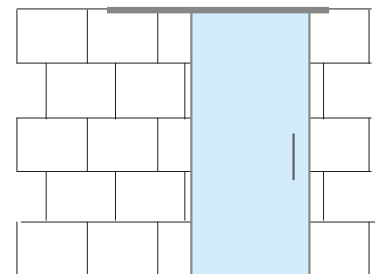

**TECHO CON VIDRIO FIJO**  
CEILING WITH FIXED PANEL  
PLAFOND AVEC VERRE FIXE

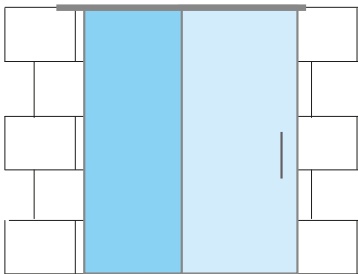

**FALSO TECHO**  
FALSE CEILING  
FAUX PLAFOND

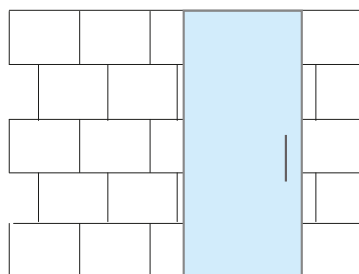

**FALSO TECHO CON VIDRIO FIJO**  
FALSE CEILING WITH FIXED PANEL  
FAUX PLAFOND AVEC VERRE FIXE

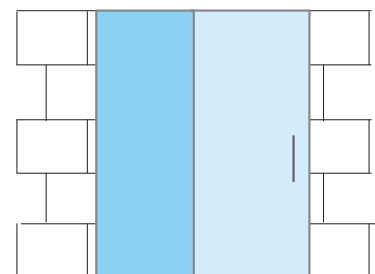

**ENTRE PAREDES | BETWEEN**  
WALLS | ENTRE MURS

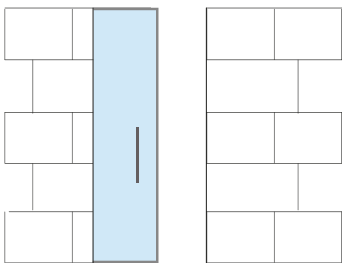

**FALSO TECHO INVISIBLE |**  
INVISIBLE FALSE CEILING |  
FAUX-PLAFOND INVISIBLE

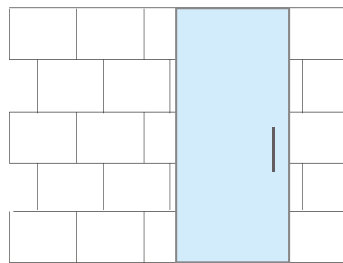

 **PUERTA CORREDERA | SLIDING DOOR | PORTE COULISSANTE**

 **VIDRIO FIJO | FIXED GLASS | VERRE FIXE**



Sección tipo

Cross-section | Section type (Cotas en mm | Dimensions in mm | Dimensions en mm)

MONTAJE A TECHO | CEILING MOUNTING | FIXATION À PLAFOND



STANDARD  
No SoftTop



EXCELLENCE



STAR

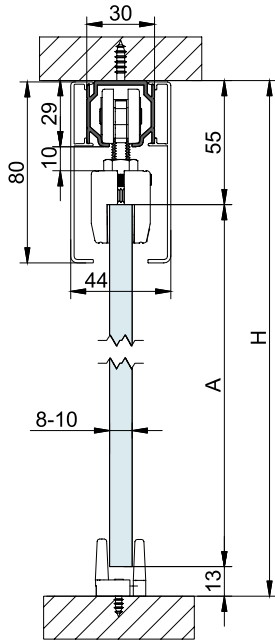

STANDARD  
A= H-68

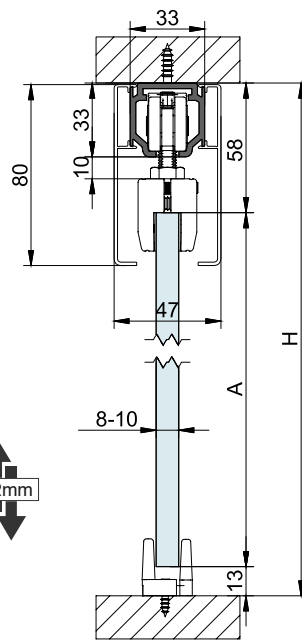

EXCELLENCE  
A= H-71

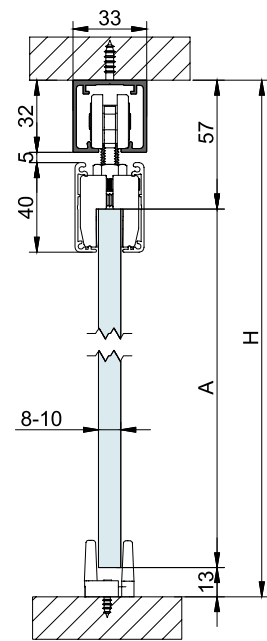

STAR  
A= H-70



EXCELLENCE  
VIDRIO FIJO



STAR  
VIDRIO FIJO

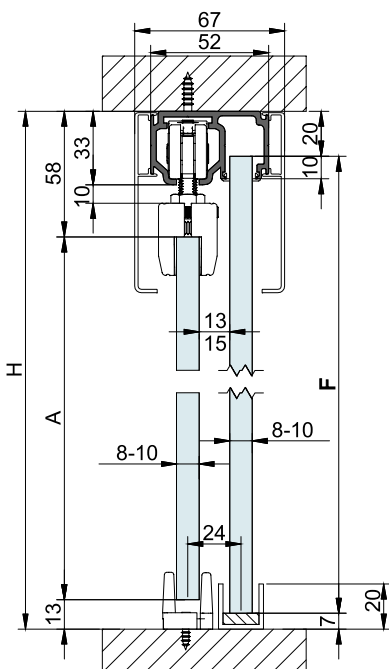

EXCELLENCE VIDRIO FIJO |  
FIXED GLASS | VERRE FIXE

A= H-71 F= H-29

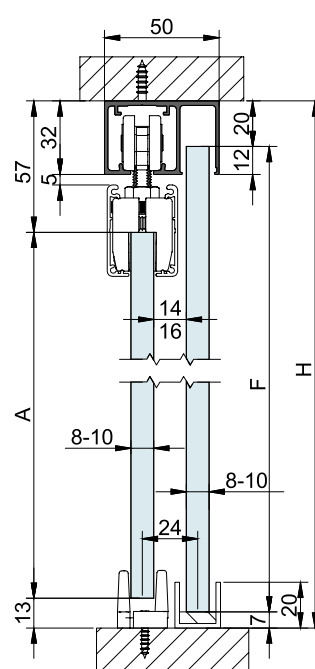

STAR VIDRIO FIJO |  
FIXED GLASS | VERRE FIXE

A= H-70 F= H-31

**Sección tipo**

Cross-section | Section type (Cotas en mm | Dimensions in mm | Dimensions en mm)

**MONTAJE A FALSO TECHO | FALSE CEILING MOUNTING | FIXATION À FAUX-PLAFOND**



STAR FT

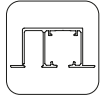

STAR FT  
VIDRIO FIJO



STAR FTI

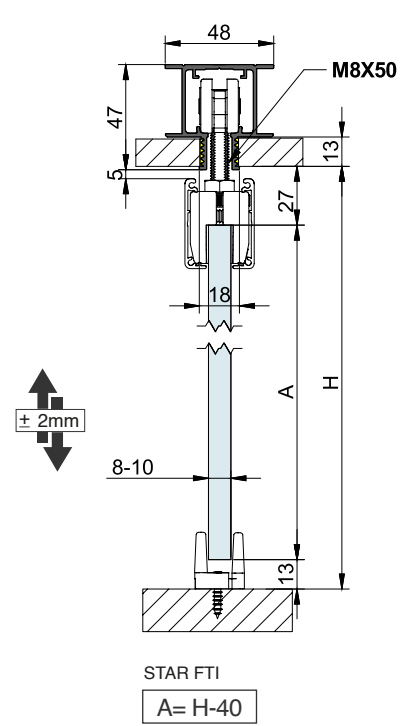
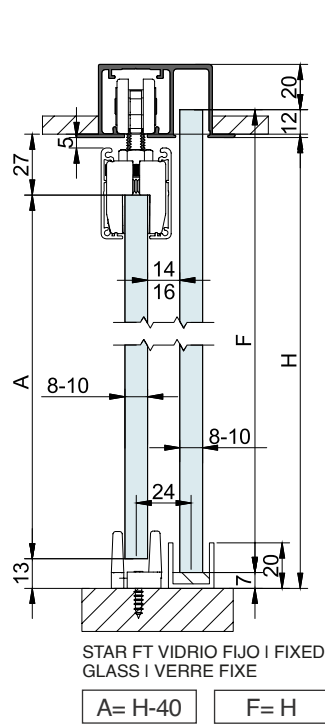
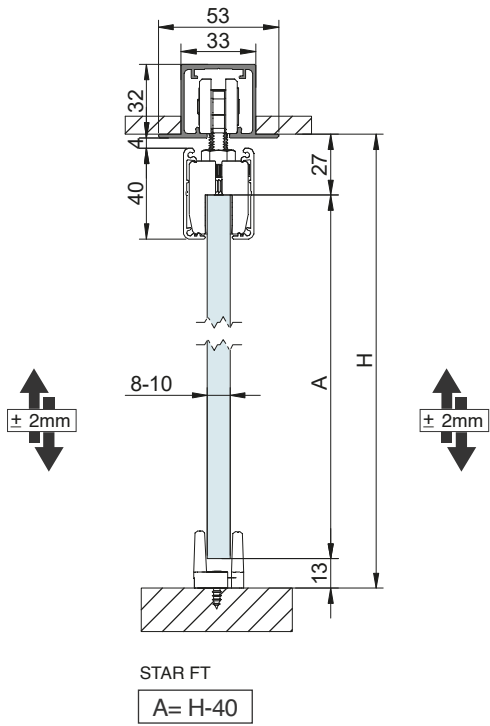



Sección tipo

Cross-section | Section type (Cotas en mm | Dimensions in mm | Dimensions en mm)

MONTAJE A PARED | WALL MOUNTING | FIXATION À MUR

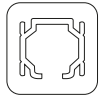

STANDARD  
No Softop



EXCELLENCE  
EXCELLENCE VIDRIO FIJO

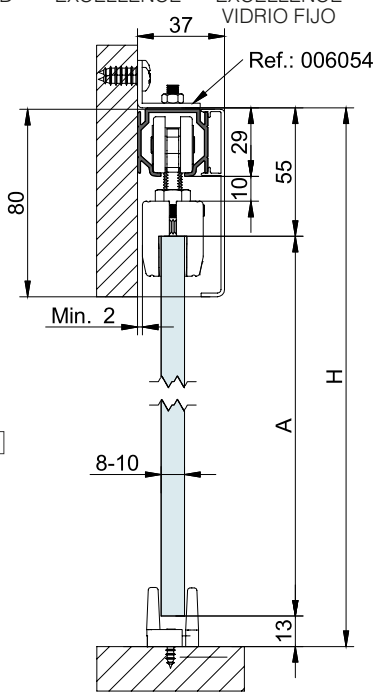
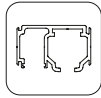

STANDARD  
A= H-68

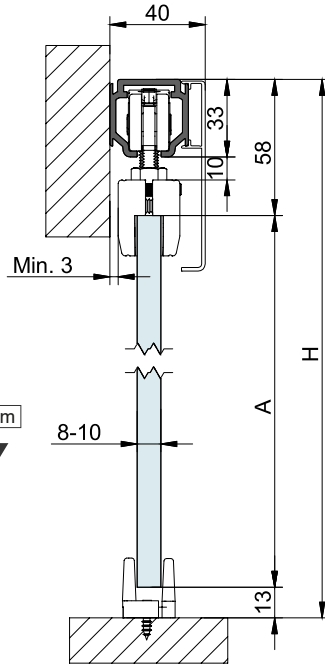

EXCELLENCE  
A= H-71

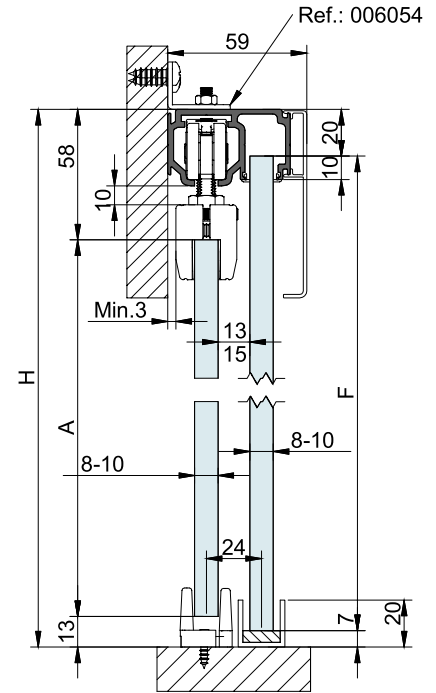

EXCELLENCE VIDRIO FIJO | FIXED GLASS | VERRE FIXE  
A= H-71 | F= H-29

MONTAJE ENTRE PAREDES | MOUNTING BETWEEN WALLS | MONTAGE ENTRE LES MURS

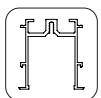

FUNDA FT

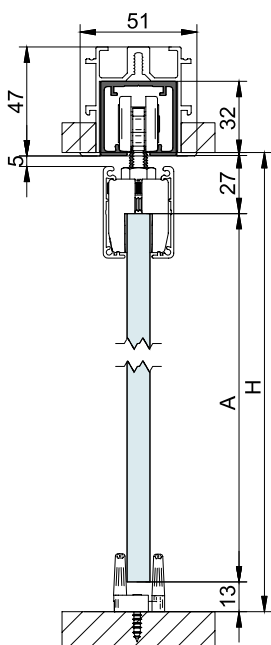

A= H-40



CONJUNTO I SET I JEU  
FUNDA I SUPPORT I  
COUVERTURE FT + STAR

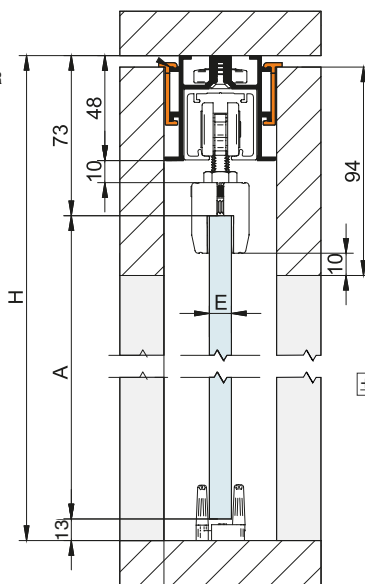

Sede interna (D\*)  
Internal opening (D\*)

A= H-86

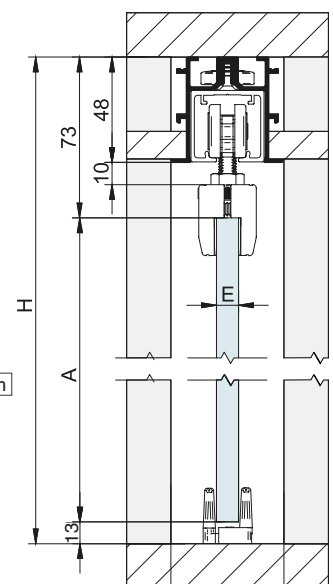

Sede interna (D\*)  
Internal opening (D\*)

A= H-86

**Componentes**

Components | Composants











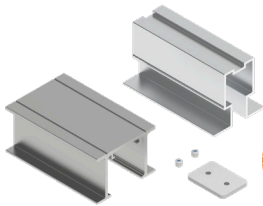

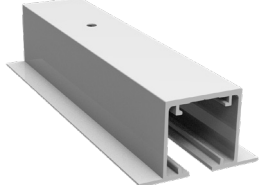

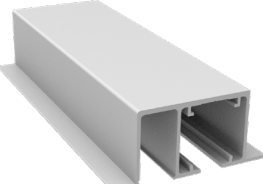
PERFILERÍA   PROFILES   PROFILS		Acabado	Cód.		
	<p>Perfil superior <b>Standard</b>                      Standard top track                      Rail supérieur Standard</p> <p>80kg                       30x29mm                      No SofTop</p>	<p>S</p> <p>MF</p>	<p>00 60 20                      00 60 30                      00 60 50</p> <p>00 61 20                      00 61 30                      00 61 50</p>	<p>2 m                      3 m                      5 m</p> <p>2 m                      3 m                      5 m</p>	<p>6 perfiles                      6 profiles                      6 profils</p>
	<p>Perfil superior <b>Excellence</b>. Montaje a techo                      Excellence top track. Ceiling mounting                      Rail supérieur Excellence. Fixation à plafond</p> <p>90kg                       33x33mm</p>	<p>S</p> <p>MF</p>	<p>0 105 24                      0 105 34                      0 105 54</p> <p>0 105 23                      0 105 33                      0 105 53</p>	<p>2 m                      3 m                      5 m</p> <p>2 m                      3 m                      5 m</p>	<p>2 perfiles                      2 profiles                      2 profils</p>
	<p>Perfil superior <b>Excellence</b>. Montaje a techo / pared                      Excellence top track. Ceiling / wall mounting                      Rail supérieur Excellence. Fixation à plafond / mur</p> <p>90kg                       33x33mm</p>	<p>S</p> <p>MF</p>	<p>0 105 20                      0 105 30                      0 105 50</p> <p>0 105 21                      0 105 31                      0 105 51</p>	<p>2 m                      3 m                      5 m</p> <p>2 m                      3 m                      5 m</p>	<p>2 perfiles                      2 profiles                      2 profils</p>
	<p>Perfil superior <b>Star</b>. Montaje a techo                      Star top track. Ceiling mounting                      Rail supérieur Star. Fixation à plafond</p> <p>90kg                       33x32mm</p>	<p>S</p> <p>MF</p> <p>BL</p> <p>WL</p>	<p>00 82 20                      00 82 30                      00 82 50</p> <p>00 82 23<sup>1</sup>                      00 82 33<sup>1</sup>                      00 82 53<sup>1</sup></p> <p>00 82 24                      00 82 34                      00 82 54</p> <p>00 82 29                      00 82 39                      00 82 59</p>	<p>2 m                      3 m                      5 m</p> <p>2 m                      3 m                      5 m</p> <p>2 m                      3 m                      5 m</p> <p>2 m                      3 m                      5 m</p>	<p>2 perfiles                      2 profiles                      2 profils</p>
	<p>Perfil superior <b>Excellence</b> para vidrio fijo                      Excellence top track for fixed glass                      Rail supérieur Excellence pour verre fixe</p> <p>90kg                       53x33mm</p>	<p>S</p> <p>MF</p>	<p>0 105 29                      0 105 39                      0 105 59</p> <p>0 105 27                      0 105 37                      0 105 57</p>	<p>2 m                      3 m                      5 m</p> <p>2 m                      3 m                      5 m</p>	<p>2 perfiles                      2 profiles                      2 profils</p>
	<p>Perfil superior <b>Star</b> para vidrio fijo                      Star top track for fixed glass                      Rail supérieur Star pour verre fixe</p> <p>90kg                       50x32mm</p>	<p>S</p> <p>MF</p> <p>BL</p> <p>WL</p>	<p>00 83 20                      00 83 30                      00 83 50</p> <p>00 83 21<sup>1</sup>                      00 83 31<sup>1</sup>                      00 83 51<sup>1</sup></p> <p>00 83 25                      00 83 35                      00 83 55</p> <p>00 83 27                      00 83 37                      00 83 57</p>	<p>2 m                      3 m                      5 m</p> <p>2 m                      3 m                      5 m</p> <p>2 m                      3 m                      5 m</p> <p>2 m                      3 m                      5 m</p>	<p>2 perfiles                      2 profiles                      2 profils</p>
	<p>Perfil <b>Star FTI</b>. Montaje a falso techo invisible                      Star FTI top track. Invisible false ceiling mounting                      Rail supérieur Star FTI. Fixation à faux-plafond invisible</p> <p>90kg                       48x47mm</p>	<p>S</p> <p>BL</p> <p>WL</p>	<p>00 79 20                      00 79 30                      00 79 50</p> <p>00 79 21                      00 79 31                      00 79 51</p> <p>00 79 22                      00 79 32                      00 79 52</p>	<p>2 m                      3 m                      5 m</p> <p>2 m                      3 m                      5 m</p> <p>2 m                      3 m                      5 m</p>	<p>2 perfiles                      2 profiles                      2 profils</p>

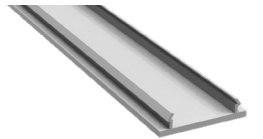
<sup>1</sup> Se sirve sin mecanizar | Is served without machining | Est servi sans usinage

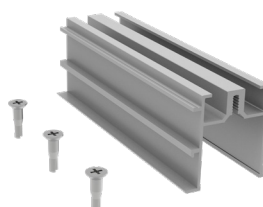

Componentes

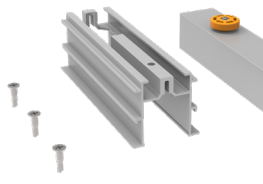
Components | Composants

PERFILERÍA   PROFILES   PROFILS	Acabado	Cód.		
 <p><b>Registro Star FTI.</b> Montaje a falso techo invisible Star FTI register. Invisible false ceiling mounting Registre Star FTI. Fixation à faux-plafond invisible</p> <p><b>NEW</b></p> <p>90kg  48x47 mm No SoftTop</p>	<p>S</p> <p>BL</p> <p>WL</p>	<p>00 79 13</p> <p>00 79 14</p> <p>00 79 15</p>	<p>75 mm</p> <p>75 mm</p> <p>75 mm</p>	<p>1 perfil 1 profile 1 profil</p>
 <p>Perfil superior <b>Star FT.</b> Montaje a falso techo Star FT top track. False ceiling mounting Rail supérieur Star FT. Fixation à faux-plafond</p> <p>90kg  53x32mm</p>	<p>S</p> <p>BL</p> <p>WL</p>	<p>00 82 25</p> <p>00 82 35</p> <p>00 82 55</p> <p>00 82 26</p> <p>00 82 36</p> <p>00 82 56</p> <p>00 82 21</p> <p>00 82 31</p> <p>00 82 51</p>	<p>2 m</p> <p>3 m</p> <p>5 m</p> <p>2 m</p> <p>3 m</p> <p>5 m</p> <p>2 m</p> <p>3 m</p> <p>5 m</p>	<p>2 perfiles 2 profiles 2 profils</p>
 <p>Perfil superior <b>Star FT</b> para vidrio fijo Star FT top track for fixed glass Rail supérieur Star FT pour verre fixe</p> <p>90kg  70x32mm</p>	<p>S</p> <p>BL</p> <p>WL</p>	<p>00 83 23</p> <p>00 83 33</p> <p>00 83 53</p> <p>00 83 24</p> <p>00 83 34</p> <p>00 83 54</p> <p>00 83 26</p> <p>00 83 36</p> <p>00 83 56</p>	<p>2 m</p> <p>3 m</p> <p>5 m</p> <p>2 m</p> <p>3 m</p> <p>5 m</p> <p>2 m</p> <p>3 m</p> <p>5 m</p>	<p>2 perfiles 2 profiles 2 profils</p>
 <p>Embellecedor para perfil superior <b>Excellence / Star / Star FT</b> para vidrio fijo Excellence / Star / Star FT trim for fixed glass track Enjoliveur Excellence / Star / Star FT pour rail avec panneau fixe</p>	<p>PPS</p> <p>PPW</p> <p>PPB</p>	<p>00 80 74</p> <p>00 80 72</p> <p>00 80 73</p>	<p>3 m</p> <p>3 m</p> <p>3 m</p>	<p>1 perfil 1 profile 1 profil</p>
 <p>Perfil superior separador <b>Excellence / Star.</b> Montaje a pared Excellence / Star separator top track. Wall mounting Rail supérieur séparateur Excellence / Star. Fixation à mur</p> <p> 49x43mm</p>	<p>S</p> <p>BL</p> <p>WL</p>	<p>00 82 27<sup>1</sup></p> <p>00 82 37<sup>1</sup></p> <p>00 82 57<sup>1</sup></p> <p>00 82 28<sup>1</sup></p> <p>00 82 38<sup>1</sup></p> <p>00 82 58<sup>1</sup></p> <p>00 83 28<sup>1</sup></p> <p>00 83 38<sup>1</sup></p> <p>00 83 58<sup>1</sup></p>	<p>2 m</p> <p>3 m</p> <p>5 m</p> <p>2 m</p> <p>3 m</p> <p>5 m</p> <p>2 m</p> <p>3 m</p> <p>5 m</p>	<p>1 perfil 1 profile 1 profil</p>
 <p>Perfil <b>Funda FT.</b> Montaje a falso techo Support FT track. False ceiling mounting Rail de couverture FT. Fixation à faux-plafond</p> <p>Se sirve sin mecanizar   Is served without machining   Est servi sans usinage</p> <p>Compatible   Suitable</p> <p>90kg  51x48mm</p> <p> EXCELLENCE  STAR</p>	<p>S</p> <p>BL</p> <p>WL</p>	<p>00 85 22<sup>2</sup></p> <p>00 85 32<sup>2</sup></p> <p>00 85 52<sup>2</sup></p> <p>00 85 23<sup>2</sup></p> <p>00 85 33<sup>2</sup></p> <p>00 85 53<sup>2</sup></p> <p>00 85 24<sup>2</sup></p> <p>00 85 34<sup>2</sup></p> <p>00 85 54<sup>2</sup></p>	<p>2 m</p> <p>3 m</p> <p>5 m</p> <p>2 m</p> <p>3 m</p> <p>5 m</p> <p>2 m</p> <p>3 m</p> <p>5 m</p>	<p>1 perfil 1 profile 1 profil</p>
 <p>Conjunto   Perfil <b>Funda FT + Star.</b> Montaje entre paredes / falso techo. Support FT + Star track set. Mounting between walls / false ceiling. Jeu rail de couverture FT + Star. Fixation entre les murs / faux-plafond.</p> <p>Fijación en bayoneta   Bayonet mounting   Montage à baïonnette <b>Pocket</b></p> <p>90kg  51x48mm</p>	<p>S</p> <p>BL</p> <p>WL</p>	<p>00 85 25<sup>3</sup></p> <p>00 85 35<sup>3</sup></p> <p>00 85 45<sup>3</sup></p> <p>00 85 65<sup>3</sup></p> <p>00 85 26<sup>3</sup></p> <p>00 85 36<sup>3</sup></p> <p>00 85 46<sup>3</sup></p> <p>00 85 66<sup>3</sup></p> <p>00 85 27<sup>3</sup></p> <p>00 85 37<sup>3</sup></p> <p>00 85 47<sup>3</sup></p> <p>00 85 67<sup>3</sup></p>	<p>2 m</p> <p>3 m</p> <p>4 m</p> <p>6 m</p> <p>2 m</p> <p>3 m</p> <p>4 m</p> <p>6 m</p> <p>2 m</p> <p>3 m</p> <p>4 m</p> <p>6 m</p>	<p>1 perfil 1 profile 1 profil</p>

<sup>1</sup> Para perfil superior separador **Excellence / Star**, montaje a pared de 2 m, 3 m, 5 m | \*For Star / Excellence Full width side fixing profile 2m, 3m or 5m | \*Pour profil équerre pour fixation murale Star / Excellence 2m, 3m ou 5m. **2 m - 10 tornillos | screw | vis 3 m - 15 tornillos | screw | vis 5 m - 25 tornillos | screw | vis**

<sup>2</sup> Se sirve con tornillería | <sup>1</sup>Served with screws | <sup>1</sup>Servi avec vis. **2 m - 6 tornillos | screw | vis 3 m - 8 tornillos | screw | vis 5 m - 13 tornillos | screw | vis**

<sup>3</sup> Se sirve con clip tapeta madera | <sup>2</sup>Served with clip for timber pelmet | <sup>2</sup>Servi avec clip pour cache en bois. **2 y 3 m - 8 clips 4 y 6 m - 12 clips**

**S** Aluminio anodizado plata mate  
Satin anodized aluminium  
Aluminium anodisé argent

**BL** Aluminio lacado negro mate  
Matt black lacquered aluminium  
Aluminium anodisé laqué noir mat

**WL** Aluminio lacado blanco mate  
Matt white lacquered aluminium  
Aluminium anodisé laqué blanc mat







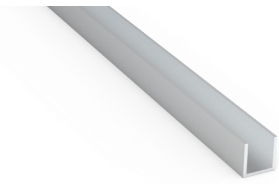

**PPS** Plástico pintado plata  
Plastic painted silver  
PVC finition peinture argent

**PPB** Plástico pintado negro  
Black painted plastic  
PVC peinture noir

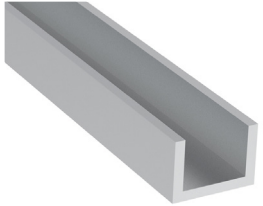
**PPW** Plástico pintado blanco  
Plastic painted white  
PVC finition peinture blanche

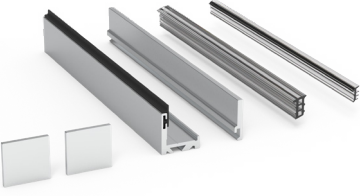
**Componentes**

Components | Composants

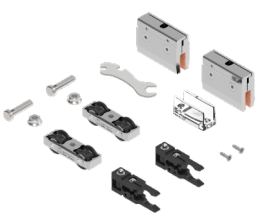
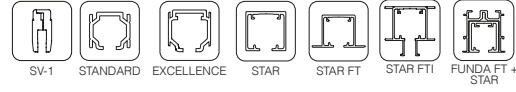
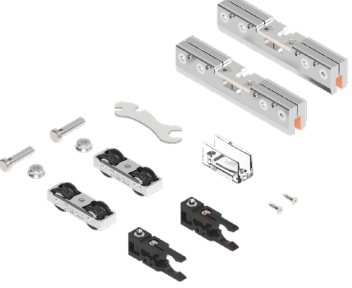
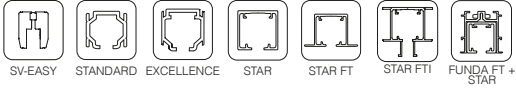
PERFILERÍA   PROFILES   PROFILS		Acabado	Cód.		
	<p>Perfil inferior para vidrio fijo de 8-10-12mm                      Bottom track for fixed glass of 8-10-12mm                      Rail inférieur pour verre fixe 8-10-12mm</p>  20x20mm	<b>S</b>	00 87 15 00 87 30 00 87 60	1,5 m 3 m 6 m	2 perfiles 2 profiles 2 profils
	<p>Perfil inferior para vidrio fijo de 8-10-12mm                      Bottom track for fixed glass of 8-10-12mm                      Rail inférieur pour verre fixe 8-10-12mm</p>  17x12mm	<b>S</b>  <b>WL</b>  <b>BL</b>	00 87 24 00 87 34 00 87 64  00 71 96 00 71 91 00 71 97  00 71 86 00 71 81 00 71 87	2 m 3 m 6 m  2 m 3 m 6 m  2 m 3 m 6 m	2 perfiles 2 profiles 2 profils
	<p>Perfil inferior entrada frontal para vidrio fijo de 8-10-12 mm                      Bottom track front entry for fixed glass of 8-10-12mm                      Rail inférieur entrée frontale pour verre fixe 8-10-12mm</p>  21x20mm	<b>S</b>  <b>WL</b>  <b>BL</b>	0 110 22 <sup>1</sup> 0 110 32 <sup>1</sup> 0 110 62 <sup>1</sup>  0 110 24 <sup>1</sup> 0 110 34 <sup>1</sup> 0 110 64 <sup>1</sup>  0 110 25 <sup>1</sup> 0 110 35 <sup>1</sup> 0 110 55 <sup>1</sup>	2 m 3 m 6 m  2 m 3 m 6 m  2 m 3 m 6 m	1 perfil 1 profile 1 profil
	<p>Perfil inferior con burlete de 8-10-12mm                      Bottom track with brush of 8-10-12mm                      Rail inférieur avec bourrelet de 8-10-12mm</p>  20x15mm	<b>S</b>	00 41 22 00 41 32 00 41 62	2 m 3 m 6 m	1 perfil 1 profile 1 profil
JUEGOS   SETS   JEUX		Acabado	Cód.		
	<p>Juego de accesorios <b>SV-A40</b>                      SV-A40 Fitting set                      Garniture SV-A40</p>  40kg		00 56 00		1 juego 1 set 1 jeu
	<p>Juego de accesorios <b>SV-A60 EASY x2</b> Freno retenedor                      SV-A60 EASY Fitting set x2 Retaining stopper                      Garniture SV-A60 EASY x2 Frein de retenue</p>  60kg		00 66 08		1 juego 1 set 1 jeu

<sup>1</sup>El perfil incluye junta + juegos de tapas laterales | This profile includes PVC joints + set of end caps | <sup>1</sup>Le profil inclue jointes plastiques + capuchons finals

2 m ..... 2 juegos de tapas | 2 set of caps | 2 set de caupuchons finals  
 3 m ..... 4 juegos de tapas | 4 set of caps | 4 set de caupuchons finals  
 6 m ..... 6 juegos de tapas | 6 set of caps | 6 set de caupuchons finals

**S** Aluminio anodizado plata mate  
 Satin anodized aluminium  
 Aluminium anodisé argent

**WL** Aluminio lacado blanco mate  
 Matt white lacquered aluminium  
 Aluminium anodisé laqué blanc mat

**BL** Aluminio lacado negro mate  
 Matt black lacquered aluminium  
 Aluminium anodisé laqué noir mat





Componentes

Components | Composants

JUEGOS   SETS   JEUX	Acabado	Cód.		
		00 66 09		1 juego 1 set 1 jeu
		00 66 12		1 juego 1 set 1 jeu
		00 86 00		1 juego 1 set 1 jeu
		00 86 08		1 juego 1 set 1 jeu
		00 86 09		1 juego 1 set 1 jeu

**Componentes**

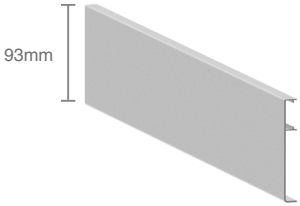
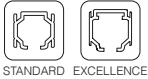
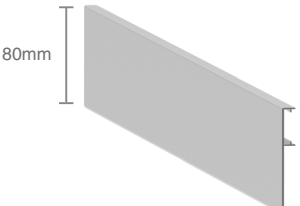
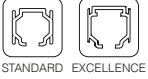
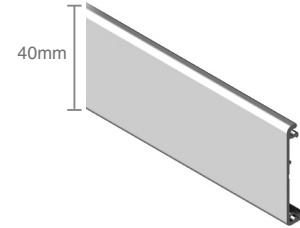
Components | Composants

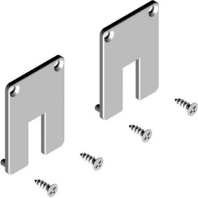
ACCESORIOS   ACCESSORIES   ACCESSOIRES		Acabado	Cód.		
 <p>93mm</p>	<p>Tapeta <b>SV-1 / SV-2</b> SV-1 / SV-2 Pelmet cover Cache SV-1 / SV-2</p>  <p>STANDARD EXCELLENCE</p>	<p><b>S</b></p> <p><b>WL</b></p> <p><b>BL</b></p>	<p>00 64 20</p> <p>00 64 30</p> <p>00 64 50</p>	<p>2 m</p> <p>3 m</p> <p>5 m</p>	<p>2 perfiles</p> <p>2 profiles</p> <p>2 profils</p>
			<p>00 64 21</p> <p>00 64 31</p> <p>00 64 51</p>	<p>2 m</p> <p>3 m</p> <p>5 m</p>	
 <p>80mm</p>	<p>Tapeta <b>SV-EASY</b> SV-EASY Pelmet cover Cache SV-EASY</p>  <p>STANDARD EXCELLENCE</p>	<p><b>S</b></p> <p><b>WL</b></p> <p><b>BL</b></p>	<p>00 68 20</p> <p>00 68 30</p> <p>00 68 50</p>	<p>2 m</p> <p>3 m</p> <p>5 m</p>	<p>2 perfiles</p> <p>2 profiles</p> <p>2 profils</p>
			<p>00 68 21</p> <p>00 68 31</p> <p>00 68 51</p>	<p>2 m</p> <p>3 m</p> <p>5 m</p>	
 <p>40mm</p>	<p>Tapeta para pinza <b>EASY</b> EASY clamp pelmet cover Cache-pinçe EASY</p>  <p>SV-EASY</p>	<p><b>S</b></p> <p><b>WL</b></p> <p><b>BL</b></p>	<p>00 64 29</p> <p>00 64 39</p>	<p>2 m</p> <p>3 m</p>	<p>2 perfiles</p> <p>2 profiles</p> <p>2 profils</p>
			<p>00 67 21</p> <p>00 67 31</p>	<p>2 m</p> <p>3 m</p>	
	<p>Juego de tapas laterales pinza <b>EASY</b> EASY Clamp lateral caps Jeu capuchons latéraux EASY</p>	<p><b>S</b></p> <p><b>WL</b></p> <p><b>BL</b></p>	<p>00 80 77</p> <p>00 80 78</p>	<p>8 mm</p> <p>10 mm</p>	<p>1 juego</p> <p>1 set</p> <p>1 jeu</p>
			<p>00 80 93</p> <p>00 80 94</p>	<p>8 mm</p> <p>10 mm</p>	
			<p>00 80 96</p> <p>00 80 97</p>	<p>8 mm</p> <p>10 mm</p>	



## Componentes

### Components | Composants

ACCESORIOS   ACCESSORIES   ACCESSOIRES		Acabado	Cód.		
 <p>39x93x2</p>	<p>Juego de tapas laterales <b>SV-1/SV-2</b>. Montaje a pared. Perfil superior + tapeta SV-1/SV-2 Lateral cap set. Wall mounting. Top track + pelmet cover Jeu capuchons latéraux SV-1/SV-2. Fixation à mur. Rail supérieur + cache</p>	<b>S</b>	00 61 15 0 105 05	Standard Excellence	1 juego 1 set 1 jeu
		<b>WL</b>	00 61 26 0 105 01	Standard Excellence	
		<b>BL</b>	00 61 27 0 105 71	Standard Excellence	
 <p>48x93x2</p>	<p>Juego de tapas laterales <b>SV-1/SV-2</b>. Montaje a techo. Tapeta + perfil superior + tapeta SV-1/SV-2 Lateral cap set. Ceiling mounting. Pelmet cover + top track + pelmet cover Jeu capuchons latéraux SV-1/SV-2. Fixation à plafond. Cache + rail supérieur + cache</p>	<b>S</b>	00 61 13 0 105 03	Standard Excellence	1 juego 1 set 1 jeu
		<b>WL</b>	00 61 36 0 105 74	Standard Excellence	
		<b>BL</b>	00 61 37 0 105 75	Standard Excellence	
 <p>58x105x2</p>	<p>Juego de tapas laterales <b>SV-1/SV-2</b>. Montaje a pared. Perfil superior separador + perfil superior + tapeta SV-1/SV-2 Lateral cap set. Wall mounting. Separator top track + top track + pelmet cover Jeu capuchons latéraux SV-1/SV-2. Fixation à mur. Rail supérieur séparateur + rail supérieur + cache</p>	<b>S</b>	0 105 85	Excellence	1 juego 1 set 1 jeu
		<b>WL</b>	0 105 87	Excellence	
		<b>BL</b>	0 105 88	Excellence	
 <p>61x94x2</p>	<p>Juego de tapas laterales <b>SV-1/SV-2</b>. Montaje a techo. Tapeta + perfil superior Excellence para vidrio fijo SV-1/SV-2 Lateral cap set. Ceiling mounting. Pelmet cover + Excellence top track for fixed glass Jeu capuchons latéraux SV-1/SV-2. Fixation à plafond. Cache + Rail supérieur Excellence avec verre fixe</p>	<b>S</b>	0 105 96	Excellence	1 juego 1 set 1 jeu
		<b>WL</b>	0 105 98	Excellence	
		<b>BL</b>	0 105 99	Excellence	
 <p>70x94x2</p>	<p>Juego de tapas laterales <b>SV-1/SV-2</b>. Montaje a techo. Tapeta + perfil superior Excellence para vidrio fijo + tapeta SV-1/SV-2 Lateral cap set. Ceiling mounting. Pelmet cover + Excellence top track for fixed glass + pelmet cover Jeu capuchons latéraux SV-1/SV-2. Fixation à plafond. Cache + Rail supérieur Excellence avec verre fixe + Cache</p>	<b>S</b>	0 105 52	Excellence	1 juego 1 set 1 jeu
		<b>WL</b>	0 105 56	Excellence	
		<b>BL</b>	0 105 22	Excellence	



Aluminio anodizado plata mate  
Satin anodized aluminium  
Aluminium anodisé argent



Aluminio lacado blanco mate  
Matt white lacquered aluminium  
Aluminium anodisé laqué blanc mat



Aluminio lacado negro mate  
Matt black lacquered aluminium  
Aluminium anodisé laqué noir mat

**Componentes**



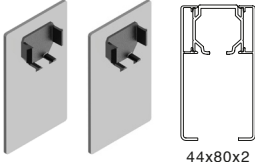
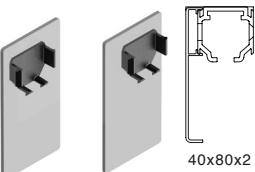
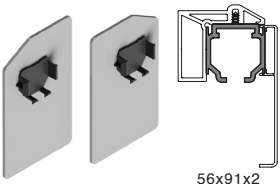
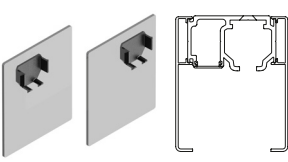
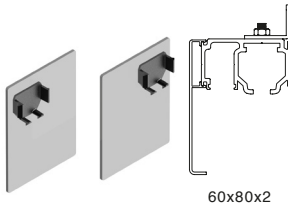



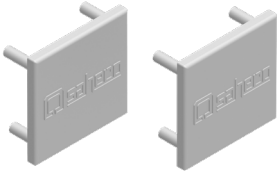

Components | Composants

ACCESORIOS   ACCESSORIES   ACCESSOIRES		Acabado	Cód.		
 <p>44x80x2</p>	<p>Juego de tapas laterales <b>EASY</b>. Montaje a techo.                      Tapeta + perfil superior + tapeta                      EASY Lateral cap set. Ceiling mounting. Pelmet cover + top track + pelmet cover                      Jeu capuchons latéraux EASY. Fixation à plafond.                      Cache + rail supérieur + cache</p>	<b>S</b>	00 61 76 0 105 10	Standard Excellence	1 juego 1 set 1 jeu
		<b>WL</b>	00 61 77 0 105 14	Standard Excellence	
		<b>BL</b>	00 61 94 0 105 80	Standard Excellence	
 <p>40x80x2</p>	<p>Juego de tapas laterales <b>EASY</b>. Montaje a pared.                      Tapeta + perfil superior                      EASY Lateral cap set. Wall mounting. Pelmet cover + top track                      Jeu capuchons latéraux EASY. Fixation à mur. Cache + rail supérieur</p>	<b>S</b>	00 61 70 0 105 11	Standard Excellence	1 juego 1 set 1 jeu
		<b>WL</b>	00 61 71 0 105 15	Standard Excellence	
		<b>BL</b>	00 61 92 0 105 81	Standard Excellence	
 <p>56x91x2</p>	<p>Juego de tapas laterales <b>EASY</b>. Montaje a pared.                      Perfil superior separador + perfil superior Excellence + tapeta                      EASY Lateral cap set. Wall mounting. Separator top track + Excellence top track + pelmet cover                      Jeu capuchons latéraux EASY. Fixation à mur. Rail supérieur séparateur + Rail supérieur Excellence + cache</p>	<b>S</b>	0 105 90	Excellence	1 juego 1 set 1 jeu
		<b>WL</b>	0 105 92	Excellence	
		<b>BL</b>	0 105 95	Excellence	
 <p>67x80x2</p>	<p>Juego de tapas laterales <b>EASY</b>. Montaje a techo.                      Tapeta + perfil superior Excellence para vidrio fijo + tapeta                      EASY Lateral cap set. Ceiling mounting. Pelmet cover + Excellence top track for fixed glass + pelmet cover                      Jeu capuchons latéraux EASY. Fixation à plafond.                      Cache + profil supérieur Excellence avec verre fixe + cache</p>	<b>S</b>	0 105 12	Excellence	1 juego 1 set 1 jeu
		<b>WL</b>	0 105 16	Excellence	
		<b>BL</b>	0 105 83	Excellence	
 <p>60x80x2</p>	<p>Juego de tapas laterales <b>EASY</b>. Montaje a pared.                      Tapeta + perfil superior Excellence para vidrio fijo                      EASY Lateral cap set. Wall mounting. Pelmet cover + Excellence top track for fixed glass                      Jeu capuchons latéraux EASY. Fixation à mur. Cache + rail supérieur Excellence avec verre fixe</p>	<b>S</b>	0 105 13	Excellence	1 juego 1 set 1 jeu
		<b>WL</b>	0 105 17	Excellence	
		<b>BL</b>	0 105 84	Excellence	

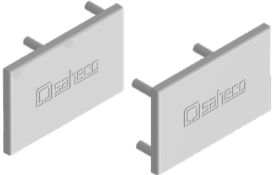

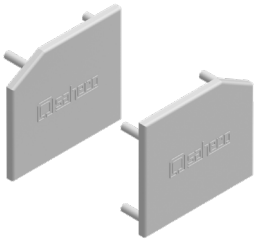
## Componentes

### Components | Composants

ACCESORIOS   ACCESSORIES   ACCESSOIRES		Acabado	Cód.		
 <p>Juego de tapas laterales <b>Star</b>. Montaje a techo/pared. Star lateral cap set. Ceiling / wall mounting Jeu capuchons latéraux Star. Fixation à plafond / mur</p>  <p>33x32mm</p>	<p><b>PS</b></p> <p><b>PB</b></p> <p><b>WP</b></p>	<p>00 52 10</p> <p>00 52 11</p> <p>00 52 17</p>			<p>1 juego</p> <p>1 set</p> <p>1 jeu</p>
 <p>Juego de tapas laterales <b>Star</b> para vidrio fijo. Montaje a techo/pared. Star lateral cap set for fixed glass. Ceiling / wall mounting Jeu capuchons latéraux Star avec verre fixée. Fixation à plafond / mur</p>  <p>50x32mm</p>	<p><b>PS</b></p> <p><b>PB</b></p> <p><b>WP</b></p>	<p>00 52 13</p> <p>00 52 14</p> <p>00 52 19</p>			<p>1 juego</p> <p>1 set</p> <p>1 jeu</p>
 <p>Juego de tapas laterales <b>Star</b>. Montaje a pared. Perfil superior separador Excellence / Star + perfil superior Star Star lateral cap set. Wall mounting. Excellence / Star separator top track + Star top track Jeu capuchons latéraux Star. Fixation à mur. Rail supérieur séparateur Excellence / Star + Rail supérieur Star</p>  <p>49x43mm</p>	<p><b>PS</b></p> <p><b>PB</b></p> <p><b>WP</b></p>	<p>00 52 15</p> <p>00 52 16</p> <p>00 52 18</p>			<p>1 juego</p> <p>1 set</p> <p>1 jeu</p>
 <p>Juego roldanas <b>SV-A40 / SV-A60</b> SV-A40 / SV-A60 Roller set Jeu de galets SV-A40 / SV-A60</p> <p><b>40-60kg</b></p>		<p>00 66 55</p>			<p>5 juegos</p> <p>5 sets</p> <p>5 jeux</p>
 <p>Roldana <b>SV-P70</b> con tornillo SV-P70 Roller with screw Galet SV-P70 avec vis</p> <p><b>70kg</b></p> 		<p>00 72 04</p>			<p>25 piezas</p> <p>25 pieces</p> <p>25 pièces</p>

**PS** Plástico plata  
Plastic silver  
PVC argent

**PB** Plástico negro  
Black plastic  
PVC noir

**WP** Plástico blanco  
White plastic  
Plastique blanc

**Componentes**

Components | Composants

ACCESORIOS   ACCESSORIES   ACCESSOIRES		Acabado	Cód.		
	<p>Juego roldanas <b>SV-A90</b>                      SV-A90 Roller set                      Jeu de montures SV-A90</p> <p>90kg </p>		00 86 55		5 juegos 5 sets 5 jeux
	<p>Juego de pinzas regulables <b>SV-1</b>                      SV-1 Adjustable clamps set                      Jeu pinces réglables SV-1</p> <p>40kg  SV-1</p>		00 40 58		1 juego 1 set 1 jeu
	<p>Juego de pinzas regulables <b>SV-2</b>                      SV-2 Adjustable clamps set                      Jeu pinces réglables SV-2</p> <p>90kg  SV-2</p>		00 60 58		1 juego 1 set 1 jeu
	<p>Juego de pinzas <b>SV-EASY</b>                      SV-EASY clamps set                      Jeu pinces SV-EASY</p> <p>90kg  SV-EASY</p>		00 68 58		1 juego 1 set 1 jeu
	<p>Freno retenedor <b>SV-A60 / SV-A90</b>                      SV-A60 / SV-A90 Retaining brake                      Frein de retenue SV-A60 / SV-A90</p>		00 66 57		25 piezas 25 pièces 25 pièces
	<p>Freno retenedor <b>SV-P70</b>                      SV-P70 retaining brake                      Frein de retenue SV-P70</p>		00 72 19		25 piezas 25 pièces 25 pièces



## Componentes

### Components | Composants

ACCESORIOS   ACCESSORIES   ACCESSOIRES		Acabado	Cód.		
	<p>Guiador inferior plástico para vidrio de 8-12mm Plastic bottom guide for glass of 8-12mm Guide inférieur plastique pour verre de 8-12mm</p>		00 40 57		25 piezas 25 pieces 25 pièces
	<p>Soporte superior separador, montaje a pared Separator top support, wall mounting Support supérieur séparateur, fixation à mur</p> <p>  STANDARD EXCELLENCE</p>	<b>S</b>	00 63 03*	0,1 m	1 pieza 1 piece 1 pièce
	<p>Embellecedor final para perfil superior Standard Final trim for Standard top track Capuchon final pour rail Standard</p>		00 80 57		25 piezas 25 pieces 25 pièces
	<p>Soporte pared escuadra Wall fixing bracket Support équerre pour fixation à mur</p> <p>29mm</p>		00 60 54*		25 piezas 25 pieces 25 pièces
	<p>Soporte pared escuadra Wall fixing bracket Support équerre pour fixation à mur</p> <p>32,5mm</p>		00 60 59 <sup>1</sup>		25 piezas 25 pieces 25 pièces
	<p>Tornillería para perfil FTI. 1 puerta de madera y/o de cristal Screws for FTI track. 1 wooden and/or glass door Vis pour profil FTI. 1 porte bois et/ou verre</p> <p>M8x50</p>		00 72 70		1 juego 1 set 1 jeux

<sup>1</sup>Para las familias que incorporen soporte pared con perfilera de 2 m, 3 m o 5 m, aplicar uno por cada taladro | <sup>1</sup>For sets that incorporate a wall support with 2m, 3m, 5m or 6m profiling, apply one for each drill hole | <sup>1</sup>Pour les familles intégrant un support mural avec huisserie de 2m, 3m, 5m ou 6m, appliquer un support pour chaque trou percé.

2 m ..... 10 soportes pared | supports wall | supports muraux  
3 m ..... 15 soportes pared | supports wall | supports muraux  
5 m ..... 25 soportes pared | supports wall | supports muraux

**Componentes**

Components | Composants

KITS   KITS   KITS		Acabado	Cód.		
 <p>x1 x1</p>	<p>Boxed kit <b>SV-P70 EASY</b> guía <b>STANDARD</b>  <b>x2 freno retenedor</b>                      Boxed kit SV-P70 EASY STANDARD top track.                      x2 retaining stopper                      Boxed kit SV-P70 EASY rail supérieur STANDARD.                      x2 frein de retenue</p> <p><b>70kg</b> </p> <p>33x33mm</p>	<b>S</b>	0 981 74	2 m	1 kit
 <p>x1 x1</p> <p>x1 2m x1 10mm</p>	<p>Boxed kit <b>SV-P70 EASY</b> guía <b>STAR</b> x1 <b>SofTop Doble</b>                      Boxed kit SV-P70 EASY top track STAR x1 SofTop Double                      Boxed kit SV-P70 EASY rail supérieur STAR x1 SofTop Double</p> <p><b>70kg</b> </p> <p>33x32mm</p>	<b>S</b>	0 980 04	2 m	1 kit
 <p>x1 x1</p>	<p>Boxed kit <b>SV-P70</b> Conjunto <b>FUNDA FT + STAR</b>  <b>x1 SofTop Doble</b>                      Boxed kit SV-P70 Support FT + STAR. x1 SofTop Double                      Boxed kit SV-P70 Jeu rail de couverture FT + STAR.                      x1 SofTop Double</p> <p><b>70kg</b> <b>Pocket</b></p> <p>FUNDA FT + STAR</p>	<b>S</b>	0 980 05	2 m	1 kit
	<p>Kit <b>SV-P70 EASY</b>. Perfil superior <b>EXCELLENCE + FRAME FLAT</b>. <b>x2 Freno retenedor</b>                      SV-P70 EASY Kit .EXCELLENCE + FRAME FLAT top track.                      x2 Retaining stopper                      Kit SV-P70 EASY. Rail supérieur EXCELLENCE + FRAME FLAT. x2 Frein de retenue.</p> <p><b>70kg</b> </p> <p>33x33mm</p>	<b>BL</b>	0 981 77	2 m	1 kit

\*Perfilería Flat Frame: perfil perimetral 2ux3m + división interna 2u x 3m  
 Flat Frame Profiles: Perimeter profile 2ux3m + internal division 2 units x 3m  
 Profilés Flat Frame : profil périmétral 2ux3m + division interne 2 unités x 3m

# ESSENTIAL GLASS + FRAME FLAT

SV-P70



- 1 **GUÍA EXCELLENCE** de 2m en aluminio natural.
- 2 **JUEGO DE ACCESORIOS SV-P70 EASY** para 70Kg con doble freno retenedor. Con roldanas con rodamiento a bolas para un deslizamiento suave y silencioso y pinza Easy, caracterizada por su reducido tamaño y por su facilidad de montaje gracias a que permite la instalación frontalmente. | SV-P70 EASY ACCESSORIES SET for 70kg with double retaining brake. With ball-bearing rollers for smooth and silent sliding and Easy clamp, characterized by its small size and easy installation as it allows frontal installation. | Kit d'accessoires SV-P70 EASY pour 70 kg avec double frein de retenue. Avec des roulettes à roulement à billes pour un coulisement fluide et silencieux et un Easy Clamp, caractérisé par sa petite taille et son installation facile, permettant une installation frontale.
- 3 **TAPETA EMBELLECEDORA** preparada para hacer clipaje sobre el perfil de 2m, en acabado aluminio lacado negro. | 2m PELMET COVER clipped on to the top track, in black lacquered aluminum finish (80mm). | Couvre-corniche de 2m clipsé sur le rail supérieur, en aluminium laqué noir (80 mm).
- 4 **FRAME FLAT**: perfilería embellecedora en formato pletina de aluminio que dará un look chic industrial a la instalación. Fácil instalación ya que se pega en el cristal y se suministra con cinta de doble cara 3M. | Decorative aluminum strip profiles that give an industrial look to the installation. Easy installation as it is stuck to the glass and supplied with 3M double-sided adhesive tape. | Profilés décoratifs en aluminium qui donnent un aspect industriel à l'installation. Installation facile, car ils se collent sur le verre et sont fournis avec un ruban adhésif double-face 3M.

- Perfil perimetral para enmarcar grosores de vidrio de 10mm | U Channel for perimeter framing, for 10mm glass. | Profilé en U pour encadrement périmétrique, pour verre de 10 mm.

- Perfil división interna para crear infinidad de diseños | Flat profile for internal grids. | Profilé plat pour grilles intérieures.

- 5 **TAPAS LATERALES EASY**. Montaje a pared. Piezas fabricadas en aluminio lacado negro. | LATERAL END CAPS. Wall mounting. In matt black lacquered aluminum. | Capuchons latéraux. Fixation murale. En aluminium laqué noir mat.
- 6 **GUIADOR INFERIOR FRAME FLAT** en aluminio lacado negro. | FRAME FLAT BOTTOM GUIDE in matt black lacquered aluminum. | Guide inférieur à cadre plat en aluminium laqué noir mat.

## CONTENIDO DEL KIT | KIT CONTENT | CONTENU DU KIT

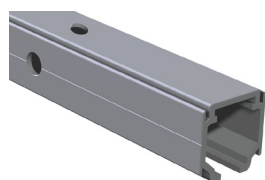

1

x1 Perfil superior | Top track | Rail supérieur **EXCELLENCE**. | Montaje a pared | Wall mounting | Fixation à mur | 2m

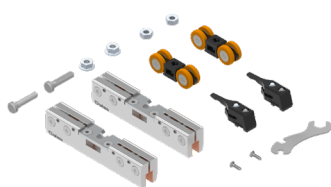

2

x1 Juego de accesorios | Fitting set | Garniture **SV-P70 EASY** x2 Freno retenedor | Retaining stopper | Frein de retenue

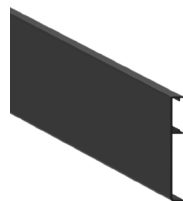

3

x1 Tapeta para pinza | Clamp pelmet cover | Cache-pince **EASY** | 2m

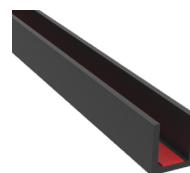

4

x2 Perfil perimetral | Perimeter track | Rail périmétrique **FRAME FLAT** 10mm. 3m<sup>1</sup>



4

x2 Perfil división interna | Internal division track | Rail de division intérieure **FRAME FLAT**. 3m<sup>1</sup>

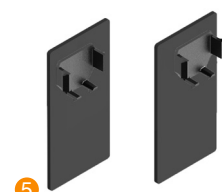

5

x1 Juego de tapas | Lateral cap set | Jeu capuchons latéraux **EASY**. Montaje a pared. | Wall mounting | Fixation à mur



6

x1 Guiador inferior | Bottom guide | Guide inférieur **FRAME FLAT**.

Acabado	Código
● BL	0 981 77

● **BL** | Aluminio lacado negro mate | Matt black lacquered aluminium | Aluminium laqué noir mat

<sup>1</sup> También se venden por separado en acabado lacado blanco y negro | Also sold separately in white and black lacquered finishes. | Également vendu séparément avec des finitions laquées blanche et noire.

# Essential Glass XL

SV-A110 | SV-P140 | SV-A160

# ESSENTIAL GLASS XL



BIBLIOTECA DE DESCARGAS



DOWNLOADS LIBRARY | BIBLIOTHÈQUE TÉLÉCHARGEMENTS

## ES

1. Instalación a pared, techo, falso techo o entre paredes para la ocultación máxima de los herrajes. 2. **Pinza Easy XL**, de fácil instalación y estética minimalista gracias a su reducida tapeta embellecedora. 3. **Perfil Funda FT XL** (falso techo / entre paredes) para guía extraíble que posibilita la instalación por fases. Permite el acceso directo a los herrajes, pudiendo instalar y desmontar en cualquier momento; ya sea para actualizar componentes adicionales o para reemplazarlos sin necesidad de realizar modificaciones en el falso techo. 4. **Perfil STAR FTI XL** (Falso Techo Invisible): que queda totalmente oculto en el techo y con posibilidad de **Registro STAR FTI XL**: pequeño acceso invisible compatible con juegos sin SofTop que permite montar y desmontar los herrajes sin dañar el techo. 5. Perfil separador con geometría pensada para ahorrar tiempo en la instalación. 6. **Ausencia de perfil inferior** (opcional) para crear zonas de paso libres de obstáculos. 7. Perfilera en acabados aluminio anodizado plata y lacado negro y blanco para su mejor adaptación a las exigencias arquitectónicas. 8. Solución para paneles de hasta 160 Kg. 9. **Distintas opciones de rodamiento**: a fricción o a bolas, ambas silenciosas y con un mínimo de esfuerzo de deslizamiento. 10. Como opciones de frenado: **SofTop doble** para una detención de cierre y apertura lineal, suave y sin impactos **para hojas de hasta 140 Kg** o con freno retenedor. 11. No se requiere mecanización del vidrio en ninguna de las aplicaciones. 12. Certificado de calidad Applus según normativa EN 1527. Grado de Durabilidad 6: 100.000 ciclos de ensayo y Grado de Corrosión 4: 240h.

## EN

1. Wall, ceiling mount, false ceiling or between walls installation 2. Easy XL clamp, easy to install and minimalist aesthetics thanks to its small trim strip. 3. **Support FT XL track** (false ceiling/between walls), allowing to remove the sliding top track, making possible installation in phases. It also provides direct access to the mechanisms, to install and disassemble at any stage, even after construction for maintenance, either to incorporate additional components or to replace them, without the need to make modifications to the false ceiling or walls. 4. **STAR FTI XL** (Invisible False Ceiling): fully hidden in the ceiling with the option of **STAR FTI XL register**: small, invisible access compatible with systems without SofTop, allowing fittings to be mounted and dismantled without damaging the ceiling. 5. Separator wall mounting track designed to optimize and reduce installation time. 6. **Absence of a bottom track** (optional) to create passage areas free of obstacles. 7. Profiles and accessories available in matte silver anodized aluminum, lacquered black, and matte white finishes. 8. Solution for panels up to 160 kg. 9. **Various rolling options**: friction or ball bearing, both silent and effortless sliding. 10. **Double Soft Top** (retaining brake) up to 140Kg for a linear, soft and impact-free closing and opening, extending the product's lifespan. 11. No machining of the glass is required for any of the applications. 12. Applus+ certified according to EN 1527 standard for the entire product line. Durability Grade 6: 100.000 test cycles, and Corrosion Grade 4: 240 hours.

## FR

1. Installation au mur ou au plafond, ou au faux plafond, ou entre les murs plafond pour dissimuler au maximum la quincaillerie. 2. **Pince Easy XL**, facile à installer et esthétique minimaliste grâce à son petit cache enjoliveur. 3. **Rail de couverture FT XL** (faux plafond / entre les murs) pour guide amovible qui permet une installation par phases. Il permet un accès direct à la quincaillerie et peut être installé et retiré à tout moment, soit pour mettre à niveau des composants supplémentaires, soit pour les remplacer sans qu'il soit nécessaire d'effectuer des modifications au faux plafond. 4. **Profil STAR FTI XL** (Faux Plafond Invisible) : totalement caché dans le plafond avec la possibilité d'un registre **STAR FTI XL**: petit accès invisible compatible avec les systèmes sans SofTop, permettant de monter et démonter les ferrures sans endommager le plafond. 5. Profilé d'écartement dont la géométrie est conçue pour gagner du temps d'installation. 6. **Pas de profilé inférieur** (en option) pour créer des zones de passage sans obstacles. 7. Profilés avec finitions en aluminium anodisé argent et laqué noir et blanc pour une meilleure adaptation aux exigences architecturales. 8. Solution pour les panneaux jusqu'à 160kg. 9. **Différentes options de roulements**: à friction ou à billes, tous deux silencieux et avec un effort de glissement minimal. 10. Comme options de freinage: **Double SofTop** pour des arrêts de fermeture et d'ouverture linéaires, en douceur et sans impact pour des vantaux **jusqu'à 140 kg** ou avec frein de rétention. 11. Aucune mécanisation du verre n'est requise sur aucune des applications. 12. Certificat de qualité Applus conforme à la norme EN 1527. Grade de Durabilité 6: 100 000 cycles de test, et Grade de Corrosion 4: 240 heures.

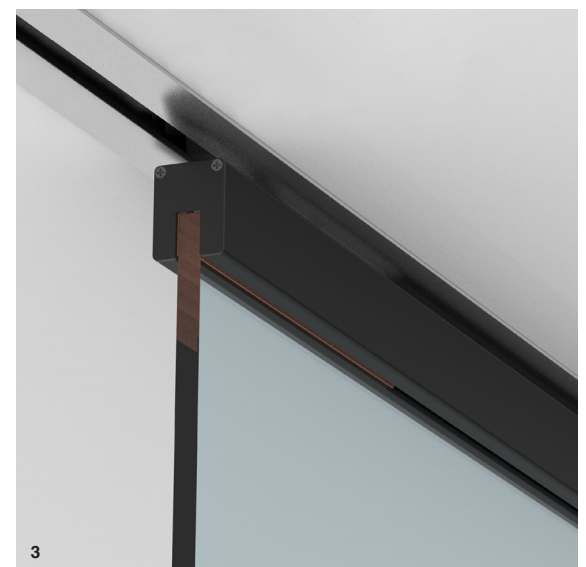
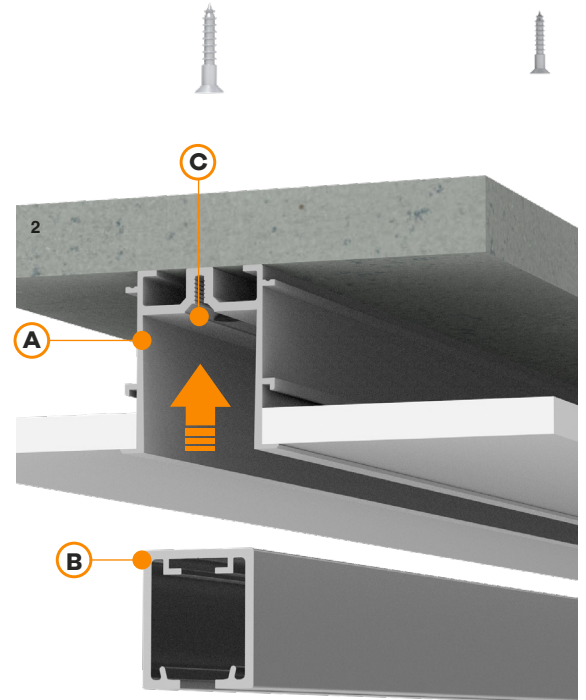
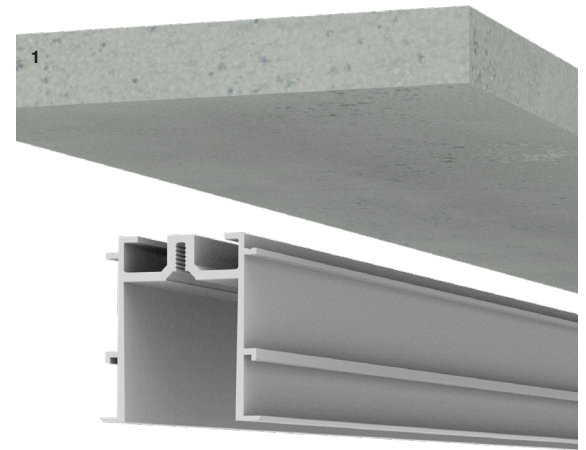

**A** Perfil funda FT XL | Support FT XL track | Rail de couverture FT XL. **B** Perfil Star XL | Star XL track | Rail Star XL. **C** Diseño de perfil con avellanado integrado | Track design with drilled countersink | Conception de rail avec fraisage intégré.

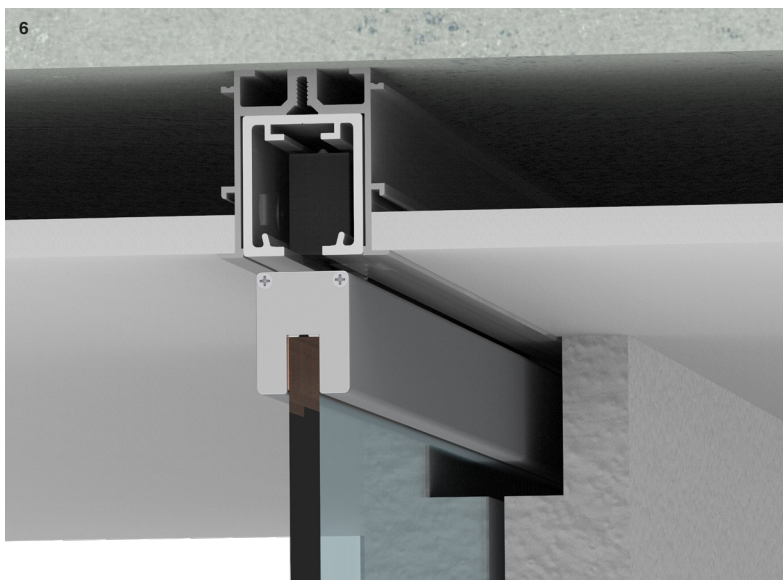
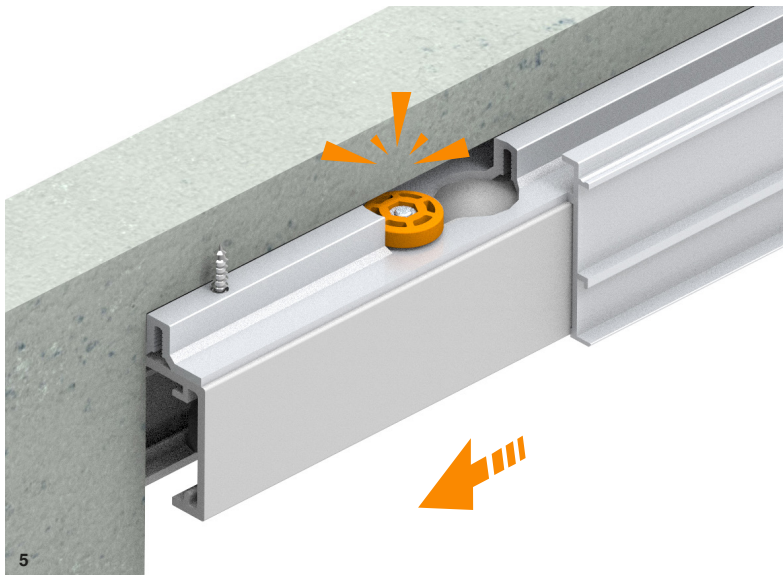
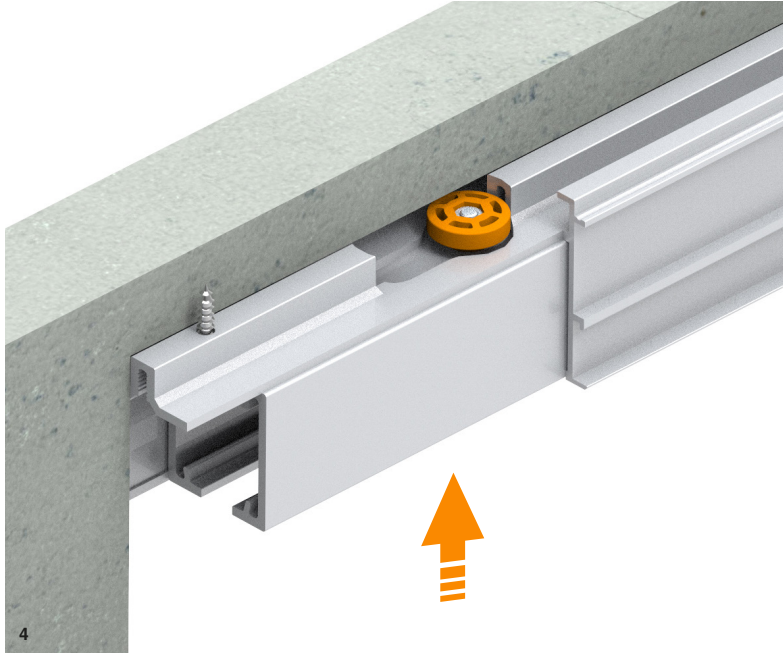

**1, 2 y 3** Conjunto perfil Funda FT XL + Perfil Star XL, montaje a falso techo | Support FT XL + Star XL track set, false ceiling mounting | Ensemble Rail de couverture FT XL + Star XL, fixation a faux-plafond. **4, 5 y 6** Conjunto perfil Funda FT XL + Perfil Star XL, montaje entre paredes | Support FT XL + Star XL track set, mounting between walls | Ensemble Rail de couverture FT XL + Star XL, fixation entre les murs.

## Características técnicas

Technical characteristics | Caractéristiques techniques

### Perfilería Profiles | Profils

<b>STANDARD XL</b>  39x41 mm No SofTop	<b>EXCELLENCE XL</b>  40x46 mm REGISTRO   REGISTER   REGISTRE STAR FTI XL	<b>STAR XL</b>  40x46 mm	<b>STAR XL VF</b>  59x46 mm
<b>STAR FTI XL</b>  61x55mm	<b>SEPARADOR   SEPARATOR   SÉPARATEUR STAR XL / EXCELLENCE XL</b>  49x60 mm	<b>FUNDA   SUPPORT   COUVERTURE FT XL</b>  61x57 mm	<b>CONJUNTO   SET   JEU</b> <b>FUNDA   SUPPORT   COUVERTURE FT XL + STAR XL</b>  61x57 mm
 17x12 mm	 20x20 mm	 21x20 mm	 20x15 mm

### Especificaciones Specifications | Spécification

 8-10-12 mm	 16-20 mm	 MÍN. 600 mm	 SV-P140 EASY <b>SofTop doble</b> MÍN. 750 mm
 <b>SofTop</b> MÁX. 140Kg	 RODAMIENTO A BOLAS BALL BEARING ROULEMENT À BILLES		

### Peso Weight | Poids

110 kg	243 lb
140 kg	309 lb
160 kg	353 lb

VIDEO | VIDEO | VIDÉO



### Producto certificado

Certificat product | Produit certifié



Grado de Durabilidad 6: 100.000 ciclos de ensayo y Grado de Corrosión 4: 240h. | Durability Grade 6: 100,000 test cycles, and Corrosion Grade 4: 240h. Grade de Durabilité 6: 100 000 cycles de test, et Grade de Corrosion 4: 240 heures.

MONTAJE ENTRE PAREDES | MOUNTING BETWEEN WALLS | FIXATION ENTRE LES MURS

## Instalación

Installation | installation

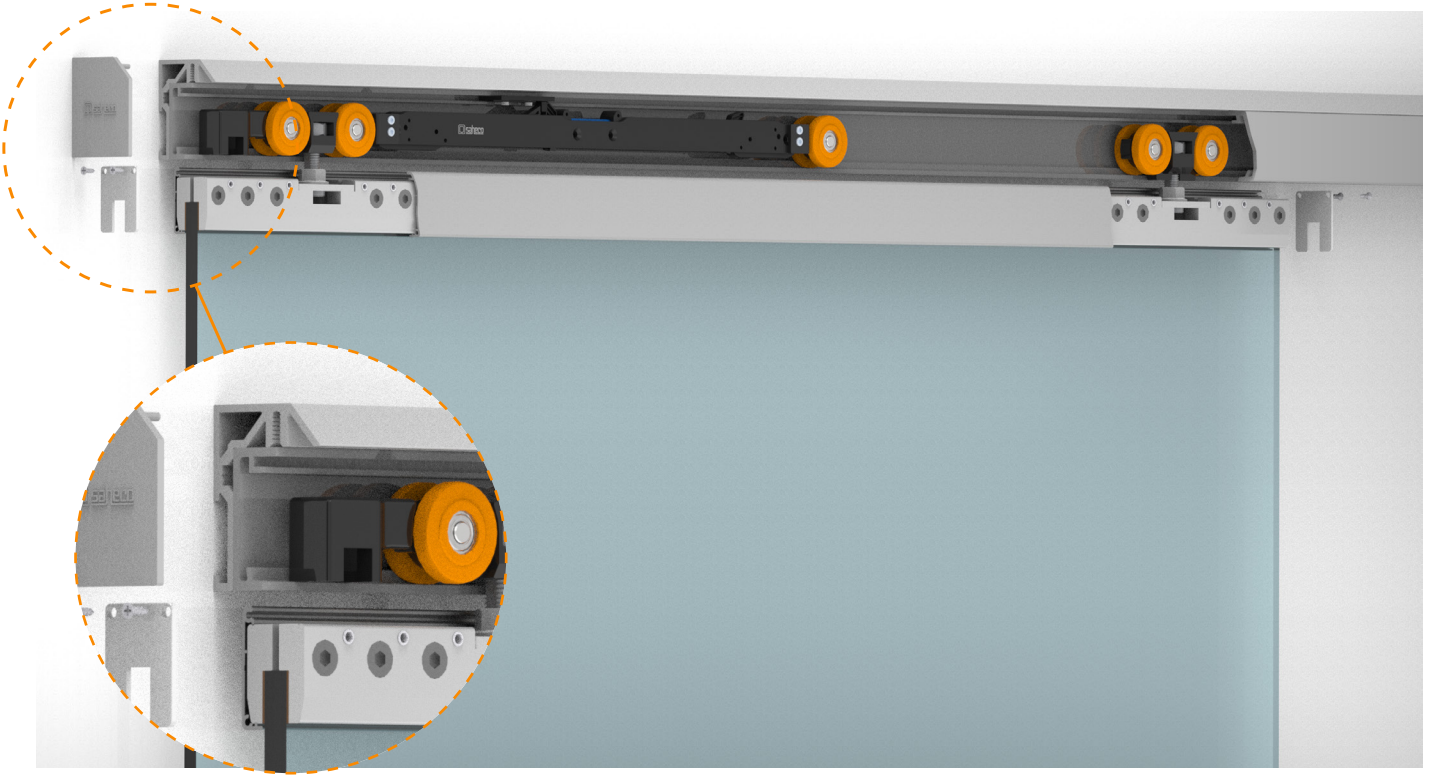

1



2



3

**1 y 2** Perfil separador XL+ perfil Star XL con juego de accesorios SV-P140 + Pinza y tapeta EASY XL. x1 SofTop doble | Separator XL track + Star XL track with SV-P140 fitting set + EASY XL clamp and cover. x1 double SofTop | Rail séparateur XL+ rail Star XL avec garniture SV-P140 + pince et cache EASY XL. x1 double SofTop. **3.** Perfil Excellence XL atornillado directamente a pared, con tapeta y juego de accesorios SV-A160. | Excellence XL track screwed directly to the wall with pelmet cover and SV-A160 fitting set. | Rail Excellence XL vissé directement au mur avec cache et garniture SV-A160.

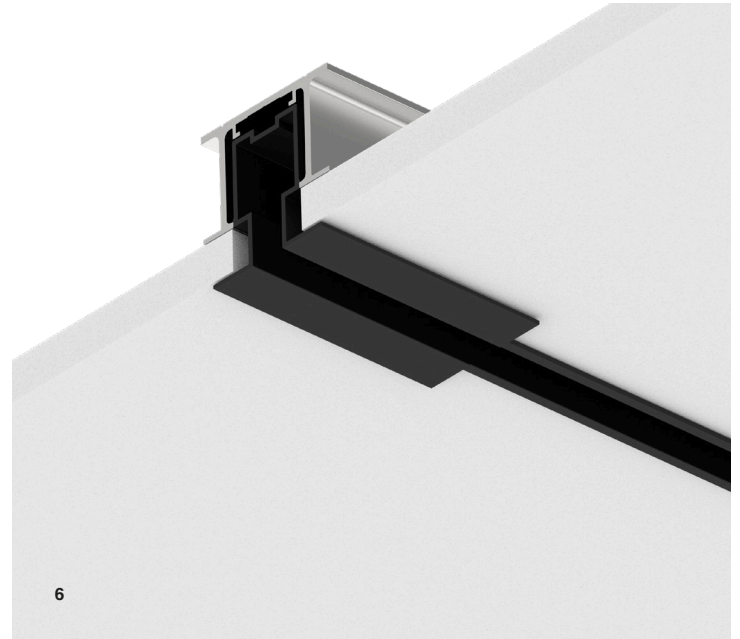
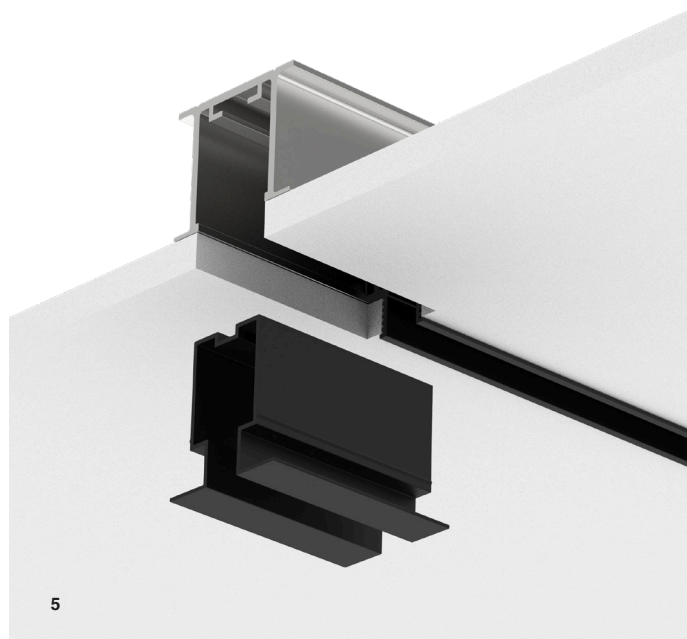
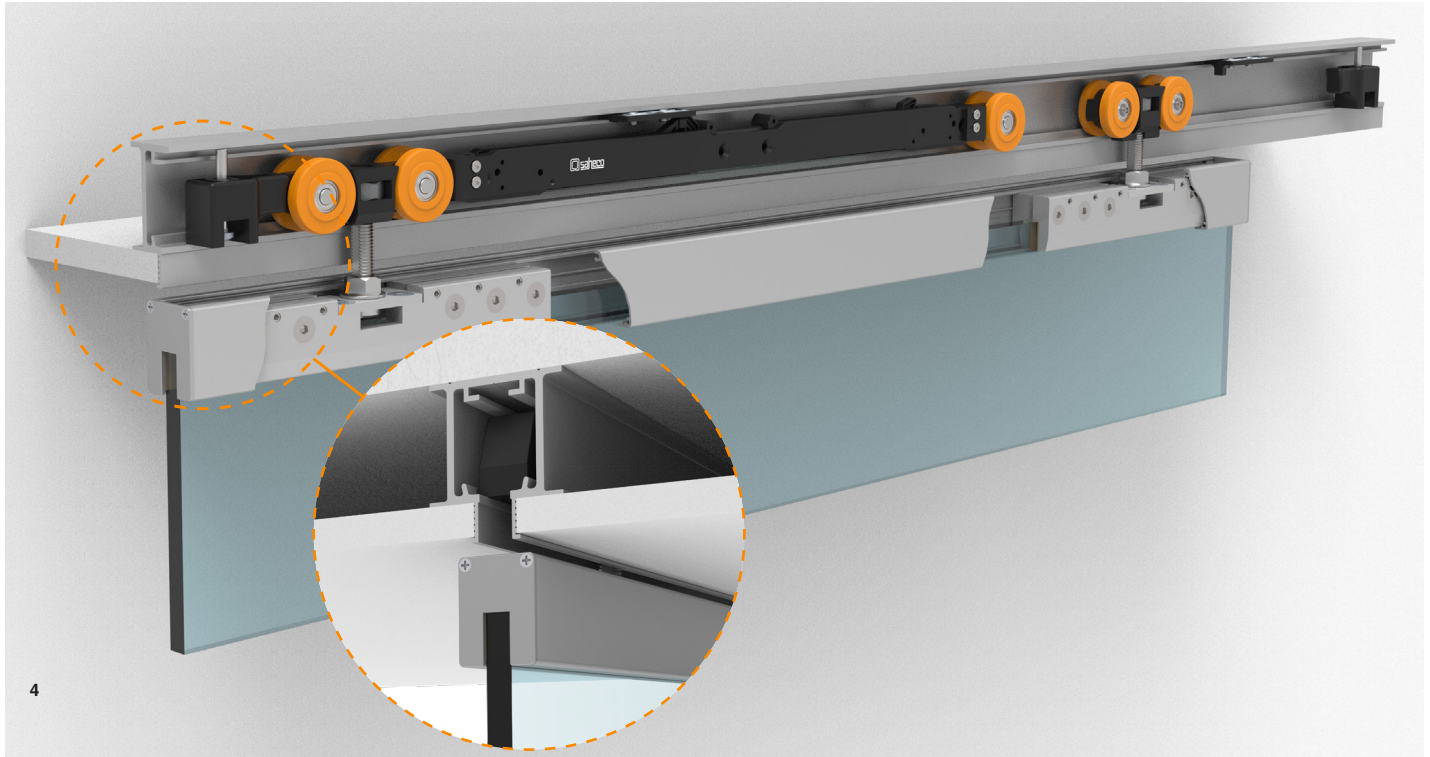

**4** Perfil FTI XL (Falso Techo Invisible) con juego de accesorios SV-P140 x1 SofTop doble | FTI XL Track (invisible false ceiling) with fitting set SV-P140 x1 double SofTop | Rail FTI XL (faux plafond invisible) avec garniture SV-P140 x1 double SofTop **5 y 6** Registro STAR FTI XL (para perfil FTI XL) | STAR FTI XL Register (for FTI XL profile) | Registre STAR FTI XL (pour profil FTI XL).

**Variantes de instalación**

Installation possibilities | Variantes d'installation

**PARED**  
WALL  
MUR

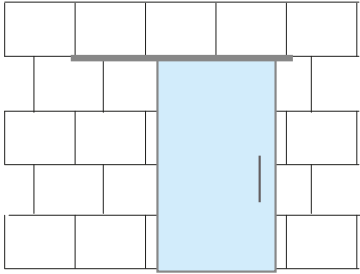

**PARED CON VIDRIO FJO**  
WALL WITH FIXED PANEL  
MUR AVEC VERRE FIXE

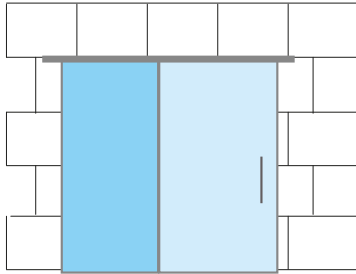

**TECHO**  
CEILING  
PLAFOND

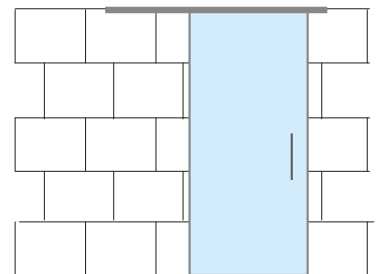

**TECHO CON VIDRIO FIJO**  
CEILING WITH FIXED PANEL  
PLAFOND AVEC VERRE FIXE

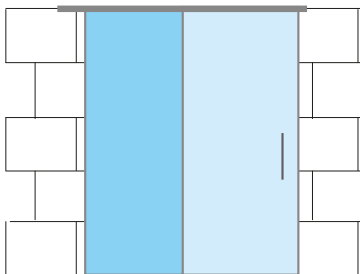

**FALSO TECHO**  
FALSE CEILING  
FAUX PLAFOND

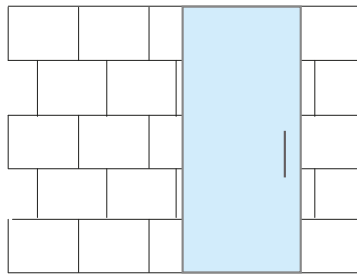

**FALSO TECHO CON VIDRIO FIJO**  
FALSE CEILING WITH FIXED PANEL  
FAUX PLAFOND AVEC VERRE FIXE

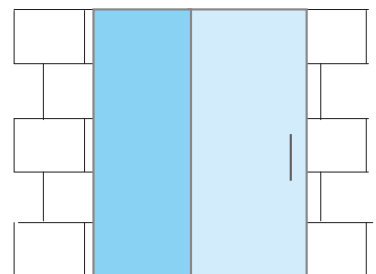

**ENTRE PAREDES**  
BETWEEN WALLS  
ENTRE MURS

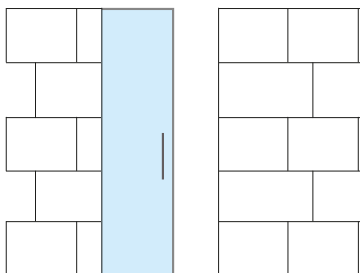

**FALSO TECHO INVISIBLE** |  
INVISIBLE FALSE CEILING |  
FAUX-PLAFOND INVISIBLE

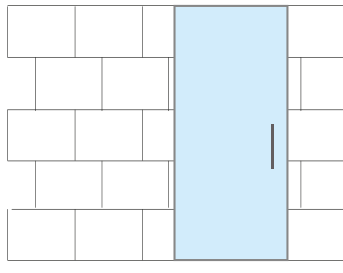

 **PUERTA CORREDERA** | SLIDING DOOR | PORTE COULISSANTE

 **VIDRIO FIJO** | FIXED GLASS | VERRE FIXE



## Sección tipo

Cross-section | Section type (Cotas en mm | Dimensions in mm | Dimensions en mm)

### MONTAJE A PARED | WALL MOUNTING | FIXATION À MUR

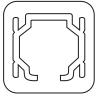

STANDARD XL  
No SoftTop



STAR XL



STAR XL + SEPARADOR

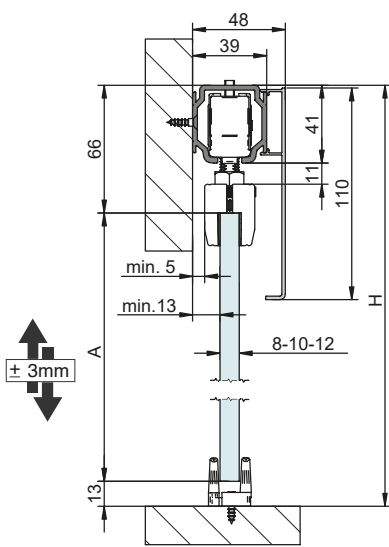

STANDARD XL  
A= H-79

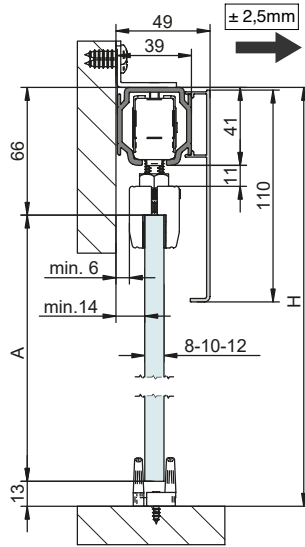

STANDARD XL  
A= H-79

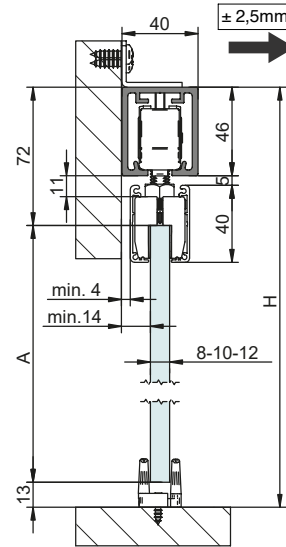

STAR XL  
A= H-85  
F= H-47

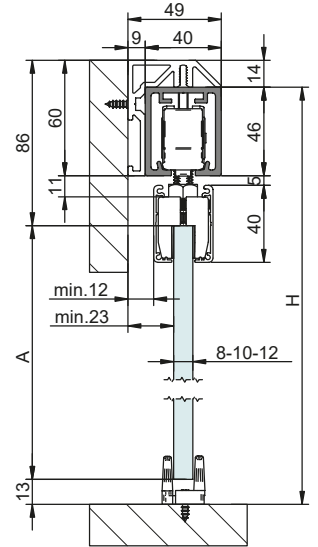

STAR XL + SEPARADOR |  
SEPARATOR | SÉPARATEUR  
A= H-85  
F= H-47

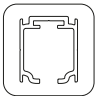

EXCELLENCE XL

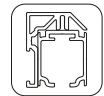

EXCELLENCE XL +  
SEPARADOR

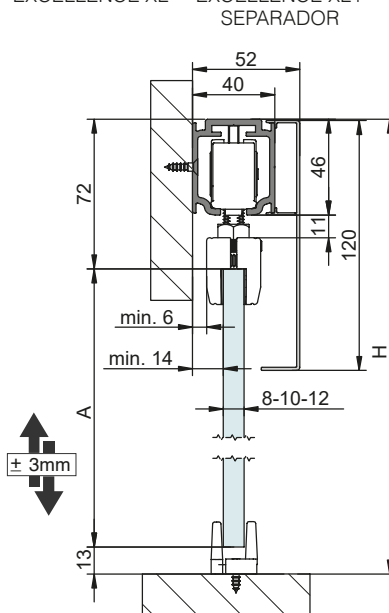

EXCELLENCE XL  
A= H-85

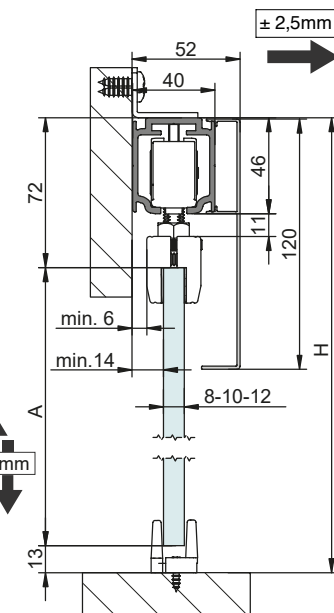

EXCELLENCE XL  
A= H-85

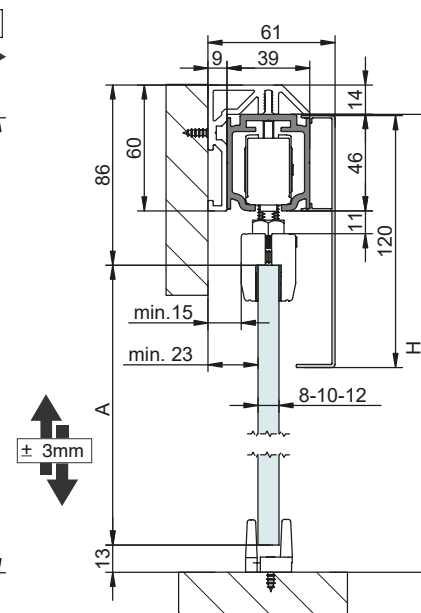

EXCELLENCE XL + SEPARADOR |  
SEPARATOR | SÉPARATEUR  
A= H-85

**Sección tipo**

Cross-section | Section type (Cotas en mm | Dimensions in mm | Dimensions en mm)

**MONTAJE A TECHO | CEILING MOUNTING | FIXATION À PLAFOND**



STANDARD XL  
NO SOFTOP



EXCELLENCE XL

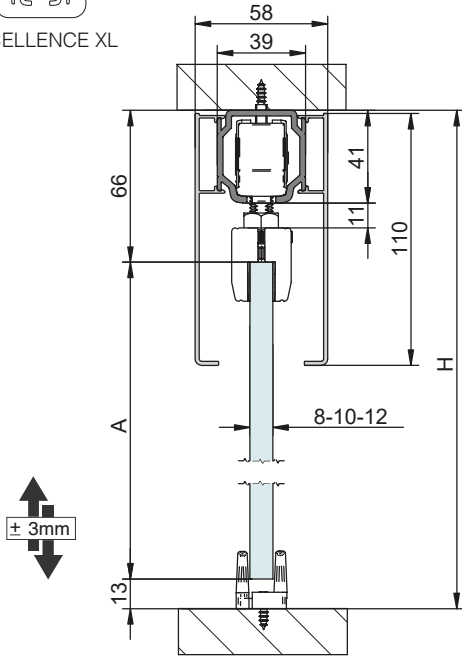

STANDARD XL

$A = H - 79$

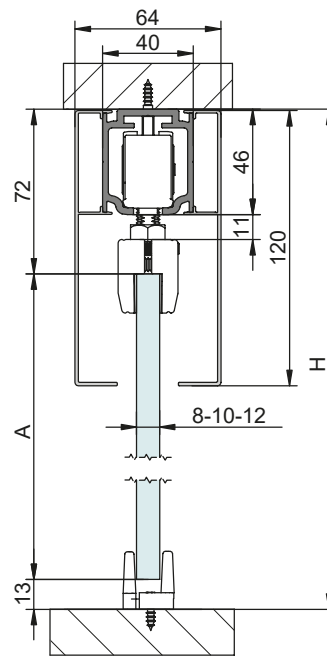

EXCELLENCE XL

$A = H - 85$



STAR XL



STAR XL  
VIDRIO FIJO

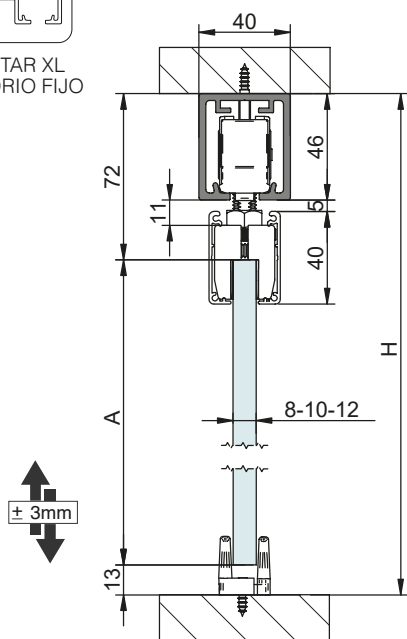

STAR XL

$A = H - 85$

$F = H - 47$

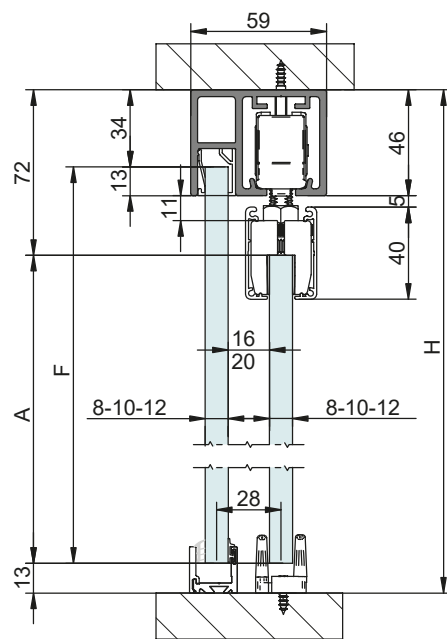

STAR XL + VIDRIO FIJO |  
FIXED GLASS | VERRE FIXE

$A = H - 85$

$F = H - 47$



Sección tipo

Cross-section | Section type (Cotas en mm | Dimensions in mm | Dimensions en mm)

MONTAJE A FALSO TECHO | FALSE CEILING MOUNTING | FIXATION À FAUX-PLAFOND/PLAFOND



STAR FT XL

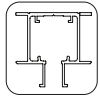

STAR FTI XL

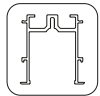

FUNDA FT

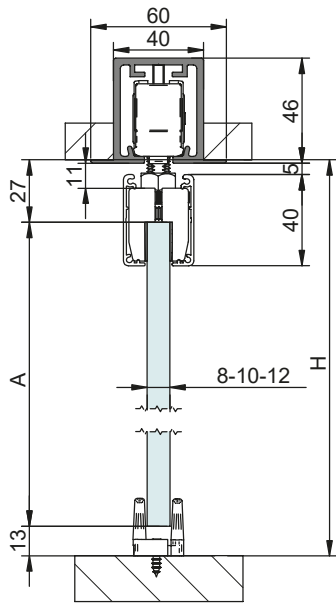

STAR FT XL

$A = H - 40$

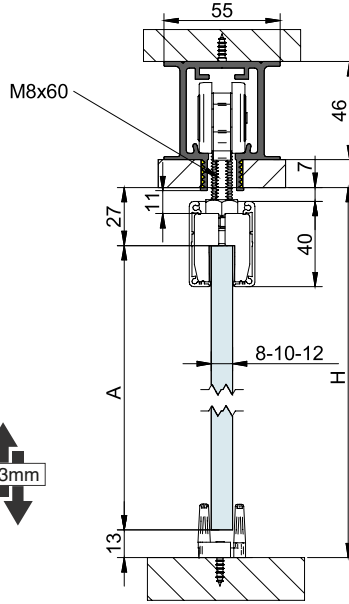

STAR FTI XL

$A = H - 40$

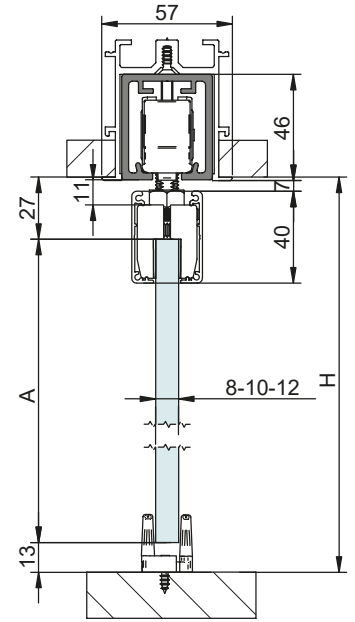

FUNDA | SUPPORT |  
COUVERTURE FT

$A = H - 40$

MONTAJE ENTRE PAREDES | MOUNTING BETWEEN WALLS | FIXATION ET ENTRE LES MURS



CONJUNTO | SET | JEU  
FUNDA | SUPPORT |  
COUVERTURE FT XL + STAR XL

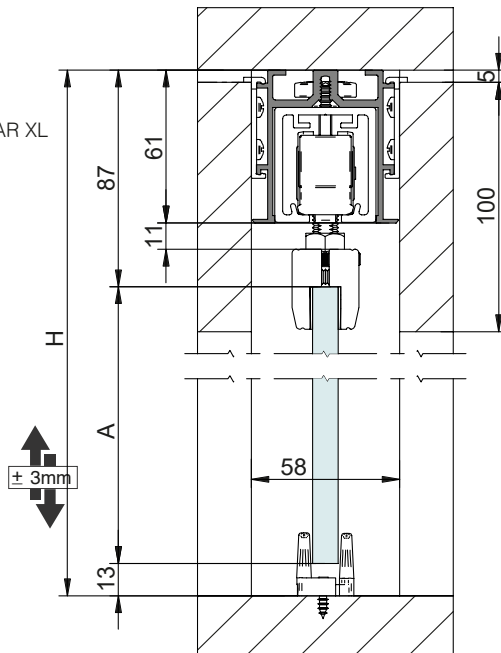

$A = H - 100$

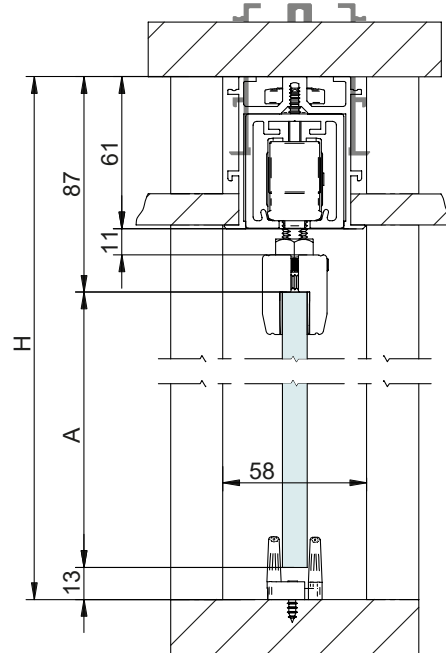

$A = H - 100$

**Componentes**

Components | Composants

PERFILERÍA   PROFILES   PROFILS		Acabado	Cód.	المساحة	
	<p>Perfil superior <b>Standard XL</b>. Montaje a techo Standard XL top track. Ceiling mounting Rail supérieur Standard XL. Fixation à plafond</p> <p>160kg  39x41 mm No SofTop</p>	<b>S</b>	0 126 20 0 126 30 0 126 50	2 m 3 m 5 m	2 perfiles 2 profiles 2 profils
		<b>MF</b>	0 126 21 0 126 31 0 126 51	2 m 3 m 5 m	
	<p>Perfil superior <b>Standard XL</b>. Montaje a techo/pared Standard XL top track. Ceiling/wall mounting Rail supérieur Standard XL. Fixation à plafond/mur</p> <p>160kg  39x41 mm No SofTop</p>	<b>S</b>	0 126 23 0 126 33 0 126 53	2 m 3 m 5 m	2 perfiles 2 profiles 2 profils
		<b>MF</b>	0 126 24 0 126 34 0 126 54	2 m 3 m 5 m	
	<p>Perfil superior <b>Excellence XL</b>. Montaje a techo Excellence XL top track. Ceiling mounting Rail supérieur Excellence XL. Fixation à plafond</p> <p>160kg  40x46 mm</p>	<b>S</b>	0 160 24 0 160 34 0 160 44 0 160 64	2 m 3 m 4 m 6 m	2 perfiles 2 profiles 2 profils
		<b>MF</b>	0 160 25 0 160 35 0 160 45 0 160 65	2 m 3 m 4 m 6 m	
	<p>Perfil superior <b>Excellence XL</b>. Montaje a techo/pared Excellence XL top track. Ceiling/wall mounting Rail supérieur Excellence XL. Fixation à plafond/mur</p> <p>160kg  40x46 mm</p>	<b>S</b>	0 160 29 0 160 39 0 160 49 0 160 69	2 m 3 m 4 m 6 m	2 perfiles 2 profiles 2 profils
		<b>MF</b>	0 161 29 0 161 39 0 161 49 0 161 69	2 m 3 m 4 m 6 m	
	<p>Perfil superior <b>Star XL</b> Montaje a techo Star XL top track. Ceiling mounting Rail supérieur Star XL. Fixation à plafond</p> <p>160kg  40x46 mm</p>	<b>S</b>	0 160 26 0 160 36 0 160 46 0 160 66	2 m 3 m 4 m 6 m	2 perfiles 2 profiles 2 profils
		<b>BL</b>	0 160 27 0 160 37 0 160 47 0 160 67	2 m 3 m 4 m 6 m	
	<p>Perfil superior <b>Star XL</b> para vidrio fijo Star XL top track for fixed glass Rail supérieur Star XL pour verre fixe</p> <p>160kg  59x46 mm</p>	<b>S</b>	0 162 23 0 162 33 0 162 43 0 162 63	2 m 3 m 4 m 6 m	2 perfiles 2 profiles 2 profils
		<b>BL</b>	0 162 24 0 162 34 0 162 44 0 162 64	2 m 3 m 4 m 6 m	
		<b>WL</b>	0 162 25 0 162 35 0 162 45 0 162 65	2 m 3 m 4 m 6 m	

**S** Aluminio anodizado plata mate  
Satin anodized aluminium  
Aluminium anodisé argent

**MF** Aluminio natural  
Mill finish aluminium  
Aluminium brut





**BL** Aluminio lacado negro  
Black lacquered aluminium  
Aluminium anodisé laqué noir

**WL** Aluminio lacado blanco  
White lacquered aluminium  
Aluminium anodisé laqué blanc

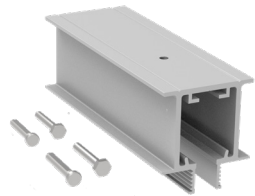

Componentes

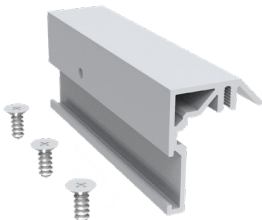
Components | Composants

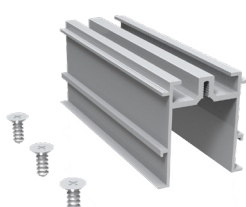
PERFILERÍA   PROFILES   PROFILS		Acabado	Cód.								
	Embellecedor para perfil superior <b>STAR XL</b> para vidrio fijo STAR XL trim for fixed glass groove Rail de recouvrement STAR XL pour rail avec panneau fixe  16x21 mm	<b>S</b>	00 81 74	3 m	1 perfil 1 profile 1 profil						
		<b>BL</b>	00 81 73	3 m							
		<b>WL</b>	00 81 72	3 m							
 M10x60	Perfil <b>Star FTI XL</b> . Star FTI XL top track. Rail supérieur Star FTI XL.  160kg 61x55mm	<b>S</b>	0 163 23 0 163 33 0 163 43 0 163 63	2 m 3 m 4 m 6 m	2 perfiles 2 profiles 2 profils						
		<b>BL</b>	0 163 24 0 163 34 0 163 44 0 163 64	2 m 3 m 4 m 6 m							
		<b>WL</b>	0 163 25 0 163 35 0 163 45 0 163 65	2 m 3 m 4 m 6 m							
		 NEW	<b>Registro Star FTI XL</b> . Montaje a falso techo invisible Star FTI XL register. Invisible false ceiling mounting Registre Star FTI XL. Fixation à faux-plafond invisible  160kg 61x55mm No SofTop	<b>S</b>		0 163 13	75 mm	1 perfil 1 profile 1 profil			
				<b>BL</b>		0 163 14	75 mm				
				<b>WL</b>		0 163 15	75 mm				
						Perfil superior <b>Star FT XL</b> . Montaje a falso techo Star FT XL top track. False ceiling mounting Rail supérieur Star FT XL. Fixation à faux-plafond  160kg 60x46 mm	<b>S</b>		0 161 26 0 161 36 0 161 46 0 161 66	2 m 3 m 4 m 6 m	2 perfiles 2 profiles 2 profils
							<b>BL</b>		0 161 27 0 161 37 0 161 47 0 161 67	2 m 3 m 4 m 6 m	
							<b>WL</b>		0 161 28 0 161 38 0 161 48 0 161 68	2 m 3 m 4 m 6 m	
	Perfil superior <b>Separador Excellence XL / Star XL</b> . Montaje a pared Excellence XL / Star XL top Separator track. Wall mounting Rail supérieur Séparateur Excellence XL / Star XL. Fixation à mur  160kg 49x60 mm Compatible   Suitable EXCELLENCE XL STAR XL	<b>S</b>	0 162 20 <sup>1</sup> 0 162 30 <sup>1</sup> 0 162 40 <sup>1</sup> 0 162 60 <sup>1</sup>		2 m 3 m 4 m 6 m		1 perfil 1 profile 1 profil				
		<b>BL</b>	0 162 21 <sup>1</sup> 0 162 31 <sup>1</sup> 0 162 41 <sup>1</sup> 0 162 61 <sup>1</sup>		2 m 3 m 4 m 6 m						
		<b>WL</b>	0 162 22 <sup>1</sup> 0 162 32 <sup>1</sup> 0 162 42 <sup>1</sup> 0 162 62 <sup>1</sup>		2 m 3 m 4 m 6 m						
			Perfil <b>Funda FT XL</b> . Montaje a falso techo Support FT XL track. False ceiling mounting Rail de couverture FT XL. Fixation à faux-plafond  160kg 61x57 mm Compatible   Suitable EXCELLENCE XL STAR XL Se sirve sin mecanizar   Is served without machining   Est servi sans usinage	<b>S</b>	0 161 23 <sup>1</sup> 0 161 33 <sup>1</sup> 0 161 43 <sup>1</sup> 0 161 63 <sup>1</sup>	2 m 3 m 4 m 6 m		1 perfil 1 profile 1 profil			
				<b>BL</b>	0 161 24 <sup>1</sup> 0 161 34 <sup>1</sup> 0 161 44 <sup>1</sup> 0 161 64 <sup>1</sup>	2 m 3 m 4 m 6 m					
				<b>WL</b>	0 161 25 <sup>1</sup> 0 161 35 <sup>1</sup> 0 161 45 <sup>1</sup> 0 161 65 <sup>1</sup>	2 m 3 m 4 m 6 m					

<sup>1</sup> Se sirve con tornillería | <sup>1</sup>Served with screws | <sup>1</sup>Servi avec vis. 2 m - 6 tornillos | screw | vis 3 m - 8 tornillos | screw | vis 4 m - 11 tornillos | screw | vis 6 m - 16 tornillos | screw | vis

<sup>2</sup> Se sirve con clip tapeta madera | <sup>2</sup>Served with clip for timber pelmet | <sup>2</sup>Servi avec clip pour cache en bois. 2 y 3 m - 8 clips | clips | clips 4 y 6 m - 12 clips | clips | clips









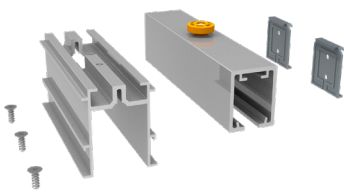

**S** Aluminio anodizado plata mate  
Satin anodized aluminium  
Aluminium anodisé argent

**BL** Aluminio lacado negro  
Black lacquered aluminium  
Aluminium anodisé laqué noir

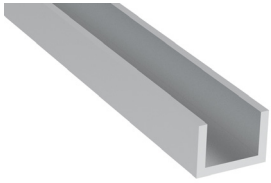
**WL** Aluminio lacado blanco  
White lacquered aluminium  
Aluminium anodisé laqué blanc

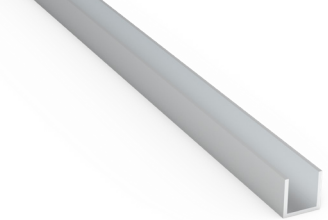
**Componentes**

Components | Composants

PERFILERÍA   PROFILES   PROFILS	Acabado	Cód.	المتر	📦
 <p>Conjunto Perfil <b>Funda FT XL + Star XL</b>. <b>Montaje entre paredes / falso techo.</b>                      Support FT XL + Star XL track set. Mounting between walls / false ceiling.                      Jeu rail de couverture FT XL + Star XL. Fixation entre les murs / faux-plafond.</p> <p><b>Fijación en bayoneta   Bayonet mounting   Montage à baïonnette</b></p> <p>160kg  61x57 mm</p>	<p><b>S</b></p> <p><b>BL</b></p> <p><b>WL</b></p>	<p>0 161 20<sup>2</sup> 0 161 30<sup>2</sup> 0 161 40<sup>2</sup> 0 161 60<sup>2</sup></p> <p>0 161 21<sup>2</sup> 0 161 31<sup>2</sup> 0 161 41<sup>2</sup> 0 161 61<sup>2</sup></p> <p>0 161 22<sup>2</sup> 0 161 32<sup>2</sup> 0 161 42<sup>2</sup> 0 161 62<sup>2</sup></p>	<p>2 m 3 m 4 m 6 m</p> <p>2 m 3 m 4 m 6 m</p> <p>2 m 3 m 4 m 6 m</p>	<p>1 perfil 1 profile 1 profil</p>
 <p>Perfil inferior con burlete para vidrio corredero de 8-10-12mm                      Bottom track with brush for sliding glass of 8-10-12mm                      Rail inférieur avec bourrelet pour verre coulissant de 8-10-12mm</p> <p> 20x15mm</p>	<p><b>S</b></p>	<p>00 41 22 00 41 32 00 41 62</p>	<p>2 m 3 m 6 m</p>	<p>1 perfil 1 profile 1 profil</p>
 <p>Perfil inferior para vidrio fijo de 8-10-12mm                      Bottom track for fixed glass of 8-10-12mm                      Rail inférieur pour verre fixe 8-10-12mm</p> <p> 17x12mm</p>	<p><b>S</b></p> <p><b>BL</b></p> <p><b>WL</b></p>	<p>00 87 24 00 87 34 00 87 64</p> <p>00 71 86 00 71 81 00 71 87</p> <p>00 71 96 00 71 91 00 71 97</p>	<p>2 m 3 m 6 m</p> <p>2 m 3 m 6 m</p> <p>2 m 3 m 6 m</p>	<p>1 perfil 1 profile 1 profil</p>
 <p>Perfil inferior para vidrio fijo de 8-10-12mm                      Bottom track for fixed glass of 8-10-12mm                      Rail inférieur pour verre fixe 8-10-12mm</p> <p> 20x20mm</p>	<p><b>S</b></p>	<p>00 87 15 00 87 30 00 87 60</p>	<p>1,5 m 3 m 6 m</p>	<p>2 perfiles 2 profiles 2 profils</p>
 <p>Perfil inferior entrada frontal para vidrio fijo de 8-10-12 mm                      Bottom track front entry for fixed glass of 8-10-12mm                      Rail inférieur entrée frontale pour verre fixe de 8-10-12mm</p> <p> 21x20mm</p>	<p><b>S</b></p> <p><b>BL</b></p> <p><b>WL</b></p>	<p>0 110 22<sup>2</sup> 0 110 32<sup>2</sup> 0 110 62<sup>2</sup></p> <p>0 110 25<sup>2</sup> 0 110 35<sup>2</sup> 0 110 55<sup>2</sup></p> <p>0 110 24<sup>2</sup> 0 110 34<sup>2</sup> 0 110 64<sup>2</sup></p>	<p>2 m 3 m 6 m</p> <p>2 m 3 m 6 m</p> <p>2 m 3 m 6 m</p>	<p>1 perfil 1 profile 1 profil</p>

<sup>1</sup> Se sirve con tornillería | <sup>1</sup>Served with screws | <sup>1</sup>Servi avec vis. **2 m** - 6 tornillos | screw | vis **3 m** - 8 tornillos | screw | vis **4 m** - 11 tornillos | screw | vis **6 m** - 16 tornillos | screw | vis

<sup>2</sup> El perfil incluye junta + juegos de tapas laterales | <sup>2</sup>This profile includes PVC joints + set of end caps | <sup>2</sup>Le profil inclue jointes plastiques + capuchons finals

**S** Aluminio anodizado plata mate  
Satin anodized aluminium  
Aluminium anodisé argent







**BL** Aluminio lacado negro  
Black lacquered aluminium  
Aluminium anodisé laqué noir

**WL** Aluminio lacado blanco  
White lacquered aluminium  
Aluminium anodisé laqué blanc



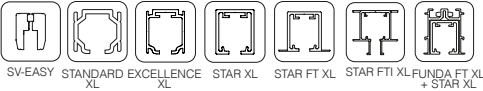

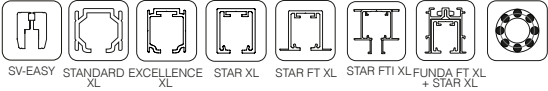

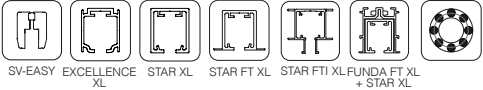
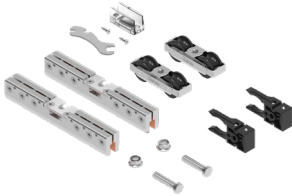
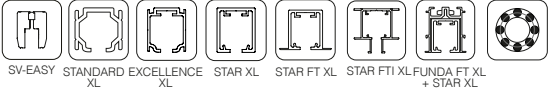

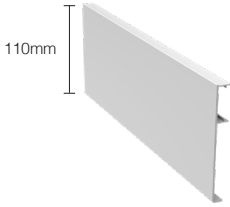

Componentes

Components | Composants

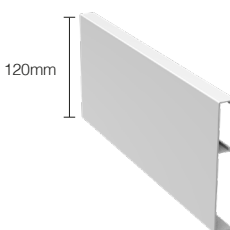
JUEGOS   SETS   JEUX	Acabado	Cód.		
 <p>Juego de accesorios <b>SV-A110 EASY</b>. x2 Freno retenedor SV-A110 EASY Fitting set. x2 Retaining brake Garniture SV-A110 EASY. x2 Frein de retenue</p>  <p>SV-EASY STANDARD XL EXCELLENCE XL STAR XL STAR FT XL STAR FTI XL FUNDA FT XL + STAR XL</p> <p><b>110kg</b></p>		0 110 00		1 juego 1 set 1 jeu
 <p>Juego de accesorios <b>SV-P140 EASY</b>. x2 Freno retenedor SV-P140 EASY Fitting set. x2 Retaining brake Garniture SV-P140 EASY. x2 Frein de retenue</p>  <p>SV-EASY STANDARD XL EXCELLENCE XL STAR XL STAR FT XL STAR FTI XL FUNDA FT XL + STAR XL</p> <p><b>140kg</b></p>		0 140 02		1 juego 1 set 1 jeu
 <p>Juego de accesorios <b>SV-P140 EASY</b>. x1 SofTop doble SV-P140 EASY Fitting set. x1 Double SofTop Garniture SV-P140 EASY. x1 Double SofTop</p>  <p>SV-EASY EXCELLENCE XL STAR XL STAR FT XL STAR FTI XL FUNDA FT XL + STAR XL</p> <p><b>140kg</b></p>		0 140 03		1 juego 1 set 1 jeu
 <p>Juego de accesorios <b>SV-A160 EASY</b>. x2 Freno retenedor SV-A160 EASY Fitting set. x2 Retaining stopper Garniture SV-A160 EASY. x2 Frein de retenue</p>  <p>SV-EASY STANDARD XL EXCELLENCE XL STAR XL STAR FT XL STAR FTI XL FUNDA FT XL + STAR XL</p> <p><b>160kg</b></p>		0 160 01		1 juego 1 set 1 jeu

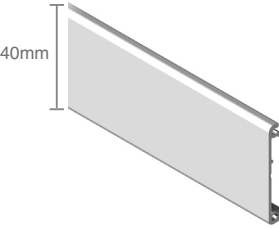
**Componentes**

Components | Composants







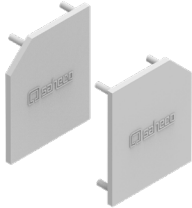

ACCESORIOS   ACCESSORIES   ACCESSOIRES		Acabado	Cód.	مقياس	📦
 <p>110mm</p>	<p>Tapeta para perfil <b>Standard XL</b>                      Pelmet cover for Standard XL track                      Cache pour rail Standard XL</p>  <p>STANDARD XL</p>	<p><b>S</b></p> <p><b>BL</b></p> <p><b>WL</b></p>	0 104 20 0 104 30 0 104 50	2 m 3 m 5 m	2 perfiles 2 profils 2 profils
			0 104 29 0 104 39 0 104 59	2 m 3 m 5 m	
			0 104 21 0 104 31 0 104 51	2 m 3 m 5 m	
 <p>120mm</p>	<p>Tapeta para perfil <b>Excellence XL</b>                      Pelmet cover for Excellence XL track                      Cache pour rail Excellence XL</p>  <p>EXCELLENCE XL</p>	<p><b>S</b></p> <p><b>BL</b></p> <p><b>WL</b></p>	0 104 25 0 104 35 0 104 45 0 104 65	2 m 3 m 4 m 6 m	2 perfiles 2 profils 2 profils
			0 104 27 0 104 37 0 104 47 0 104 67	2 m 3 m 4 m 6 m	
			0 104 26 0 104 36 0 104 46 0 104 66	2 m 3 m 4 m 6 m	
 <p>40mm</p>	<p>Tapeta para pinza <b>EASY XL</b>                      EASY XL clamp pelmet cover                      Cache-pince EASY XL</p>	<p><b>S</b></p> <p><b>BL</b></p> <p><b>WL</b></p>	00 64 29 00 64 39	2 m 3 m	2 perfiles 2 profils 2 profils
			00 67 24 00 67 34	2 m 3 m	
			00 67 21 00 67 31	2 m 3 m	
	<p>Juego de tapas laterales pinza <b>EASY</b>                      EASY Clamp lateral caps                      Jeu capuchons latéraux EASY</p>	<p><b>S</b></p> <p><b>BL</b></p> <p><b>WL</b></p>	00 80 77 00 80 78 00 80 75	8 mm 10 mm 12 mm	1 juego 1 set 1 jeu
			00 80 96 00 80 97 00 80 69	8 mm 10 mm 12 mm	
			00 80 93 00 80 94 00 80 68	8 mm 10 mm 12 mm	
	<p>Tapa lateral <b>Standard XL</b>                      Standard XL lateral cap                      Capuchon latéral Standard XL</p>  <p>STANDARD XL</p>	<p><b>SP</b></p>	0 125 57	25 piezas 25 pièces 25 pièces	
			<p>Juego de tapas laterales <b>Star XL</b>. Montaje a techo/pared                      Star XL lateral cap set. Ceiling/wall mounting                      Jeu de capuchons latéral Star XL. Fixation à plafond/mur</p>  <p>STAR XL</p>	<p><b>SP</b></p> <p><b>BP</b></p> <p><b>WP</b></p>	0 160 10 0 160 11 0 160 12

<b>WL</b> Aluminio lacado blanco White lacquered aluminium Aluminium anodisé laqué blanc	<b>SP</b> Plástico plata Silver plastic Plastique argent	<b>S</b> Aluminio anodizado plata mate Satin anodized aluminium Aluminium anodisé argent	<b>BL</b> Aluminio lacado negro Black lacquered aluminium Aluminium anodisé laqué noir
		<b>BP</b> Plástico negro Black plastic Plastique noir	<b>WP</b> Plástico blanco White plastic Plastique blanc



Componentes

Components | Composants

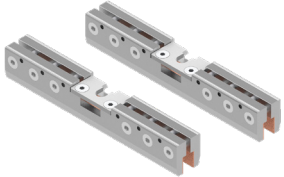
ACCESORIOS   ACCESSORIES   ACCESSOIRES		Acabado	Cód.	📏	📦
 <p>Juego de tapas laterales <b>Separador XL + Excellence XL / Star XL</b>. Montaje a pared. Separator XL + Excellence XL / Star XL lateral cap set. Wall mounting. Jeu de capuchons latéraux Séparateur XL + Excellence XL / Star XL. Fixation à mur.</p> <div style="display: flex; justify-content: space-around;"> <div style="text-align: center;"> <p>EXCELLENCE XL + SEPARADOR XL</p>  <p>49x60 mm</p> </div> <div style="text-align: center;"> <p>STAR XL + SEPARADOR XL</p>  <p>49x60 mm</p> </div> </div>	<div style="display: flex; flex-direction: column; gap: 10px;"> <div style="border: 1px solid black; background-color: #ccc; padding: 2px; width: 20px; text-align: center;">SP</div> <div style="border: 1px solid black; background-color: #333; color: white; padding: 2px; width: 20px; text-align: center;">BP</div> <div style="border: 1px solid black; background-color: #fff; padding: 2px; width: 20px; text-align: center;">WP</div> </div>	<p>0 160 13</p> <p>0 160 14</p> <p>0 160 15</p>			<p>1 juego 1 set 1 jeu</p>
 <p>Roldana <b>SV-A110</b> con tornillo SV-A110 Roller with screw Galet SV-A110 avec vis</p>		0 101 61			<p>25 piezas 25 pieces 25 pièces</p>
 <p>Roldana <b>SV-P140</b> con tornillo SV-P140 Roller with screw Galet SV-P140 avec vis</p> 		0 140 52			<p>25 piezas 25 pieces 25 pièces</p>
 <p>Roldana <b>SV-A160</b> con tornillo SV-A160 Roller with screw Galet SV-A160 avec vis</p> 		0 125 61			<p>25 piezas 25 pieces 25 pièces</p>
 <p>Juego pinza <b>SV-EASY XL</b> SV-EASY XL clamp set Jeu pince SV-EASY XL</p> <div style="border: 1px solid black; border-radius: 10px; padding: 2px; display: inline-block;">160kg</div>		0 160 59			<p>1 juego 1 set 1 jeu</p>



**SP** Plástico plata  
Silver plastic  
Plastique argent

**BP** Plástico negro  
Black plastic  
Plastique noir

**WP** Plástico blanco  
White plastic  
Plastique blanc

**Componentes**

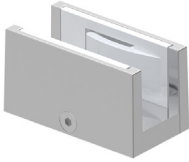
Components | Composants



ACCESORIOS   ACCESSORIES   ACCESSOIRES		Acabado	Cód.	📦
	<p>Guiador inferior plástico para vidrio de 8-12mm                      Plastic bottom guide for glass of 8-12mm                      Guide inférieur plastique pour verre de 8-12mm</p>	TP	00 40 57	25 piezas 25 pieces 25 pièces
	<p>Guiador inferior para vidrio de 8-14 mm                      Bottom guide for glass of 8-14mm                      Guide inférieur pour verre de 8-14mm</p>	<p>S</p> <p>BL</p> <p>WL</p>	<p>0 155 73</p> <p>00 71 80</p> <p>00 71 90</p>	1 pieza 1 piece 1 pièce
	<p>Freno retenedor doble <b>SV-A110 / A160</b>                      SV-A110/A160 Double retaining stopper                      Frein de retenue double SV-A110/A160</p>		0 101 52	10 piezas 10 pieces 10 pièces
	<p>Freno retenedor <b>SV-P140</b>                      SV-P140 Retaining stopper                      Frein de retenue SV-P140</p>		0 101 59	10 piezas 10 pieces 10 pièces

<b>TP</b>	Plástico transparente Transparent plastic Plastique transparent	<b>S</b>	Aluminio anodizado plata mate Satin anodized aluminium Aluminium anodisé argent
<b>BL</b>	Aluminio lacado negro Black lacquered aluminium Aluminium anodisé laqué noir	<b>WL</b>	Aluminio lacado blanco White lacquered aluminium Aluminium anodisé laqué blanc

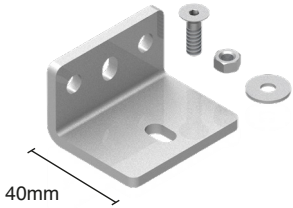
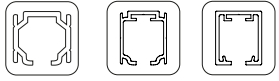
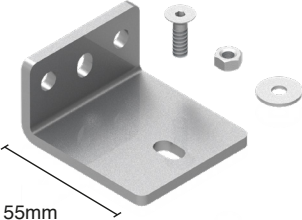

**Componentes**

Components | Composants

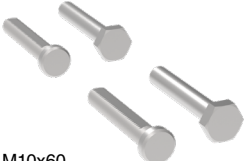
ACCESORIOS   ACCESSORIES   ACCESSOIRES	Acabado	Cód.	باركود	
 <p>40mm</p> <p>Soporte pared escuadra con regulación Adjustable wall fixing bracket Support équerre pour fixation à mur réglable</p>  <p>STANDARD XL EXCELLENCE XL STAR XL</p>		00 60 81 <sup>1</sup>		25 piezas 25 pieces 25 pièces
 <p>55mm</p> <p>Soporte pared escuadra con regulación Adjustable wall fixing bracket Support équerre pour fixation à mur réglable</p>  <p>STANDARD XL EXCELLENCE XL STAR XL</p>		00 60 82 <sup>1</sup>		25 piezas 25 pieces 25 pièces
 <p>M10x60</p> <p>Tornillería para perfil FTI. 1 puerta de madera y/o de cristal Screws for FTI track. 1 wooden and/or glass door Vis pour profil FTI. 1 porte bois et/ou verre</p>		0 140 70		1 juego 1 set 1 jeux

<sup>1</sup>Para las instalaciones que incorporen soporte pared aplicar uno por cada taladro | For sets that incorporate a wall support apply one for each drill hole | Pour les installations intégrant un support mural appliquer un support pour chaque trou percé. **2m** - 6 soportes | supports | supports **3m** - 8 soportes | supports | supports **4m** - 11 soportes | supports | supports **6m** - 16 soportes | supports | supports



# Essential Glass

SV-A300 | SV-LA300

# ESSENTIAL GLASS

BIBLIOTECA  
DE DESCARGAS



DOWNLOADS LIBRARY |  
BIBLIOTHÈQUE  
TÉLÉCHARGEMENTS

— ES

**SV-A300 / SV-LA300 SON SOLUCIONES DE PUERTAS CORREDERAS SUSPENDIDAS DE ALTA CALIDAD.** Ideal para divisiones y puertas de uso doméstico o comercial de gran formato.

**1.** Soportan un máximo de 300kg por hoja respectivamente. **2.** Roldanas con rodamiento a bolas. **3.** posibilidad de tapetas embellecedoras cubrepinzas. **4.** No se requiere mecanización del vidrio.

— EN

**SV-A300 / SV-LA300 SOLUTIONS FOR HIGH QUALITY SUSPENDED SLIDING DOORS.** Ideal for large-sized dividers and doors for home or commercial use.

**1.** They support a maximum of 300kg per panel respectively. **2.** Rollers with bearings, **3.** possibility of trim covers for the clamps. **4.** No machining of the glass is required.

— FR

**SV-A300 / SV-LA300 SONT DES SOLUTIONS DE PORTES COULISSANTES SUSPENDUES DE GRANDE QUALITÉ.** Idéales pour les divisions et portes grand format à usage résidentiel ou commercial.

**1.** Supportent un maximum de 300kg par battant respectivement. **2.** Montures avec roulements à billes. **3.** possibilité de caches enjoliveurs couvre-pinzas. **4.** N'exige pas l'usinage du verre.





### Características técnicas

Technical characteristics | Caractéristiques techniques

### Perfilería Profiles | Profils



54x53 mm



20x20 mm



12x17 mm



20x15 mm

### Especificaciones Specifications | Spécification



10-12 mm



RODAMIENTO A BOLAS  
BALL BEARING  
ROULEMENT À BILLES

### Peso Weight | Poids

300 kg

662 lb

### Producto certificado

Certificated product | Produit certifié



### Variantes de instalación

Installation possibilities | Variantes d'installation

**PARED**  
WALL  
MUR

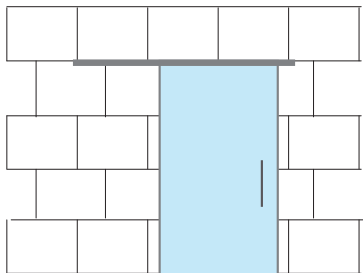

**PARED CON VIDRIO FJO**  
WALL WITH FIXED PANEL  
MUR AVEC VERRE FIXE

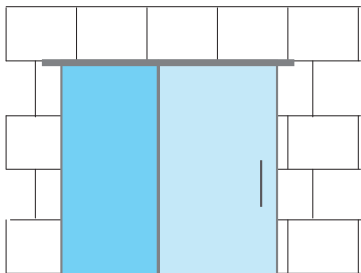

**TECHO**  
CEILING  
PLAFOND

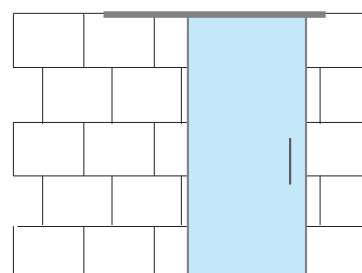

**TECHO CON VIDRIO FIJO**  
CEILING WITH FIXED PANEL  
PLAFOND AVEC VERRE FIXE

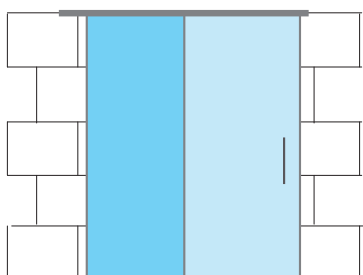

 **PUERTA CORREDERA** | SLIDING DOOR | PORTE COULISSANTE

 **VIDRIO FIJO** | FIXED GLASS | VERRE FIXE



**Sección tipo**

Cross-section | Section type (Cotas en mm | Dimensions in mm | Dimensions en mm)

**MONTAJE A TECHO | CEILING MOUNTING | FIXATION À PLAFOND**

Vidrio fijo | Fixed glass | Verre fixe

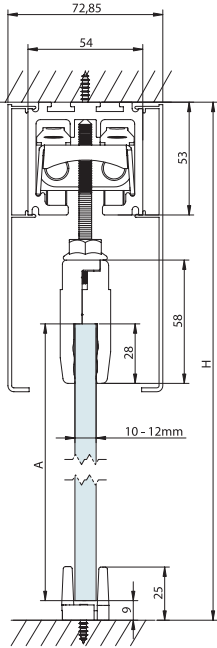

A= H-115

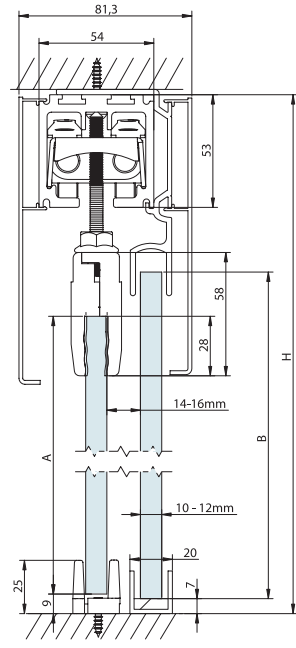

A= H-115

B= H-90

**MONTAJE A PARED | WALL MOUNTING | FIXATION À MUR**

Vidrio fijo | Fixed glass | Verre fixe

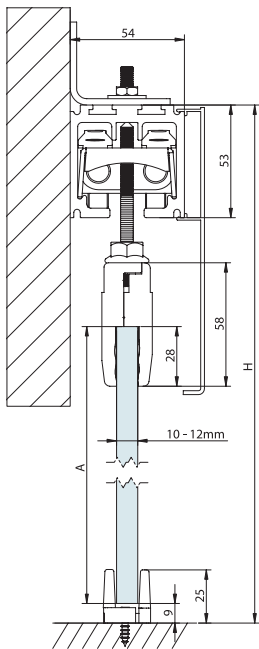

A= H-115

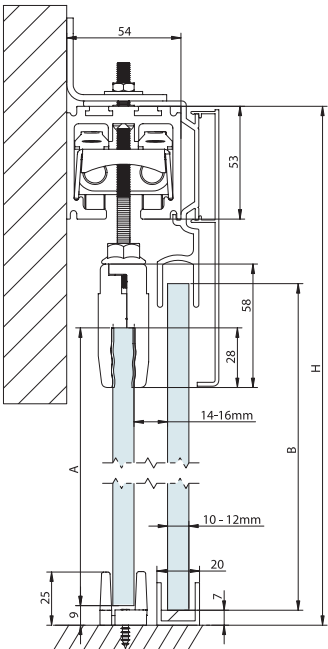

A= H-115

B= H-90



## Componentes

Components | Composants

PERFILERÍA   PROFILES   PROFILS		Acabado	Cód.		
	<p>Perfil superior Top track Rail supérieur</p>  <p>54x53mm</p>		<p>0 256 15 0 256 22 0 256 30 0 256 37 0 256 45 0 256 60</p>	<p>1,5 m 2,25 m 3 m 3,75 m 4,5 m 6 m</p>	<p>1 perfil 1 profile 1 profil</p>
	<p>Perfil para vidrio fijo <b>SV-A300</b> SV-A300 Fixed glass track Rail pour verre fixe SV-A300</p>		<p>0 203 20 0 203 30 0 203 50</p>	<p>2 m 3 m 5 m</p>	<p>2 perfiles 2 profiles 2 profils</p>
	<p>Soporte para vidrio fijo <b>SV-A300</b> SV-A300 Fixed glass fixing bracket Support pour verre fixe SV-A300</p>		<p>0 203 01</p>	<p>0,10 m</p>	<p>1 pieza 1 piece 1 pièce</p>
	<p>Perfil inferior para vidrio fijo de 8-10-12mm Bottom track for fixed glass of 8-10-12mm Rail inférieur pour verre fixe de 8-10-12mm</p>  <p>20x20mm</p>		<p>00 87 15 00 87 30 00 87 60</p>	<p>1,5 m 3 m 6 m</p>	<p>2 perfiles 2 profiles 2 profils</p>
	<p>Perfil inferior para vidrio fijo de 8-10-12mm Bottom track for fixed glass of 8-10-12mm Rail inférieur pour verre fixe de 8-10-12mm</p>  <p>17x12mm</p>		<p>00 87 24 00 87 34 00 87 64</p>	<p>2 m 3 m 6 m</p>	<p>1 perfil 1 profile 1 profil</p>
	<p>Perfil inferior con burlete de 8-10-12mm Bottom track with brush of 8-10-12mm Rail inférieur avec bourrelet de 8-10-12mm</p>  <p>20x15mm</p>		<p>00 41 22 00 41 32 00 41 62</p>	<p>2 m 3 m 6 m</p>	<p>1 perfil 1 profile 1 profil</p>
	<p>Perfil inferior entrada frontal para vidrio fijo de 8-10-12 mm Bottom track front entry for fixed glass of 8-10-12mm Rail inférieur entrée frontale pour verre fixe de 8-10-12mm</p>  <p>21x20mm</p>	<p></p> <p></p>	<p>0 110 22<sup>1</sup> 0 110 32<sup>1</sup> 0 110 62<sup>1</sup></p> <p>0 110 24<sup>1</sup> 0 110 34<sup>1</sup> 0 110 64<sup>1</sup></p>	<p>2 m 3 m 6 m</p> <p>2 m 3 m 6 m</p>	<p>1 perfil 1 profile 1 profil</p>

'El perfil incluye junta + juegos de tapas laterales | 'This profile includes PVC joints + set of end caps | 'Le profil inclue jointes plastiques + capuchons finals

**2 m** ..... 2 juegos de tapas | 2 set of caps | 2 set de caupuchons finals **3 m** ..... 4 juegos de tapas | 4 set of caps | 4 set de caupuchons finals

**6 m** ..... 6 juegos de tapas | 6 set of caps | 6 set de caupuchons finals



Aluminio anodizado plata mate  
Satin anodized aluminium  
Aluminium anodisé argent



Componentes

Components | Composants







JUEGOS   SETS   JEUX		Acabado	Cód.		
 <p>Juego de accesorios <b>SV-A300</b> para vidrio de 10-12 mm SV-A300 Fitting set for glass of 10-12 mm Garniture SV-A300 pour verre de 10-12 mm</p> <p><b>300kg</b></p>		0 206 00			1 juego 1 set 1 jeu
ACCESORIOS   ACCESSORIES   ACCESSOIRES		Acabado	Cód.		
 <p>Pinza Reg. <b>SV-LA300</b> Superior SV-LA300. Top adjustable clamp Pince Réglable SV-LA300 Supérieure</p> <p>Componentes <b>SV-LA300</b> Pinza Sup. 60-80 cm SV-LA300 components. Top clamp. 60-80 cm Composants SV-LA300 Pince Sup. 60-80 cm</p> <p>Componentes <b>SV-LA300</b> Pinza Sup. 90-120 cm SV-LA300 components. Top clamp. 90-120 cm Composants SV-LA300 Pince Sup. 90-120 cm</p>		0 290 60 0 290 70 0 290 80 0 290 90 290 100 290 110 290 120	0,60 m 0,70 m 0,80 m 0,90 m 1,00 m 1,10 m 1,20 m		1 pieza 1 piece 1 pièce
		0 267 61	0,90 m		1 pieza 1 piece 1 pièce
		0 267 62	1,20 m		1 pieza 1 piece 1 pièce
 <p>Pinza Reg. <b>SV-LA300</b> Inferior SV-LA300. Bottom adjustable clamp Pince Réglable SV-LA300 Inférieure</p> <p>Componentes <b>SV-LA300</b> Pinza Inf. 60-80 cm SV-LA300 components. Bottom clamp. 60-80 cm Composants SV-LA300 Pince Inf. 60-80 cm</p> <p>Componentes <b>SV-LA300</b> Pinza Inf. 90-120 cm SV-LA300 components. Bottom clamp. 90-120 cm Composants SV-LA300 Pince Inf. 90-120 cm</p>		0 267 60 0 267 70 0 267 80 0 267 90 267 100 267 110 267 120	0,60 m 0,70 m 0,80 m 0,90 m 1,00 m 1,10 m 1,20 m		1 pieza 1 piece 1 pièce
		0 267 63	0,90 m		1 pieza 1 piece 1 pièce
		0 267 64	1,20 m		1 pieza 1 piece 1 pièce
 <p>Roldana <b>SV-A300</b> SV-A300 Roller Galet SV-A300</p>  <p>RODAMIENTO A BOLAS BALL BEARING ROULEMENT À BILLES</p>		0 300 62			2 piezas 2 pieces 2 pièces
 <p>Freno retenedor Retaining stopper Frein de retenue</p>		0 300 63			2 piezas 2 pieces 2 pièces

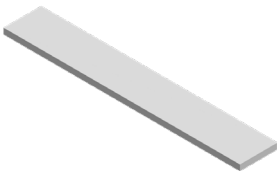

## Componentes

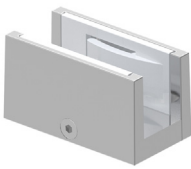
Components | Composants

### ACCESORIOS | ACCESSORIES | ACCESSOIRES

	<p>Conector <b>SV-A300</b>  SV-A300 connector  Connecteur SV-A300</p>		0 300 67		10 piezas 10 pieces 10 pièces
	<p>Guiador inferior plástico para vidrio de 8-12mm  Plastic bottom guide for glass of 8-12mm  Guide inférieur plastique pour verre de 8-12mm</p>		00 40 57		25 piezas 25 pieces 25 pièces
	<p>Guiador inferior para vidrio de 8-14 mm  Bottom guide for glass of 8-14mm  Guide inférieur pour verre 8-14mm</p>	<p><b>S</b></p> <p><b>WL</b></p> <p><b>BL</b></p>	0 155 73 00 71 90 00 71 80		1 pieza 1 piece 1 pièce
	<p>Soporte pared  Wall support  Support mur</p>		0 300 64 <sup>1</sup>		25 piezas 25 pieces 25 pièces
	<p>Embellecedor final perfil  Final trim track  Capuchon final rail</p>		0 300 57		25 piezas 25 pieces 25 pièces
	<p>Juego pinza <b>SV-A300</b> regulable <b>SV-4</b>  SV-A300 SV-4 Adjustable clamp set  Jeu de pinces SV-A300 réglables SV-4</p>		0 125 58		1 juego 1 set 1 jeu

<sup>1</sup>Para las familias que incorporen soporte pared con perfilera de 2 m, 3 m o 5 m, aplicar uno por cada taladro | <sup>1</sup>For sets that incorporate a wall support with 2m, 3m, 5m or 6m profiling, apply one for each drill hole | <sup>1</sup>Pour les familles intégrant un support mural avec huisserie de 2m, 3m, 5m ou 6m, appliquer un support pour chaque trou percé.

2 m - 10 soportes pared | supports wall | supports muraux 3 m - 15 soportes pared | supports wall | supports muraux 5 m - 25 soportes pared | supports wall | supports muraux



**Aluminio anodizado plata mate**  
Satin anodized aluminium  
Aluminium anodisé argent



**Aluminio lacado blanco**  
White lacquered aluminium  
Aluminium anodisé laqué blanc



**Aluminio lacado negro mate**  
Matt black lacquered aluminium  
Aluminium anodisé laqué noir mat



**Componentes**

Components | Composants

ACCESORIOS   ACCESSORIES   ACCESSOIRES		Acabado	Cód.			
<p>130mm</p>	<p>Tapeta Pelmet cover Cache</p>	<div style="background-color: black; color: white; padding: 2px; display: inline-block;">S</div>	0 204 20	2 m		
			0 204 30	3 m		
			0 204 50	5 m		
		<div style="border: 1px solid black; padding: 2px; display: inline-block;">WL</div>	0 204 21	2 m		2 u.
			0 204 31	3 m		2 u.
			0 204 51	5 m		2 u.
<div style="background-color: black; color: white; padding: 2px; display: inline-block;">SSS</div>	0 204 32	3 m				
	<p>Perfil plástico salvacantos Plastic edge trim track Rail plastique protège-coins</p>		00 86 30	3 m	2 piezas 2 pieces 2 pièces	
	<p>Cepillo para pinza <b>SV-LA300</b> SV-LA300 Brush for glass clamp Brosse pour pince SV-LA300</p>		0 266 29 (19mm)	3 m	1 pieza 1 piece 1 pièce	
0 266 30 (14mm)						
	<p>Cepillo Autoadhesivo Salvacantos Self-sticking edge trim brush Brosse auto-adhésive protège-coins</p>		0 266 31	3 m	1 pieza 1 piece 1 pièce	
	<p>Guiador inferior <b>SV-LA300</b> SV-LA300 Bottom guide Guide inférieur SV-LA300</p>		0 300 65		1 pieza 1 piece 1 pièce	
	<p>Guiador inferior Bottom guide Guide inférieur</p>		00 41 40		25 piezas 25 pieces 25 pièces	



# Bloq Glass

SV-Q60 | SV-Q110

# BLOQ

## g l a s s

**BLOQ** es una familia de sistemas para puertas correderas de vidrio que destaca por su calidad, diseño, tecnología de vanguardia, fácil instalación y un compromiso firme con la sostenibilidad.

Un producto con un diseño excepcional que se percibe en cada experiencia de uso y con un objetivo claro: reducir dimensiones e incrementar prestaciones.

### Características principales:

- Sistema para aplicaciones domésticas y comerciales, soportando un peso de hasta **60Kg** para su versión **SV-Q60** y **110Kg** para la **SV-Q110**.
  - **Perfilería compacta** que combina funcionalidad, estética y ahorro de espacio, ofreciendo una solución versátil y elegante para diferentes espacios y necesidades.
  - **3 únicos perfiles** ( con vidrio fijo incluido) para todas las variantes de instalación y pesos disponibles.
  - Perfilera en **distintos acabados** para una máxima adaptación arquitectónica.
  - Instalación a pared, pared-pared, techo, falso techo y falso techo a dintel con o sin vidrio fijo.
  - Pinza con **nueva tecnología anti-descarrilamiento** (mediante roldana con rodamiento a bolas) segura y con mayor capacidad de tracción.
  - **Rodamiento a bolas** para un deslizamiento suave y silencioso.
  - **600mm de mínimo de ancho de puerta** (SV-Q60) y **680mm** (SV-Q110) con freno amortiguador incorporado.
  - **Freno amortiguador SofTop** de doble acción (apertura y cierre) **y registrable:** posibilidad de añadirlo o suprimirlo una vez ya realizada la instalación.
  - **Todos los ajustes son frontales**, haciendo de la instalación un proceso increíblemente fácil.
- No se requiere mecanización del vidrio** en ninguna de las aplicaciones.
- Certificado Applus+** según la norma **EN 1527** para toda la familia. Grado de durabilidad de **200.000 ciclos** de ensayo y Grado de corrosión 4: 240h y **con SofTop** Grado de durabilidad 6:100.000 ciclos y Grado de corrosión 4: 240h en cámara de niebla salina.
- **Nuevo packaging:** más **sostenible** que nunca.

### BIBLIOTECA DE DESCARGAS



### VIDEO DE MONTAJE



es más...





...  
**calidad**  
**diseño**  
**tecnología**  
**fácil instalación**  
**sostenibilidad**

# Perfilería

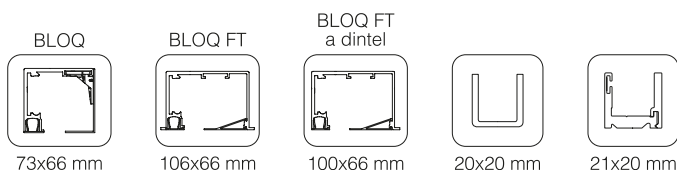

La perfilería de la familia **BLOQ GLASS** cuenta con un diseño sobresaliente, creado con el propósito firme de reducir dimensiones en todas sus facetas y elevar sus prestaciones al máximo exponente.

Elegancia, tecnología punta y facilidad de instalación se unen para convertir a la perfilería BLOQ en el *must* de los sistemas compactos.

## 4

### /Características

- Familia con **solo 3 guías**: perfil visto (pared y techo), perfil falso techo y perfil falso techo a dintel. Cada uno de ellos permite instalación con **corredera y corredera + vidrio fijo** y es apto para **60 kg y 110 kg**, lo que la hace perfecta para **optimizar el stock**.
- **Dimensiones reducidas**: 73x66mm (perfil visto).
- Compatible hasta **60Kg/hoja** para su juego de accesorios **SV-Q60** y **110Kg/hoja** para **SV-Q110**.
- Se sirve con **pre-mecanizado** avellanado a pared.
- Sin necesidad de registro gracias a sus **periféricos registrables**: retenedor, activadores, etc.
- **Acabados disponibles**: anodizado plata mate, lacado blanco mate y negro mate y, para la más completa personalización, se ofrece en acabado natural.

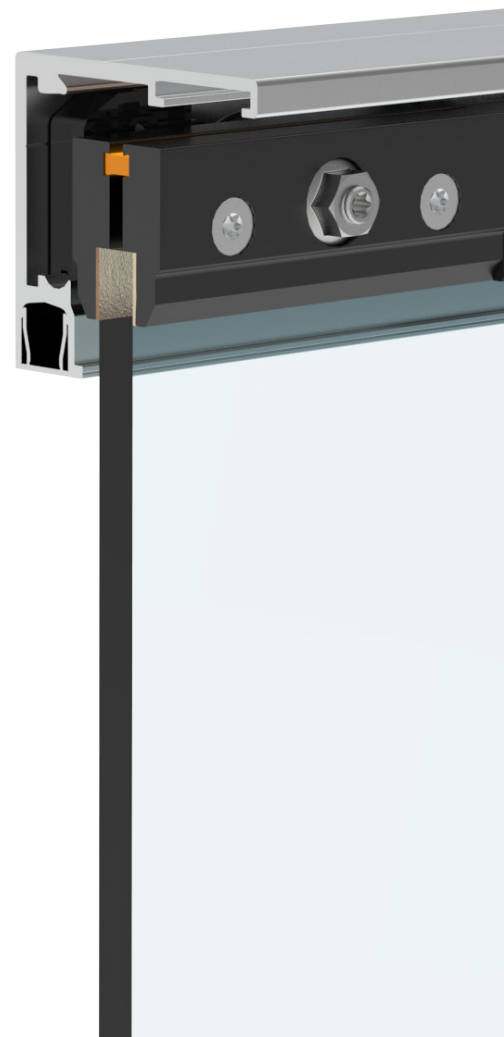

### /Clip para tapeta

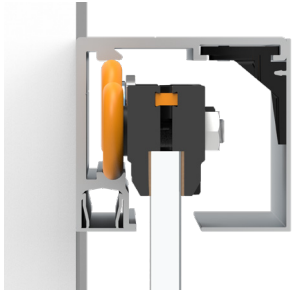

**Clip para tapeta** con geometría pensada para reforzar la rigidez de la tapeta.

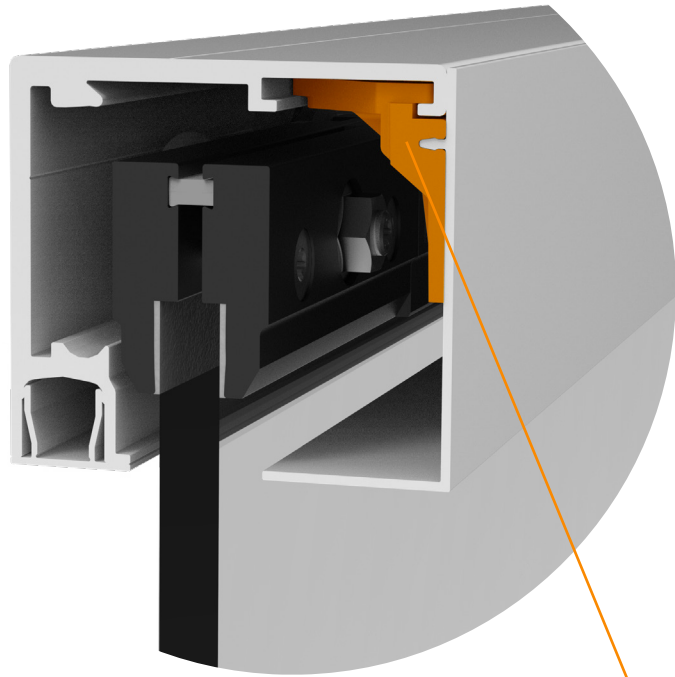

# Pequeñas dimensiones, grandes prestaciones

# Perfilería

## /Tapeta Cube

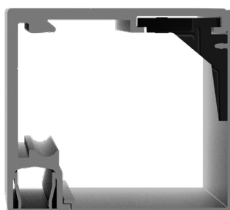

**Tapeta Cube:** concepto BLOQ (compacto) en su máxima expresión.



## Accesorios

### /Conector de guías

- El conector de guías **se sirve como accesorio** y es la elección perfecta para **ampliar la oferta de longitudes de guía y optimizar los costes de transporte**.
- **Las guías se unen y alinean** entre sí con el conector de guías en la transición entre dos módulos, **atornillando el conector directamente a las guías**. De este modo, se **minimiza cualquier interferencia en el paso de la roldana**, asegurando una transición suave y fluida.

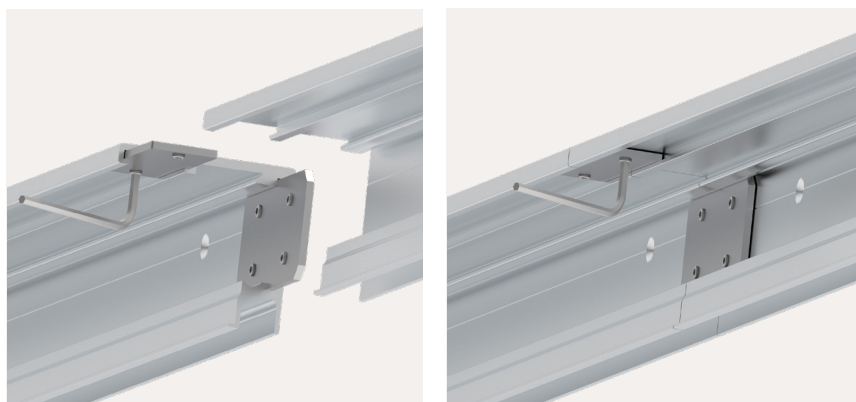

7

### /Soporte flotante

- **Soportes flotantes ocultos para instalación pared-pared** con capacidad de hasta 60 kg. incluidos en los juegos y kits de montaje SV-Q60.
- Fácil instalación gracias al diseño del perfil superior, el cual funciona mediante **clipaje frontal a los soportes de pared** que se fijan lateralmente, garantizando una instalación estable y segura.

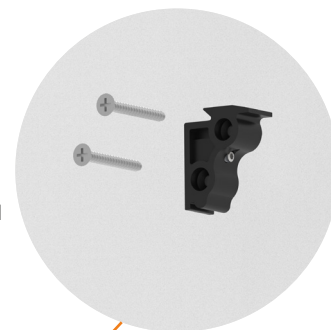

# Pinzas

La pinza de cualquier sistema de puertas correderas debe ser sinónimo de calidad, seguridad, facilidad de montaje y durabilidad; BLOQ cumple todos los requisitos y además, se viste de negro para la ocasión.

Te lo contamos.

**Rodamiento a bolas** para un deslizamiento, suave, silencioso y con mínimo esfuerzo.

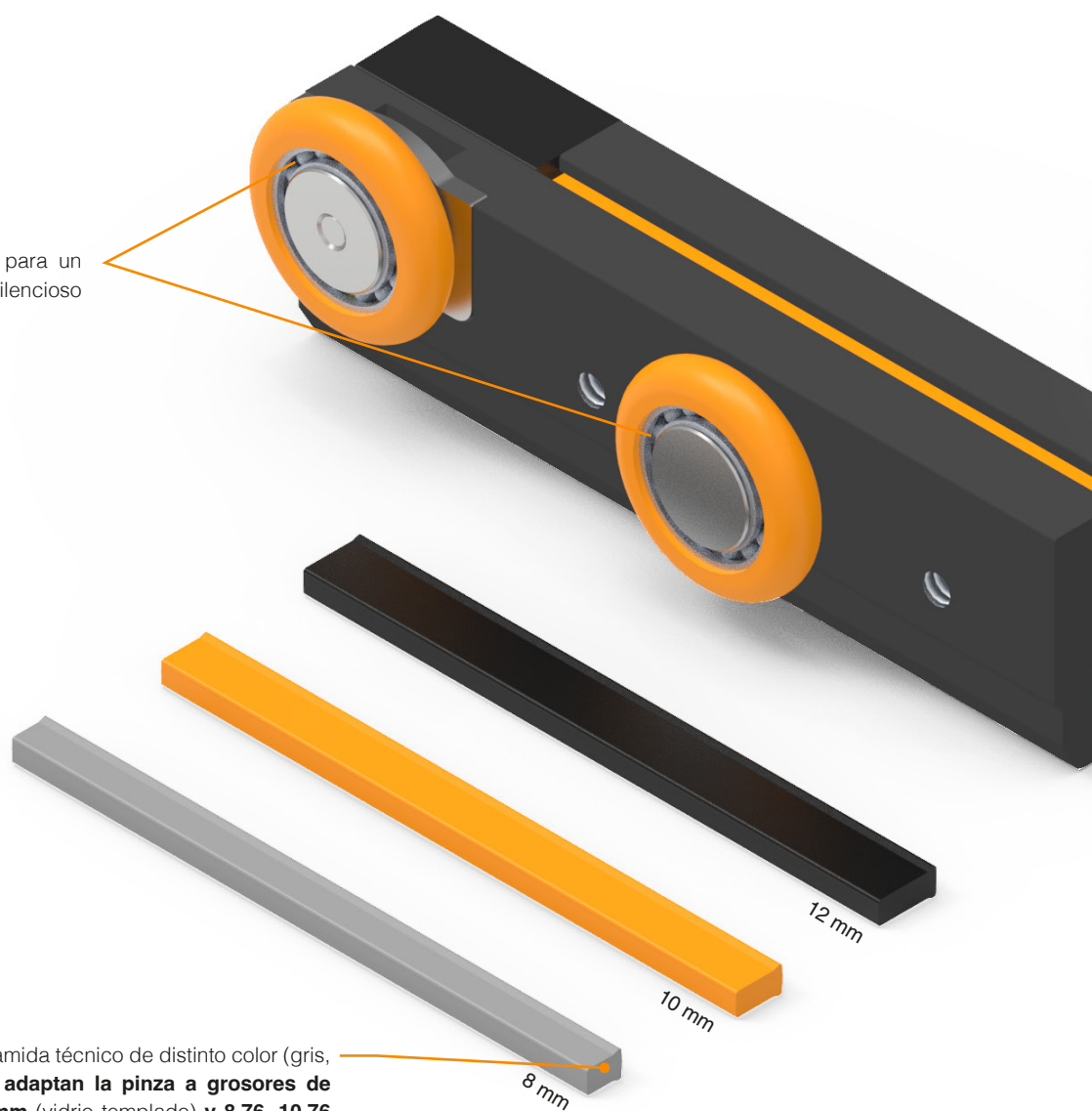

**Tres grosores** de poliamida técnico de distinto color (gris, naranja y negro) **que adaptan la pinza a grosores de vidrio de 8, 10 y 12 mm** (vidrio templado) **y 8.76, 10.76 y 12.76** (vidrio laminado). Decimos adiós a los tornillos de ajuste del grosor de cristal para dar la bienvenida a una solución rápida y eficaz.

**/Roldana anti-descarrilamiento:**

- **Tecnología de vanguardia:** protege a la puerta contra el descabalgamiento incluso cuando se somete a movimientos bruscos.
- **Fácil instalación:** la roldana anti-descarrilamiento se desbloquea, y posteriormente se bloquea con el perfil, con un sencillo giro de la llave TX30.
- **Nivel de seguridad superior:** gracias a la eliminación de holguras, el nuevo sistema garantiza una mayor seguridad y un deslizamiento más suave debido a la roldana con rodamiento a bolas.

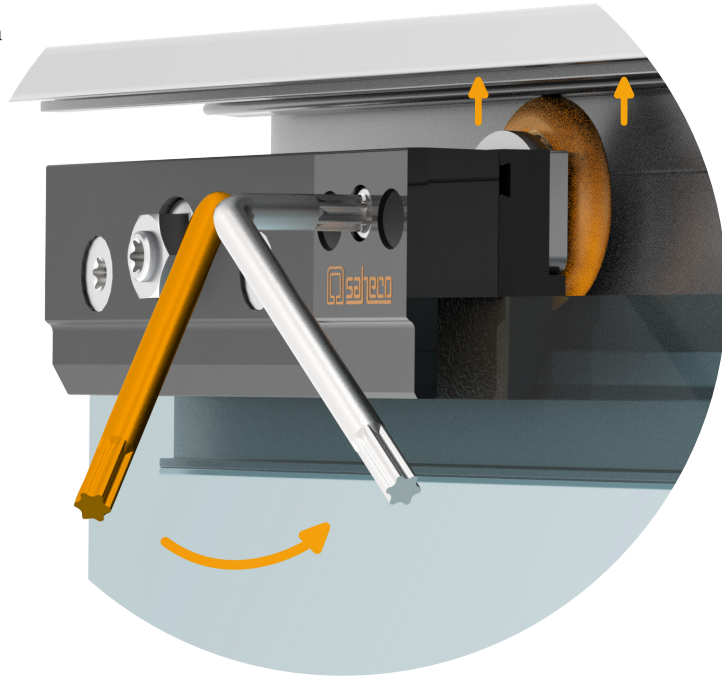

**Capacidad de tracción superior**  
en comparación a modelos  
anteriores de mordaza.

Todos los **ajustes son frontales** y **solo es necesaria una llave torx TORX® (TX 30)**: la mejor opción de atornillado gracias a su mejor transmisión del par de apriete y al reducido riesgo de dañar la muesca del tornillo.

# Bloq in black

# Sistema de amortiguación

Los sistemas de amortiguación permiten un cierre y apertura suaves y sin impactos, alargan la vida del producto y ofrecen seguridad en tu hogar u oficina. ¿Te imaginas, además, poder instalarlos en puertas extremadamente estrechas y con un mínimo esfuerzo de apertura?

**SofTop** lo hace posible.

## /SofTop SV-Q60 | SV-Q110

- Instalable con tan solo un mínimo de hoja de 600mm (SV-Q60) y 680mm (SV-Q110).
- **Amortiguación de doble acción** (apertura y cierre) en los últimos 10 cm de recorrido utilizando un único componente.
- **Reducción del esfuerzo de apertura en un 40%** (27N para SV-Q60 y 40N para SV-Q110), aportando así un extra de comodidad en cada movimiento.
- Disposición horizontal sobre la hoja corredera lo que asegura **mayor estabilidad**.
- Activadores que permiten la **regulación independiente de la hoja** en cualquier fase de la instalación.
- **Registrable**: posibilidad de añadirlo o suprimirlo una vez ya realizada la instalación.
- **Tres grosores** de poliamida técnico de distinto color (gris, naranja y negro) **que adaptan las pinzas del SofTop a grosores de vidrio de 8, 10 y 12 mm** (vidrio templado) **y 8.76, 10.76 y 12.76** (vidrio laminado)
- **Certificado Applus+** según la norma **EN 1527** para toda la familia. Grado de durabilidad de **200.000 ciclos** de ensayo y Grado de corrosión 4: 240h y **con SofTop** Grado de durabilidad 6: 100.000 ciclos y Grado de corrosión 4: 240h en cámara de niebla salina.

## /Retenedores (sin SofTop)

- **Registrables** y con **inserto metálico para mayor robustez**
- **Actúan directamente contra la rueda** aportando más retención.
- **Los retenedores se instalan frontalmente**, con la posibilidad de añadirlos o suprimirlos una vez ya realizada la instalación.

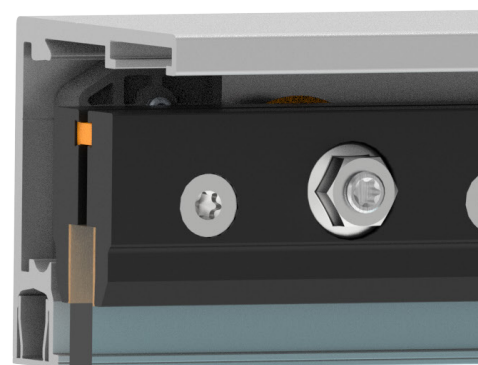

## /Activadores SofTop

- El funcionamiento del **SofTop opera independientemente a la regulación en altura** de la instalación, gracias a la nueva disposición de los activadores en relación con la del propio SofTop.
- Activadores de plástico técnico e **inserto metálico** para dar un punto **extra de rigidez a la fijación**.
- **Los activadores se instalan frontalmente**, con la posibilidad de añadirlos o suprimirlos una vez ya realizada la instalación.
- Para una fácil instalación de los activadores **el SofTop se provee de dos marcas que indican la posición donde deben colocarse**.

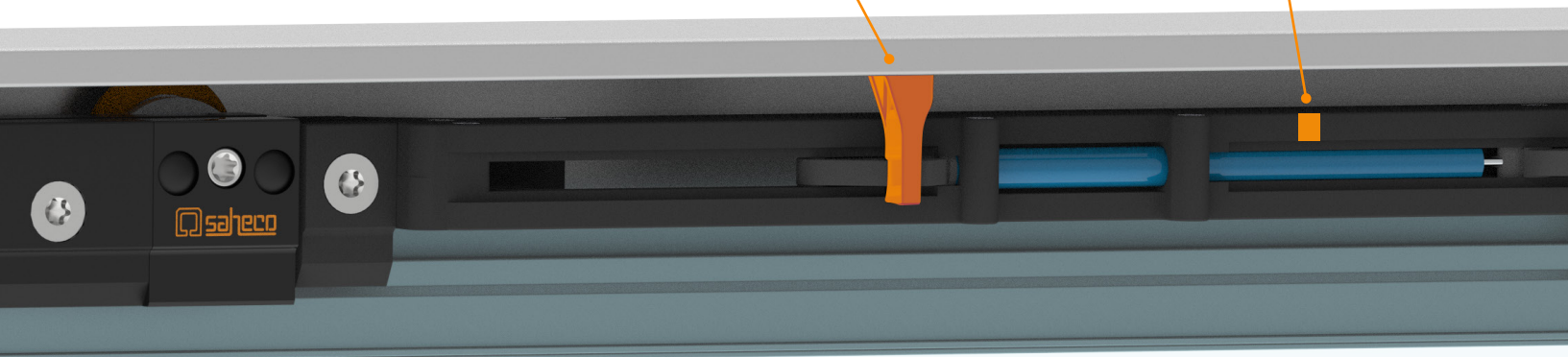
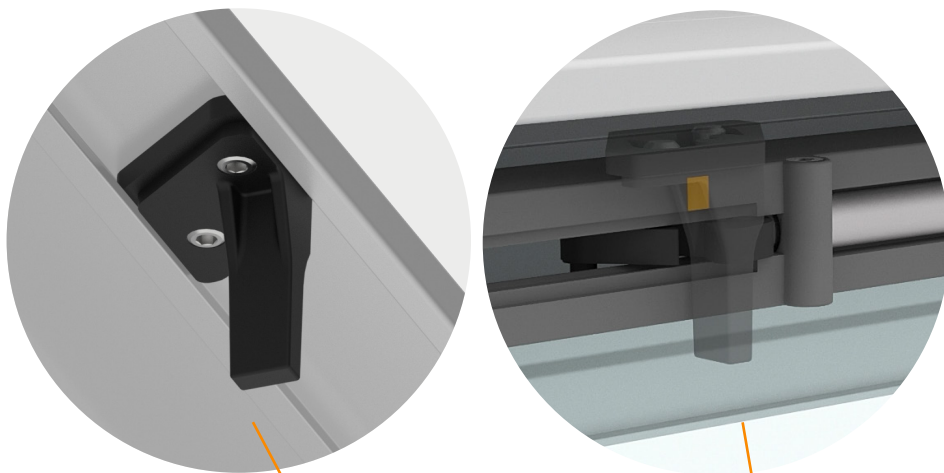

Instalación frontal, con la posibilidad de añadirlo o suprimirlo en cualquier momento.

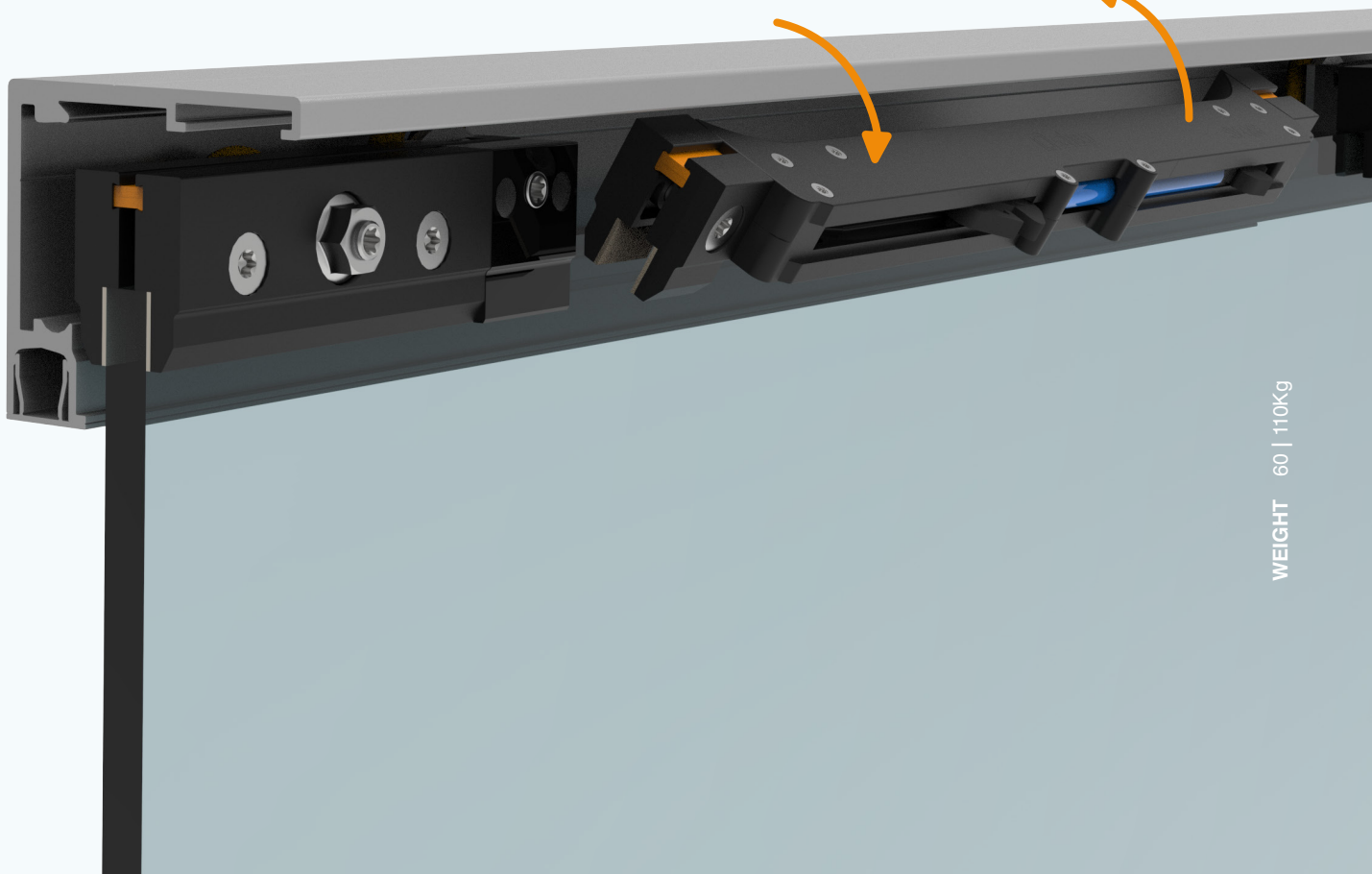

# Garantía y sostenibilidad

La **excelencia en calidad** es parte fundamental de nuestra cultura corporativa. Con BLOQ nos hemos propuesto ir más allá y proporcionar **un sistema con más valor añadido**:

- Ofrecemos Certificado Applus+ según normativa EN1527 de **200.000 ciclos de durabilidad** para sistemas con freno retenedor, duplicando, de este modo, los estándares fijados hasta el momento del producto Saheco.
- Creemos firmemente en lo que hacemos y por ello ampliamos la **garantía**, pasando de 5 a **10 años**.



# Altos estándares, mínimo impacto ambiental



Cuidar del medio ambiente es cuidar de nosotros mismos y de las generaciones venideras, BLOQ aplica las siguientes prácticas para ayudar en la **minimización del impacto ambiental:**

- **Fabricación 100% nacional** para minimizar la huella logística de los materiales.
- **Disponemos de planta de inyección de plástico propia y usamos plástico reciclado** en componentes de nuestros productos.
- **En todos nuestros embalajes** apostamos por cajas de cartón recicladas y reciclables.
- **Trabajamos en el reciclaje del aluminio**, comprometidos con la reducción de emisiones al prolongar el ciclo de vida de los materiales.



# Variantes de instalación

PARED

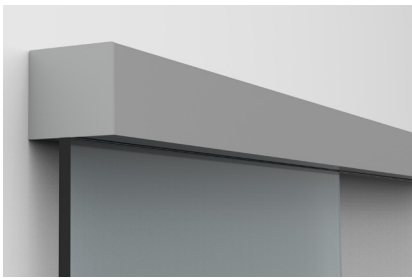
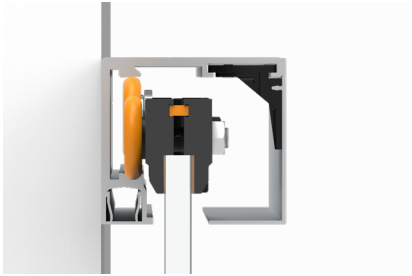

PARED CON VIDRIO FIJO

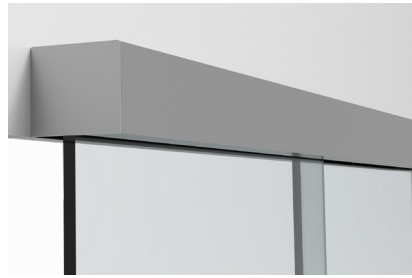
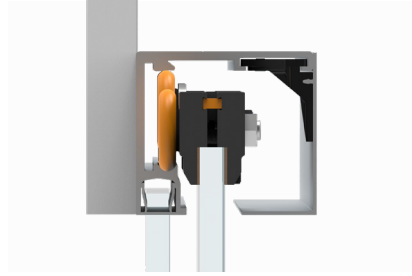

TECHO

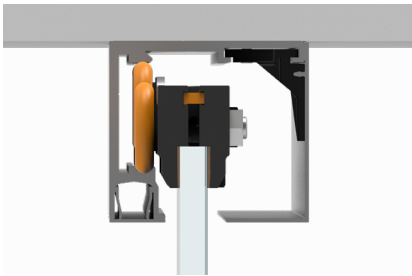

TECHO CON VIDRIO FIJO

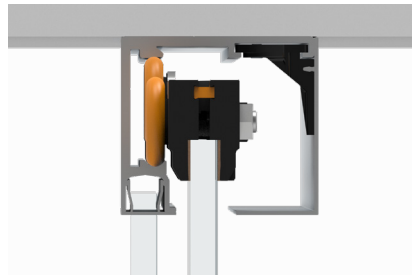

FALSO TECHO

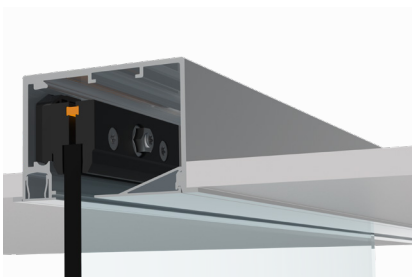

FALSO TECHO CON VIDRIO FIJO

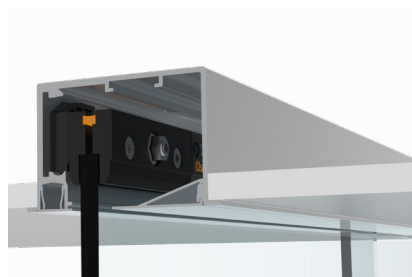
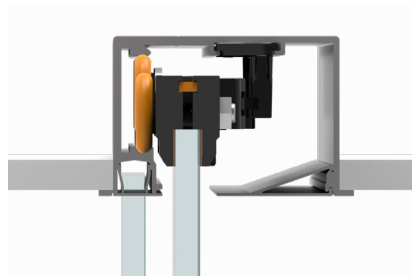

FALSO TECHO A DINTEL

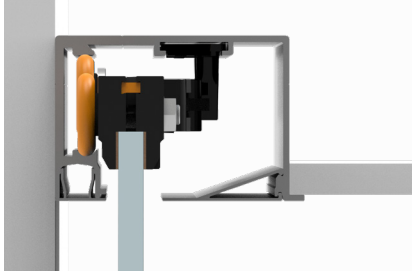

FALSO TECHO DINTEL  
CON VIDRIO FIJO

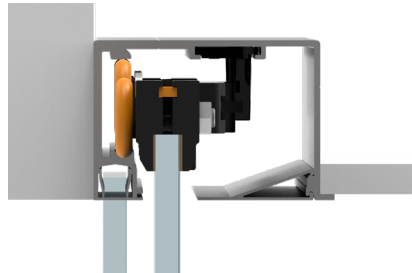

PARED DE VIDRIO

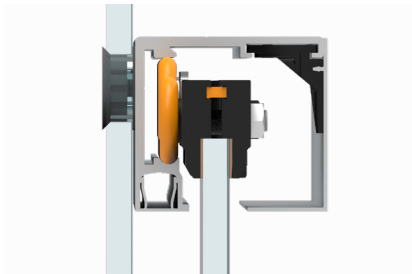

PARED-PARED

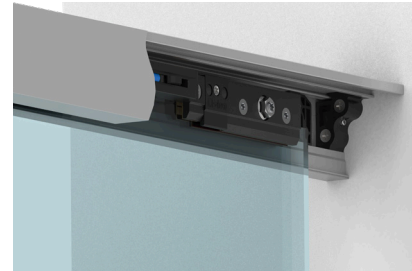
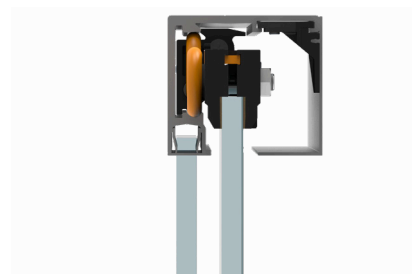

TAPETA CUBE

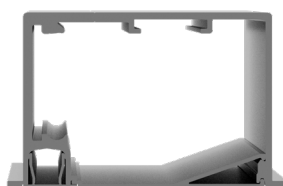
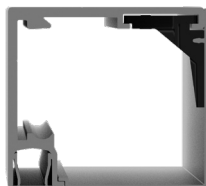

# Sección tipo

(Cotas en mm)

## /Montaje a pared

SV-Q60  
SV-Q110

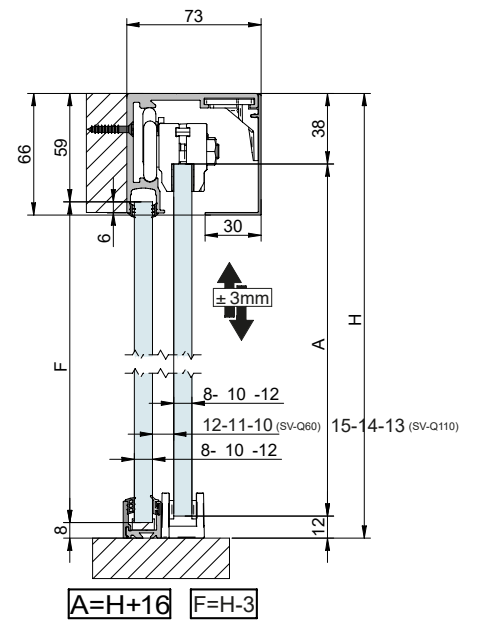
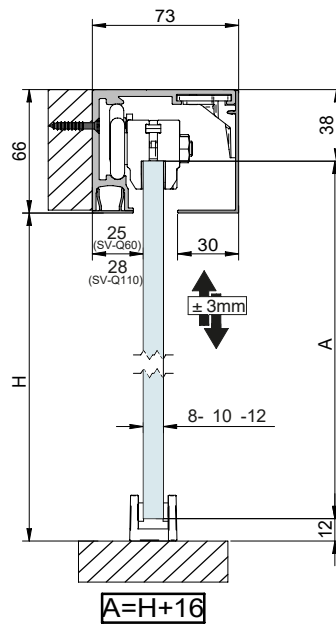

## /Montaje a techo

SV-Q60  
SV-Q110

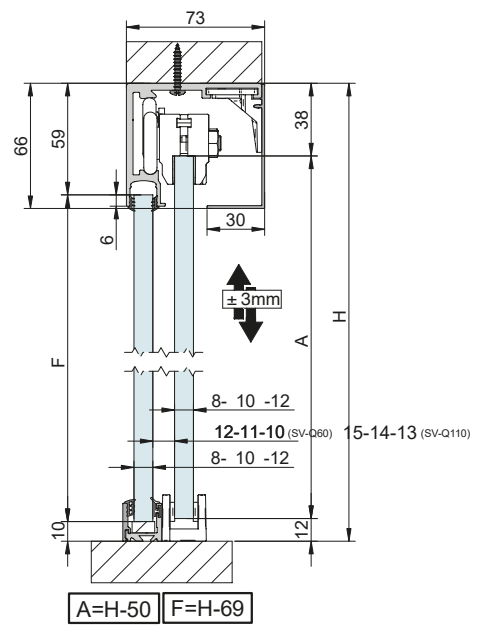
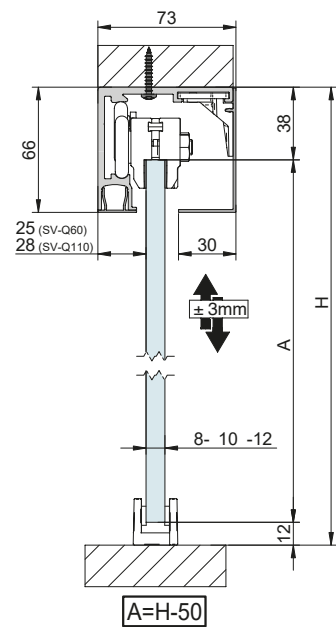

**/Montaje a falso techo**

SV-Q60  
SV-Q110

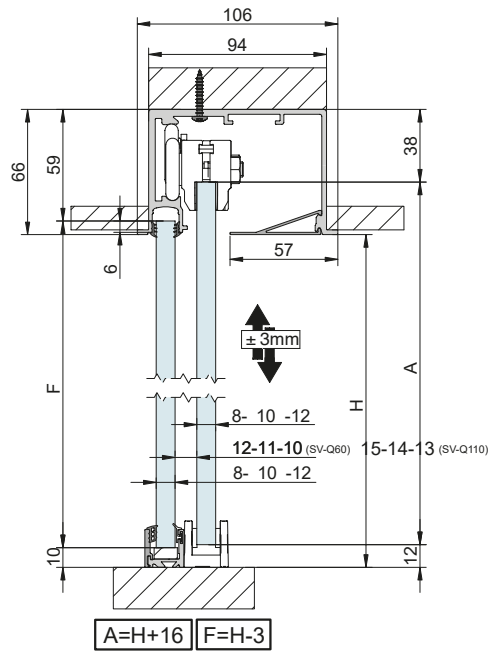
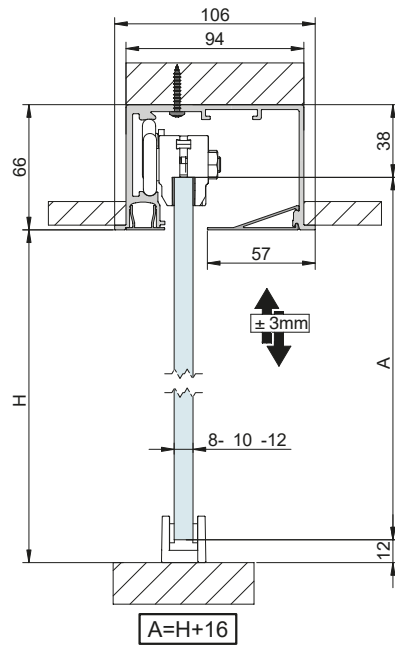

**/Montaje falso techo a dintel**

SV-Q60  
SV-Q110

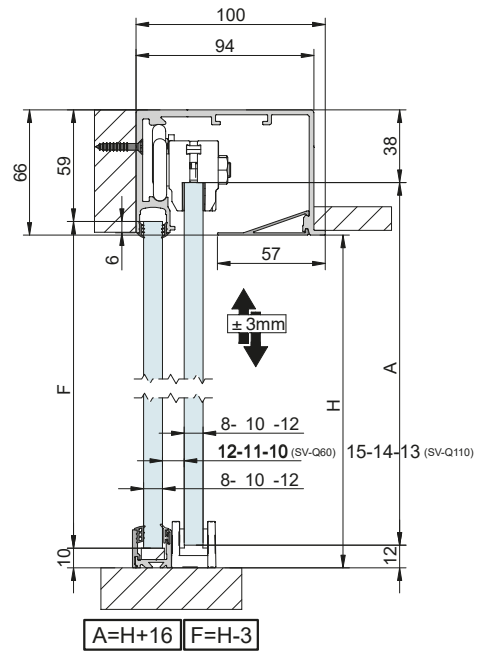
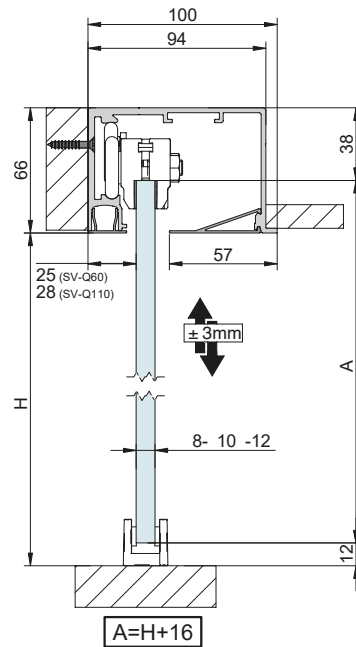

**/Montaje a pared de vidrio**

SV-Q60  
SV-Q110

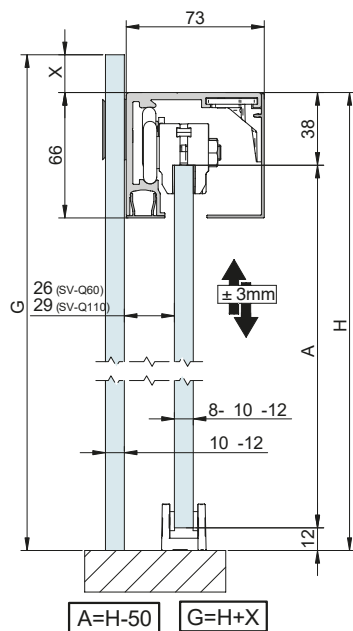

**/Tapeta Cube**

SV-Q60  
SV-Q110

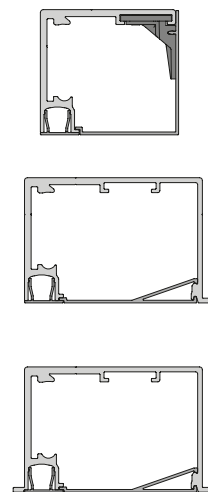

# Componentes

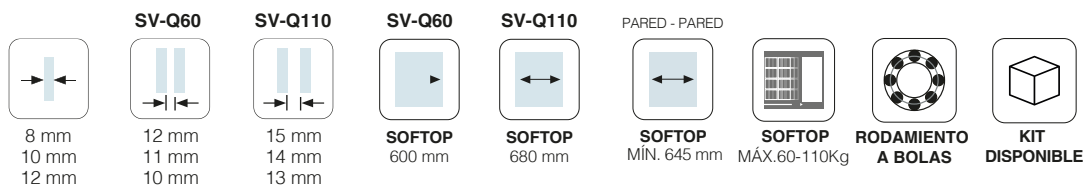

18

## /Perfilería

	Acabado	Cód.		
<p>Conjunto perfil superior corredero / corredero + vidrio fijo <b>BLOQ.</b></p> <p>73x66 mm</p>	MF	0 113 23	2 m	1 juego
		0 113 33	3 m	
		0 113 43	4 m	
		0 113 63	6 m	
	S	0 112 20	2 m	
		0 112 30	3 m	
		0 112 40	4 m	
		0 112 60	6 m	
	WL	0 112 22	2 m	
		0 112 32	3 m	
		0 112 42	4 m	
		0 112 62	6 m	
BL	0 112 23	2 m		
	0 112 33	3 m		
	0 112 43	4 m		
	0 112 63	6 m		
<p>Conjunto perfil superior corredero / corredero + vidrio fijo <b>BLOQ FT.</b> Montaje a falso techo.</p> <p>106x66 mm</p>	MF	0 113 24	2 m	1 juego
		0 113 34	3 m	
		0 113 44	4 m	
		0 113 64	6 m	
	S	0 112 24	2 m	
		0 112 34	3 m	
		0 112 44	4 m	
		0 112 64	6 m	
	WL	0 112 25	2 m	
		0 112 35	3 m	
		0 112 45	4 m	
		0 112 65	6 m	
BL	0 112 26	2 m		
	0 112 36	3 m		
	0 112 46	4 m		
	0 112 66	6 m		

\*El número de clips varía según el largo del perfil: 2m = 4 clips | 3m = 6 clips | 4m = 8 clips | 6m = 10m

/Perfilería

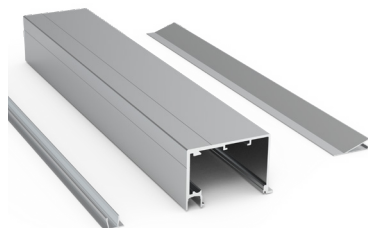

Conjunto perfil superior corredero /  
 corredero + vidrio fijo **BLOQ FT a dintel**.  
 Montaje a falso techo.



100x66 mm

Acabado	Cód.		
MF	0 113 25	2 m	1 juego
	0 113 35	3 m	
	0 113 45	4 m	
	0 113 65	6 m	
S	0 112 27	2 m	
	0 112 37	3 m	
	0 112 47	4 m	
	0 112 67	6 m	
WL	0 112 28	2 m	
	0 112 38	3 m	
	0 112 48	4 m	
	0 112 68	6 m	
BL	0 112 29	2 m	
	0 112 39	3 m	
	0 112 49	4 m	
	0 112 69	6 m	

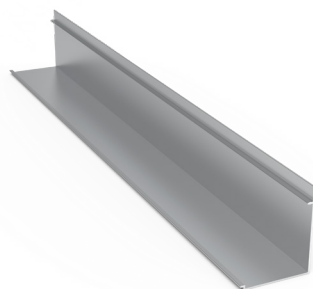

Tapeta **BLOQ Cube**.



55x66 mm

MF	0 113 36		3 m	2 perfiles
S	0 113 30			
WL	0 113 31			
BL	0 113 32			

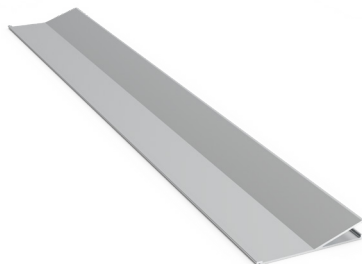

Tapeta **BLOQ Cube FT / FT a dintel**



73x13 mm

MF	0 113 37		3 m	2 perfiles
S	0 113 38			
WL	0 113 39			
BL	0 114 30			

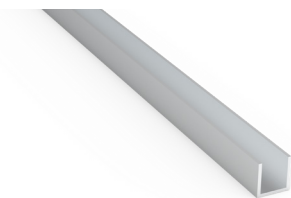

Perfil inferior para vidrio fijo de 8-10-12mm



20x20 mm

S	00 87 15	1,5 m	2 perfiles
	00 87 30	3 m	
	00 87 60	6 m	
WL	00 88 15	1,5 m	
	00 88 30	3 m	
	00 88 60	6 m	
BL	00 89 15	1,5 m	
	00 89 30	3 m	
	00 89 60	6 m	

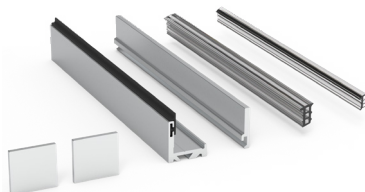

Perfil inferior entrada frontal para vidrio fijo de  
 8-10-12 mm



21x20 mm

S	0 110 32 <sup>1</sup>		3 m	1 juego
WL	0 110 34 <sup>1</sup>			
BL	0 110 35 <sup>1</sup>			

<sup>1</sup>El perfil incluye junta + juegos de tapas laterales. 2 m - 2 juegos de tapas 3 m - 4 juegos de tapas 6 m - 6 juegos de tapas

## /Juegos

Acabado

Cód.

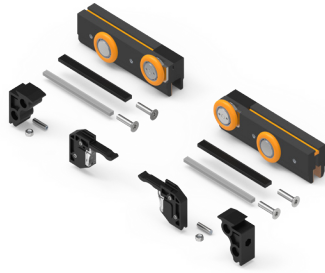
Juego accesorios **SV-Q60**. x2 Freno retenedor

60kg

RODAMIENTO  
A BOLAS

00 62 01

1 juego

Juego accesorios **SV-Q60**. x1 SofTop doble

60kg

RODAMIENTO  
A BOLAS

00 62 02

1 juego

Juego accesorios **SV-Q110**. x2 Freno retenedor

110kg

RODAMIENTO  
A BOLAS

0 110 01

1 juego

Juego accesorios **SV-Q110**. x1 SofTop doble









110kg

RODAMIENTO  
A BOLAS

0 110 02

1 juego

/Accesorios

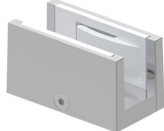
		Acabado	Cód.		
	Juego de tapas conjunto para perfil superior. Montaje a techo o pared.  73x66 mm	SP BP WP	00 70 74 00 70 76 00 70 75		1 juego
	SofTop doble <b>SV-Q60</b> 60kg		00 62 03		1 pieza
	SofTop doble <b>SV-Q110</b> 110kg		0 110 03		1 pieza
	Clip tapeta perfil superior <b>BLOQ</b> Ya incluido en juego de perfilera.		0 112 02		10 piezas
	Conector guías <b>SV-Q60 / SV-Q110</b>		0 112 01		1 pieza
	Soporte para pared de vidrio		00 70 84 <sup>1</sup>		10 piezas
	Junta transparente PVC  2x8mm 3x11mm 4x11mm	PVCT PVCB	00 45 82 (2mm) 00 45 87 (3mm) 00 45 84 (4mm) 00 45 83 (2mm) 00 45 90 (3mm) 00 45 85 (4mm)		1 pieza
	Guiador inferior para vidrio de 8-14mm	S WL BA	0 155 73 00 71 90 00 71 80		1 pieza

<sup>1</sup>Para las familias que incorporen soporte pared con perfilera de 2 m, 3 m, 4 m o 6 m, aplicar cada 400mm | <sup>1</sup>For sets that incorporate a wall support with 2 m, 3 m, 4 m or 6 m profiling, apply every 400 mm | <sup>1</sup>Pour les familles intégrant un support mural avec huisserie de 2 m, 3 m, 4 m ou 6 m, appliquer tous les 400 mm. 2 m - 6 soportes pared | supports wall | supports muraux 3 m - 8 soportes pared | supports wall | supports muraux 4 m - 10 soportes pared | supports wall | supports muraux 6 m - 15 soportes pared | supports wall | supports muraux

## /Kits

Acabado

Cód.



Kit **SV-Q60**. x2 Freno retenedor  
Con o sin vidrio fijo.

60kg por hoja



73x66 mm

RODAMIENTO  
A BOLAS0 912 01  
0 912 022 m  
3 m0 912 03  
0 912 042 m  
3 m

1 kit

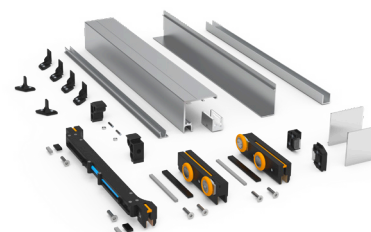
0 912 05  
0 912 062 m  
3 m

Kit **SV-Q60**. x1 SofTop doble  
Con o sin vidrio fijo.

60kg por hoja



73x66 mm

RODAMIENTO  
A BOLAS0 912 07  
0 912 082 m  
3 m0 912 09  
0 912 102 m  
3 m

1 kit

0 912 11  
0 912 132 m  
3 m

22



Kit **SV-Q110**. x2 Freno retenedor  
Con o sin vidrio fijo.

110kg por hoja



73x66 mm

RODAMIENTO  
A BOLAS0 912 14  
0 912 152 m  
3 m0 912 16  
0 912 172 m  
3 m

1 kit

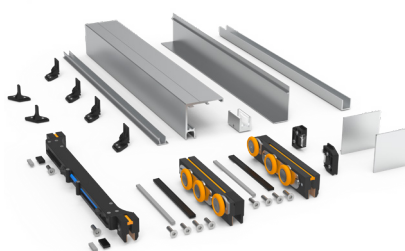
0 912 18  
0 912 192 m  
3 m

Kit **SV-Q110**. x1 SofTop doble  
Con o sin vidrio fijo.

110kg por hoja



73x66 mm

RODAMIENTO  
A BOLAS0 912 20  
0 912 212 m  
3 m0 912 22  
0 912 232 m  
3 m

1 kit

0 912 24  
0 912 252 m  
3 m



## **Compact Glass**

SV-X70

# COMPACT GLASS

BIBLIOTECA  
DE DESCARGAS



DOWNLOADS LIBRARY |  
BIBLIOTHÈQUE  
TÉLÉCHARGEMENTS

## ES

SV-X70 es un sistema de puerta corredera para paneles de vidrio sin marco que combina las últimas novedades tecnológicas con un atractivo diseño minimalista. El sistema se instala fácil y rápidamente, y es especialmente apropiado para aplicaciones domésticas y comerciales, en las que se integra a la perfección en cualquier diseño.

Este producto ofrece el sistema de frenado con softbrake. Proporcionando así una acción deslizante suave, agradable y segura: los dedos quedan resguardados en el ciclo de cierre del panel de vidrio, y éste también está protegido de daños de impacto.

SV-X70 Oculta todos sus mecanismos dentro del perfil superior consiguiendo un moderno y minimalista aspecto estético. Este sistema se ofrece tanto para montaje a techo como para montaje a pared. Para las instalaciones de montaje a pared, presenta una característica única en que la distancia entre la pared y el panel de vidrio se puede ajustar entre un mínimo de 14mm hasta 25mm, dependiendo de los requisitos de diseño, añadiendo así una mayor versatilidad para los demás beneficios del sistema.

## EN

SV-X70 is a compact sliding solution for frameless glass panels, combining latest technology with an attractive minimalist design. The system is quick and easy to install, and is particularly appropriate for domestic and commercial applications, where it integrates seamlessly into any design.

This product offers the softbrake system, thereby providing an advanced and pleasing sliding action, whilst at the same time enhancing safety; fingers are protected from being caught in the closing cycle of the glass panel, which itself is also protected from impact damage.

SV-X70 conceals all of its sliding components within the top track, giving a pleasing aesthetic appearance. SV-X70 is offered for both ceiling and wall mounted applications; for wall mounted installations, the system offers a unique feature, in that the distance between the wall and the glass panel can be adjusted between a minimal 14mm up to 25mm depending on design requirements, thereby adding a useful versatility to the other benefits of the system.

## FR

SV-X70 est un système de porte coulissante pour panneaux en verre sans cadre qui combine les dernières technologies avec un attrayant-désign minimaliste. Le système a une installation facile et rapide et il est particulièrement adapté pour les applications domestiques et commerciales, et parfaitement bien intègre dans toute conception.

Ce produit offre le système de freinage Softbrake, fournissant ainsi une action de glissement fluide, agréable et sécuritaire: les doigts sont protégés dans le cycle de fermeture du panneau de verre, et ces derniers le sont également contre les chocs.

SV-X70 il cache tous ses mécanismes dans le profil supérieur avec une esthétique moderne et minimaliste. Ce système est disponible pour le montage au plafond et pour le montage mural. Pour le montage des installations de mur, il a une caractéristique unique en ce que la distance entre le mur et le panneau de verre peut être réglée entre un minimum de 14mm à 25mm, selon les exigences de la installation, ajoutant ainsi une plus grande polyvalence aux avantages de ce système.





## Características técnicas

Technical characteristics | Caractéristiques techniques

### Perfilería Profiles | Profils

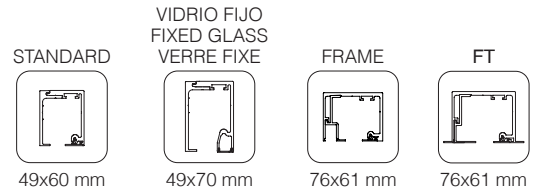

### FT VIDRIO FIJO I FIXED GLASS I VERRE FIXE

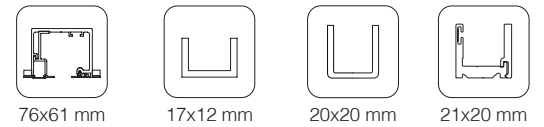

### Especificaciones Specifications | Spécification



8-10 mm



**2 Softbrake**  
MÍN. 675mm



KIT DISPONIBLE  
I AVAILABLE



RODAMIENTO A BOLAS  
BALL BEARING  
ROULEMENT À BILLES



SOFTBRAKE  
MÁX. 70Kg

### Peso Weight | Poids



### Producto certificado

Certificated product | Produit certifié



**Variantes de instalación**

Installation possibilities | Variantes d'installation

**PARED**  
WALL  
MUR

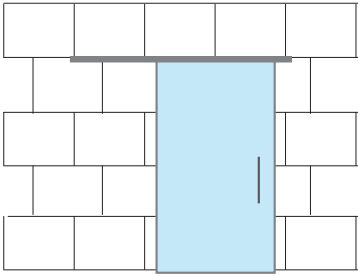

**PARED CON VIDRIO FJO**  
WALL WITH FIXED PANEL  
MUR AVEC VERRE FIXE

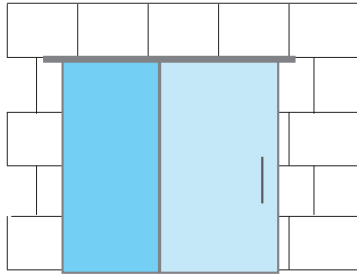

**TECHO**  
CEILING  
PLAFOND

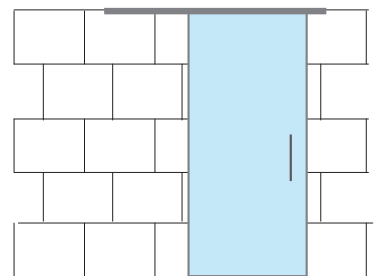

**TECHO CON VIDRIO FJO**  
CEILING WITH FIXED PANEL  
PLAFOND AVEC VERRE FIXE

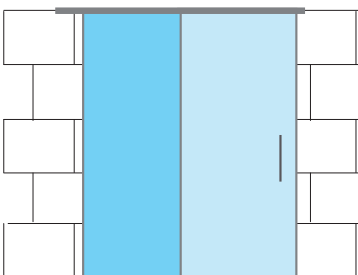

**FALSO TECHO**  
FALSE CEILING  
FAUX PLAFOND

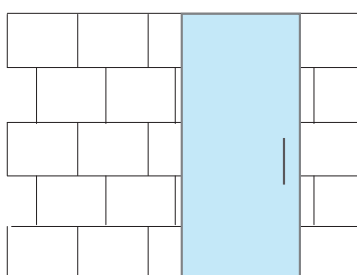

**FALSO TECHO CON VIDRIO FJO**  
FALSE CEILING WITH FIXED PANEL  
FAUX PLAFOND AVEC VERRE FIXE

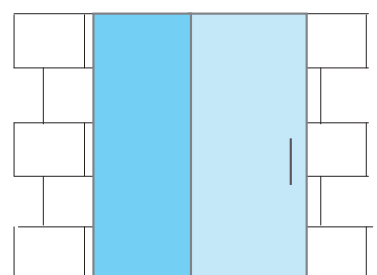

**PARED DE VIDRIO**  
GLASS WALL  
MUR DE VERRE

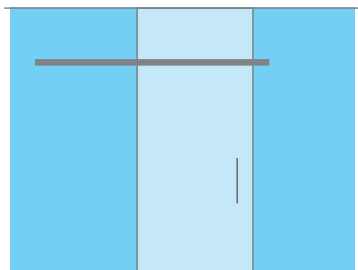

**TECHO CON VIDRIO FJO**  
CEILING WITH FIXED PANEL  
PLAFOND AVEC VERRE FIXE

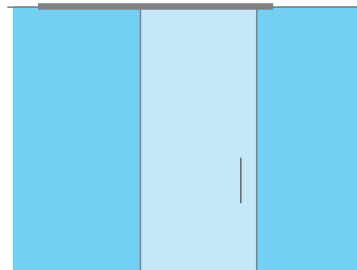

**FALSO TECHO CON VIDRIO FJO**  
FALSE CEILING WITH FIXED PANEL  
FAUX PLAFOND AVEC VERRE FIXE

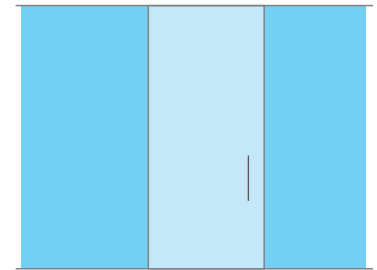

 **PUERTA CORREDERA** | SLIDING DOOR | PORTE COULISSANTE

 **VIDRIO FIJO** | FIXED GLASS | VERRE FIXE



## Sección tipo

Cros-section | Section type (Cotas en mm | Dimensions in mm | Dimensions en mm)

### MONTAJE A PARED | WALL MOUNTING | FIXATION À MUR

Tornillo | Screw | Vis  
DIN-7505 4,5x40mm

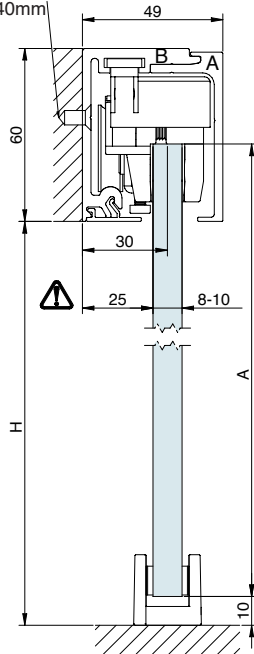

$$A = H + 17$$

PARED DE VIDRIO  
GLASS WALL | MUR DE VERRE

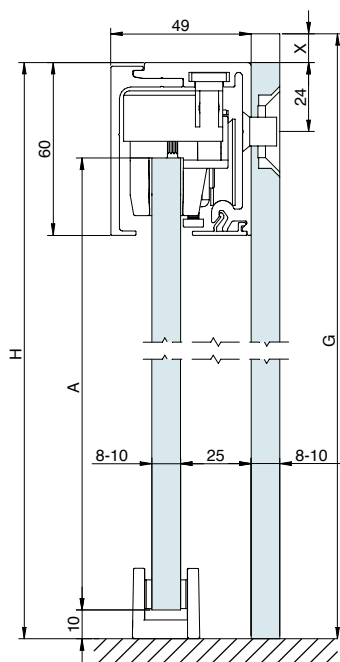

$$A = H - 43$$

$$G = H + X$$

**Sección tipo**

Cross-section | Section type (Cotas en mm | Dimensions in mm | Dimensions en mm)

**MONTAJE A TECHO** | CEILING MOUNTING | FIXATION À PLAFOND

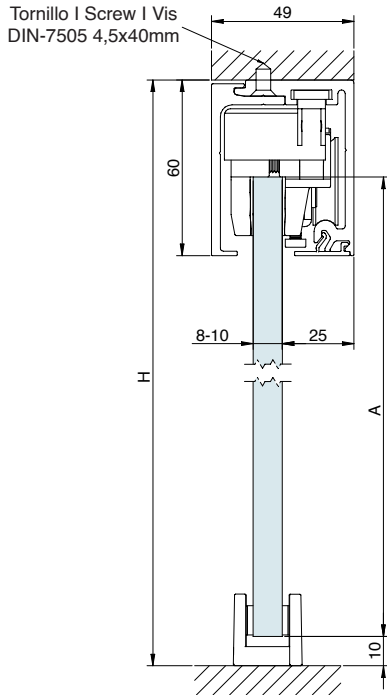

A= H-43

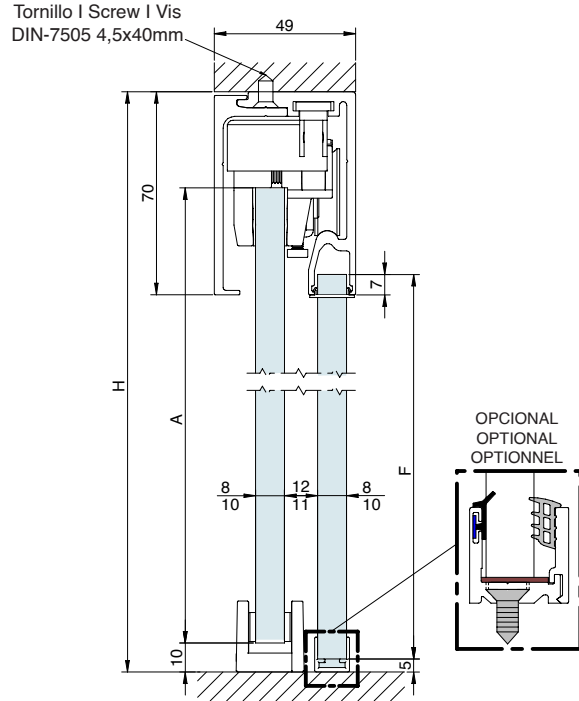

A= H-43

F= H-67

**MONTAJE A FALSO TECHO** | FALSE CEILING MOUNTING | FIXATION À FAUX-PLAFOND

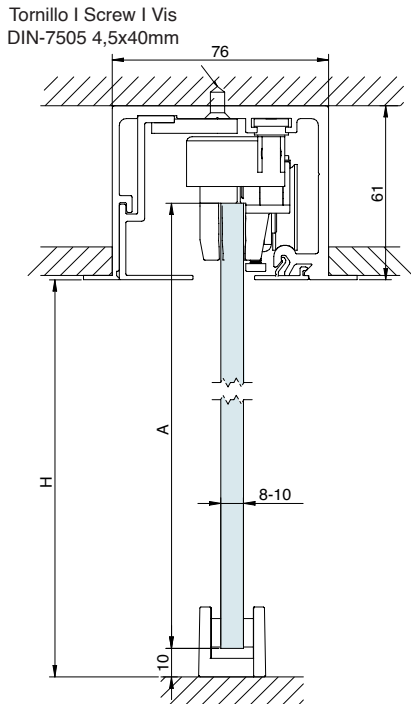

A= H+17

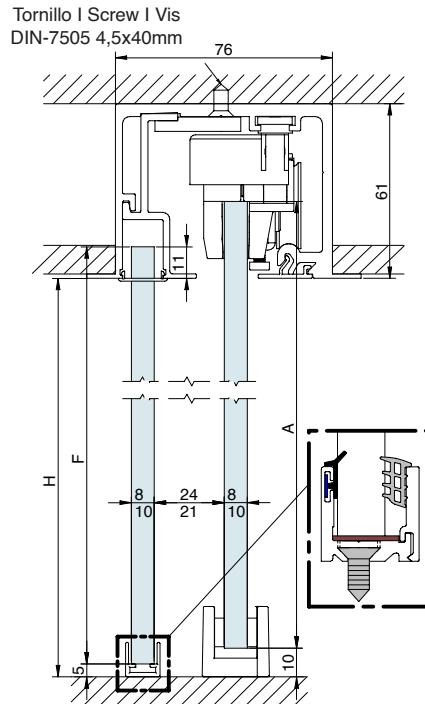







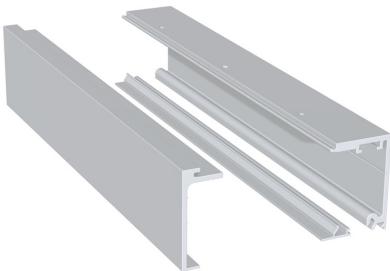

A= H+17

F= H+6



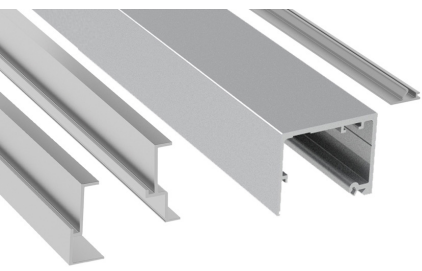

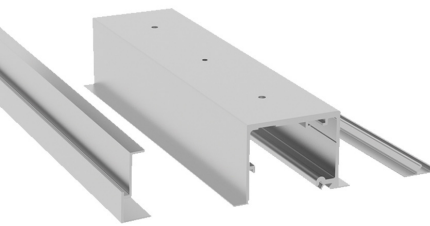



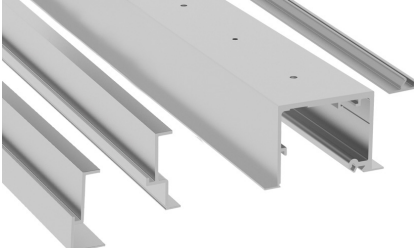

Componentes

Components | Composants

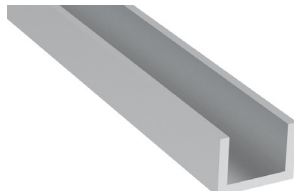
PERFILERÍA   PROFILES   PROFILS		Acabado	Cód.		
 <p>Conjunto perfil superior corredero Sliding top track set Jeu rail supérieur coulissant</p>  <p>49x60mm</p>	<p>S</p> <p>WL</p> <p>BL</p>	<p>00 70 20</p> <p>00 70 30</p> <p>00 70 50</p>	<p>2 m</p> <p>3 m</p> <p>5 m</p>	<p>1 juego</p> <p>1 set</p> <p>1 jeu</p>	
		<p>00 71 20</p> <p>00 71 30</p> <p>00 71 50</p>	<p>2 m</p> <p>3 m</p> <p>5 m</p>		
		<p>00 71 24</p> <p>00 71 34</p> <p>00 71 54</p>	<p>2 m</p> <p>3 m</p> <p>5 m</p>		
 <p>Conjunto perfil superior corredero para vidrio fijo Sliding top track set for fixed glass Jeu rail supérieur coulissant pour verre fixe</p>  <p>49x70mm</p>	<p>S</p> <p>WL</p> <p>BL</p>	<p>00 70 26</p> <p>00 70 36</p> <p>00 70 56</p>	<p>2 m</p> <p>3 m</p> <p>5 m</p>	<p>1 juego</p> <p>1 set</p> <p>1 jeu</p>	
		<p>00 71 21</p> <p>00 71 31</p> <p>00 71 51</p>	<p>2 m</p> <p>3 m</p> <p>5 m</p>		
		<p>00 71 25</p> <p>00 71 35</p> <p>00 71 55</p>	<p>2 m</p> <p>3 m</p> <p>5 m</p>		
 <p>Conjunto perfil superior corredero <b>para accesorio Frame</b> Sliding top track set for Frame accessory Jeu rail supérieur coulissant pour accessoire Frame</p>  <p>76x61mm</p>	<p>S</p> <p>WL</p> <p>BL</p>	<p>0 109 86</p> <p>0 109 87</p> <p>0 109 88</p> <p>0 109 89</p>	<p>2 m</p> <p>3 m</p> <p>4 m</p> <p>6 m</p>	<p>1 juego</p> <p>1 set</p> <p>1 jeu</p>	
		<p>0 111 86</p> <p>0 111 87</p> <p>0 111 88</p> <p>0 111 89</p>	<p>2 m</p> <p>3 m</p> <p>4 m</p> <p>6 m</p>		
		<p>0 109 94</p> <p>0 109 95</p> <p>0 109 96</p> <p>0 109 97</p>	<p>2 m</p> <p>3 m</p> <p>4 m</p> <p>6 m</p>		
 <p>Conjunto perfil superior corredero <b>FT</b>. Montaje a falso techo. FT sliding top track set. False ceiling mounting. Set rail supérieur coulissant FT. Fixation à faux plafond.</p>  <p>76x61mm</p>	<p>S</p> <p>WL</p> <p>BL</p>	<p>0 109 24</p> <p>0 109 34</p> <p>0 109 44</p> <p>0 109 64</p>	<p>2 m</p> <p>3 m</p> <p>4 m</p> <p>6 m</p>	<p>1 juego</p> <p>1 set</p> <p>1 jeu</p>	
		<p>0 119 22</p> <p>0 119 32</p> <p>0 119 42</p> <p>0 119 62</p>	<p>2 m</p> <p>3 m</p> <p>4 m</p> <p>6 m</p>		
		<p>0 119 26</p> <p>0 119 36</p> <p>0 119 46</p> <p>0 119 66</p>	<p>2 m</p> <p>3 m</p> <p>4 m</p> <p>6 m</p>		

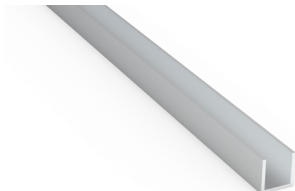
## Componentes

Components | Composants

PERFILERÍA   PROFILES   PROFILS	Acabado	Cód.		
 <p>Conjunto perfil superior corredero <b>FT</b> para vidrio fijo. Montaje a falso techo FT sliding top track for fixed glass set. False ceiling mounting Set rail supérieur coulissant pour verre fixe. Fixation à faux plafond.</p>  <p>76x61mm</p>	<p><b>S</b></p> <p><b>WL</b></p> <p><b>BL</b></p>	<p>0 109 26 0 109 36 0 109 46 0 109 66</p> <p>0 119 23 0 119 33 0 119 43 0 119 63</p> <p>0 119 27 0 119 37 0 119 47 0 119 67</p>	<p>2 m 3 m 4 m 6 m</p> <p>2 m 3 m 4 m 6 m</p> <p>2 m 3 m 4 m 6 m</p>	<p>1 juego 1 set 1 jeu</p>
 <p>Perfil inferior para vidrio fijo de 8-10-12mm Bottom track for fixed glass of 8-10-12mm Rail inférieur pour verre fixe de 8-10-12mm</p>  <p>17x12mm</p>	<p><b>S</b></p> <p><b>WL</b></p> <p><b>BL</b></p>	<p>00 87 34</p> <p>00 71 91</p> <p>00 71 81</p>	<p>3 m</p>	<p>1 perfil 1 profile 1 profil</p>
 <p>Perfil inferior para vidrio fijo de 8-10-12mm</p>  <p>20x20 mm</p>	<p><b>S</b></p> <p><b>WL</b></p> <p><b>BL</b></p>	<p>00 87 15 00 87 30 00 87 60</p> <p>00 88 15 00 88 30 00 88 60</p> <p>00 89 15 00 89 30 00 89 60</p>	<p>1,5 m 3 m 6 m</p> <p>1,5 m 3 m 6 m</p> <p>1,5 m 3 m 6 m</p>	<p>2 perfiles</p>
 <p>Perfil inferior entrada frontal para vidrio fijo de 8-10-12 mm Inferior rail front entry for fixed glass of 8-10-12mm Profil inférieur entrée frontale pour verre fixe de 8-10-12mm</p>  <p>21x20mm</p>	<p><b>S</b></p> <p><b>WL</b></p> <p><b>BL</b></p>	<p>0 110 32<sup>1</sup></p> <p>0 110 34<sup>1</sup></p> <p>0 110 35<sup>1</sup></p>	<p>3 m</p>	<p>1 juego 1 set 1 jeu</p>

<sup>1</sup>El perfil incluye junta + juegos de tapas laterales | <sup>1</sup>This profile includes PVC joints + set of end caps | <sup>1</sup>Le profil inclue jointes plastiques + capuchons finals

2 m - 2 juegos de tapas | 2 set of caps | 2 set de caupuchons finals 3 m - 4 juegos de tapas | 4 set of caps | 4 set de caupuchons finals 6 m - 6 juegos de tapas | 6 set of caps | 6 set de caupuchons finals

**S** Aluminio anodizado plata mate  
Satin anodized aluminium  
Aluminium anodisé argent





**WL** Aluminio lacado blanco mate  
Matt white lacquered aluminium  
Aluminium anodisé laqué blanc mat

**BL** Aluminio lacado negro mate  
Matt black lacquered aluminium  
Aluminium anodisé laqué noir mat

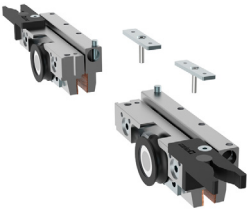

Componentes

Components | Composants

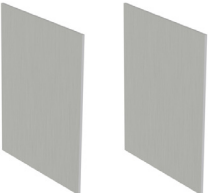
JUEGOS   SETS   JEUX		Acabado	Cód.		
 <p>Juego accesorios <b>SV-X70</b> x2 Sotbrake SV-X70 Fitting set x2 Softbrake Garniture SV-X70 x2 Amortisseur</p> <p>70kg por hoja   per panel   par panneau</p>  <p>RODAMIENTO A BOLAS BALL BEARING ROULEMENT À BILLES</p>			00 70 01		1 juego 1 set 1 jeu
 <p>Juego accesorios <b>SV-X70</b> x2 Freno retenedor SV-X70 Fitting set x2 Retaining stopper Garniture SV-X70 x2 Frein de retenue</p> <p>70kg por hoja   per panel   par panneau</p>  <p>RODAMIENTO A BOLAS BALL BEARING ROULEMENT À BILLES</p>			00 70 05		1 juego 1 set 1 jeu
ACCESORIOS   ACCESSORIES   ACCESSOIRES		Acabado	Cód.		
 <p>Juego de tapas para perfil superior. Montaje a techo o pared. End cover set for top track. Ceiling and wall mounting. Jeu de capuchons finals pour rail supérieur. Fixation à mur et à plafond.</p>	<p><b>S</b></p> <p><b>WL</b></p> <p><b>BL</b></p>		00 70 70 00 71 93 00 71 83		1 juego 1 set 1 jeu

## Componentes

Components | Composants

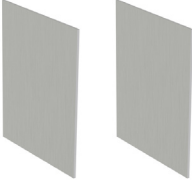
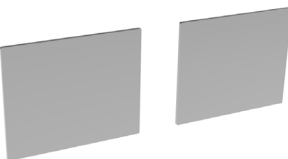
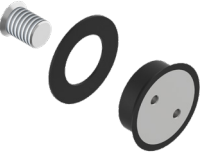
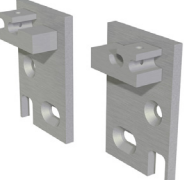

ACCESORIOS   ACCESSORIES   ACCESSOIRES		Acabado	Cód.		
	<p>Juego de tapas para perfil superior con vidrio fijo. Montaje a techo o pared End cover set for top track with fixed glass. Ceiling and wall mounting Jeu de capuchons finals pour profil supérieur avec verre fixe. Fixation à mur et à plafond</p>	<b>S</b>	00 70 71		1 juego 1 set 1 jeu
		<b>WL</b>	00 71 94		
		<b>BL</b>	00 71 84		
	<p>Juego de tapas laterales para perfil superior <b>para accesorio Frame</b>. Montaje a techo Lateral cap set for top track for accessory Frame. Ceiling mounting Jeu de capuchons latéraux pour rail supérieur pour accessoire Frame. Fixation à plafond.</p>	<b>S</b>	00 70 78		1 juego 1 set 1 jeu
		<b>WL</b>	00 70 77		
		<b>BL</b>	00 70 79		
	<p>Soporte para pared de vidrio Glass wall support Support mur pour installation sur verre</p>		00 70 84 <sup>1</sup>		10 piezas 10 pièces 10 pièces
	<p>Juego soporte flotante Set of end wall track brackets Jeu supports murales pour rail porteur</p>	<b>S</b>	00 70 80		1 juego 1 set 1 jeu
		<b>WL</b>	00 71 95		
		<b>BA</b>	00 71 85		

<sup>1</sup>Para las familias que incorporen soporte pared con perfilera de 2 m, 3 m, 4 m o 6 m, aplicar cada 400mm | <sup>1</sup>For sets that incorporate a wall support with 2 m, 3 m, 4 m or 6 m profiling, apply every 400 mm | <sup>1</sup>Pour les familles intégrant un support mural avec huisserie de 2 m, 3m, 4 m ou 6 m, appliquer tous les 400 mm. 2 m - 6 soportes pared | supports wall | supports muraux 3 m - 8 soportes pared | supports wall | supports muraux 4 m - 10 soportes pared | supports wall | supports muraux 6 m - 15 soportes pared | supports wall | supports muraux

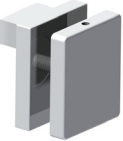
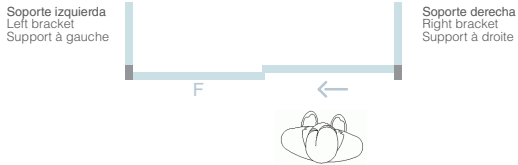

Componentes

Components | Composants

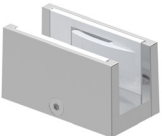
ACCESORIOS   ACCESSORIES   ACCESSOIRES		Acabado	Cód.		
	<p>Juego soporte flotante (Montaje enrasado) Set of end wall track brackets (Leveled assembly) Jeu supports murales pour rail porteur (Mountage arasé)</p>	GI	00 70 87		1 juego 1 set 1 jeu
	<p>Soporte flotante vidrio Mounting bracket on glass Support de montage sur verre</p> 	<p>S</p> <p>WL</p> <p>BA</p> <p>S</p> <p>WL</p> <p>BA</p>	<p>0 972 02</p> <p>0 972 07</p> <p>0 972 08</p> <p>0 972 05</p> <p>0 972 09</p> <p>0 972 10</p>	<p>Izquierda Left À gauche</p> <p>Derecha Right Droite</p>	1 unidad 1 unit 1 unité
	<p>Tornillería sujeción 1 metro de perfil Bolts for securing 1 metre of track Vis de fixation 1 mètre de profil</p>		0 160 73		1 juego 1 set 1 jeu
	<p>Guiador inferior para vidrio de 8-14mm Bottom guide for glass of 8-14mm Guide inférieur pour verre de 8-14mm</p>	<p>S</p> <p>WL</p> <p>BA</p>	<p>0 155 73</p> <p>00 71 90</p> <p>00 71 80</p>		1 pieza 1 piece 1 pièce

GI Hierro cincado  
Galvanized iron  
Fer zingué







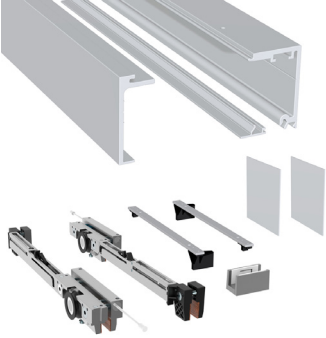

S Aluminio anodizado plata mate  
Satin anodized aluminium  
Aluminium anodisé argent

WL Aluminio lacado blanco mate  
Matt white lacquered aluminium  
Aluminium anodisé laqué blanc mat

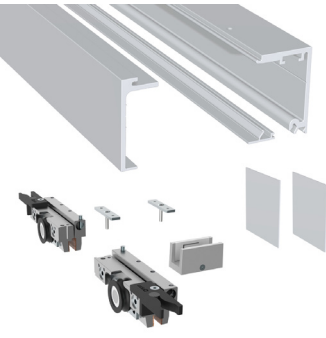
BA Aluminio anodizado negro  
Black anodized aluminium  
Aluminium anodisé noir

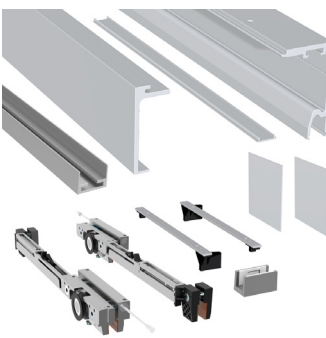
**Componentes**

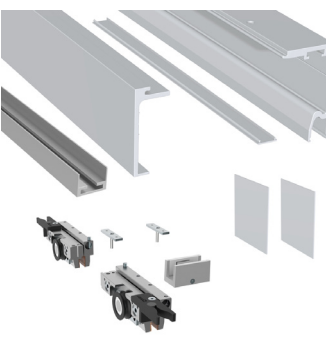
Components | Composants

KITS   KITS   KITS		Acabado	Cód.		
 <p>Kit <b>SV-X70</b> x2 Softbrake                      SV-X70 kit x2 Softbrake                      Kit SV-X70 x2 Amortisseur</p> <p>70kg por hoja   per panel   par panneaux</p>  49x60mm  RODAMIENTO A BOLAS BALL BEARING ROULEMENT À BILLES	<b>S</b>	0 970 01 0 970 02	2 m 3 m	1 kit 1 jeu	
	<b>BL</b>	0 970 70 0 970 71	2 m 3 m		
 <p>Kit <b>SV-X70</b> x2 Freno retenedor                      SV-X70 kit x2 Retaining stopper                      Kit SV-X70 x2 Freins de retenue</p> <p>70kg por hoja   per panel   par panneaux</p>  49x60mm  RODAMIENTO A BOLAS BALL BEARING ROULEMENT À BILLES	<b>S</b>	0 970 33 0 970 34	2 m 3 m	1 kit 1 jeu	
	<b>BL</b>	0 970 72 0 970 73	2 m 3 m		
 <p>Kit <b>SV-X70</b> para vidrio fijo x2 Softbrake                      SV-X70 kit for fixed glass x2 Softbrake                      Kit SV-X70 pour verre fixe x2 Amortisseur</p> <p>70kg por hoja   per panel   par panneaux</p>  49x70mm  RODAMIENTO A BOLAS BALL BEARING ROULEMENT À BILLES	<b>S</b>	0 970 41 0 970 42	2 m 3 m	1 kit 1 jeu	
	<b>BL</b>	0 970 74 0 970 75	2 m 3 m		
 <p>Kit <b>SV-X70</b> para vidrio fijo x2 Freno retenedor                      SV-X70 kit for fixed glass x2 Retaining stopper                      Kit SV-X70 pour verre fixe x2 Frein de retenue</p> <p>70kg por hoja   per panel   par panneaux</p>  49x70mm  RODAMIENTO A BOLAS BALL BEARING ROULEMENT À BILLES	<b>S</b>	0 970 57 0 970 58	2 m 3 m	1 kit 1 jeu	
	<b>BL</b>	0 970 76 0 970 77	2 m 3 m		



# Compact Glass

SV-X110

# COMPACT GLASS

BIBLIOTECA  
DE DESCARGAS



DOWNLOADS LIBRARY |  
BIBLIOTHÈQUE  
TÉLÉCHARGEMENTS

## ES

SV-X110 es un sistema de puerta corredera para paneles de vidrio sin marco que combina las últimas novedades tecnológicas con un atractivo diseño minimalista. El sistema se instala fácil y rápidamente, y es especialmente apropiado para aplicaciones domésticas y comerciales, en las que se integra a la perfección en cualquier diseño.

Este producto permite elegir entre distintos sistemas de frenado: Anti-shock, Freno retenedor y el novedoso sistema **SOFTPRO**, una solución única en el mercado para el frenado suave de puertas correderas. Éste sistema proporciona una acción deslizante suave, agradable y segura: los dedos quedan resguardados en el ciclo de cierre del panel de vidrio, y éste también está protegido de daños de impacto.

## EN

SV-X110 is a compact sliding solution for frameless glass panels, combining latest technology with an attractive minimalist design. The system is quick and easy to install, and is particularly appropriate for domestic and commercial applications, where it integrates seamlessly into any design.

There is a choice between different braking systems: anti-shock, retaining brake and our new **SOFTPRO** system, an exceptional solution for a smooth and quiet sliding action with an effective, powerful yet at the same time gentle soft closing and or opening action. In this way a pleasing aesthetic performance is combined with enhanced safety; fingers are protected from becoming trapped on the closing cycle of the glass panel, which itself is also protected from impact damage.

## FR

SV-X110 est un système de porte coulissante pour panneaux en verre sans cadre qui combine les dernières technologies avec un design minimaliste attrayant. Le système s'installe facile et rapidement et est particulièrement adapté pour les applications domestiques et commerciales, qui s'intègre de façon transparente dans toute conception.

Ce produit vous permet de choisir entre les différents systèmes de freinage: Anti-choc, le frein de retenue et le nouveau système **SOFTPRO**, une solution unique sur le marché pour les portes coulissantes de freinage doux. Ce système fournit une action de glissement lisse, agréable et sûr: les doigts sont à l'abri dans le cycle de fermeture du panneau de verre, et il est également protégé contre les chocs.



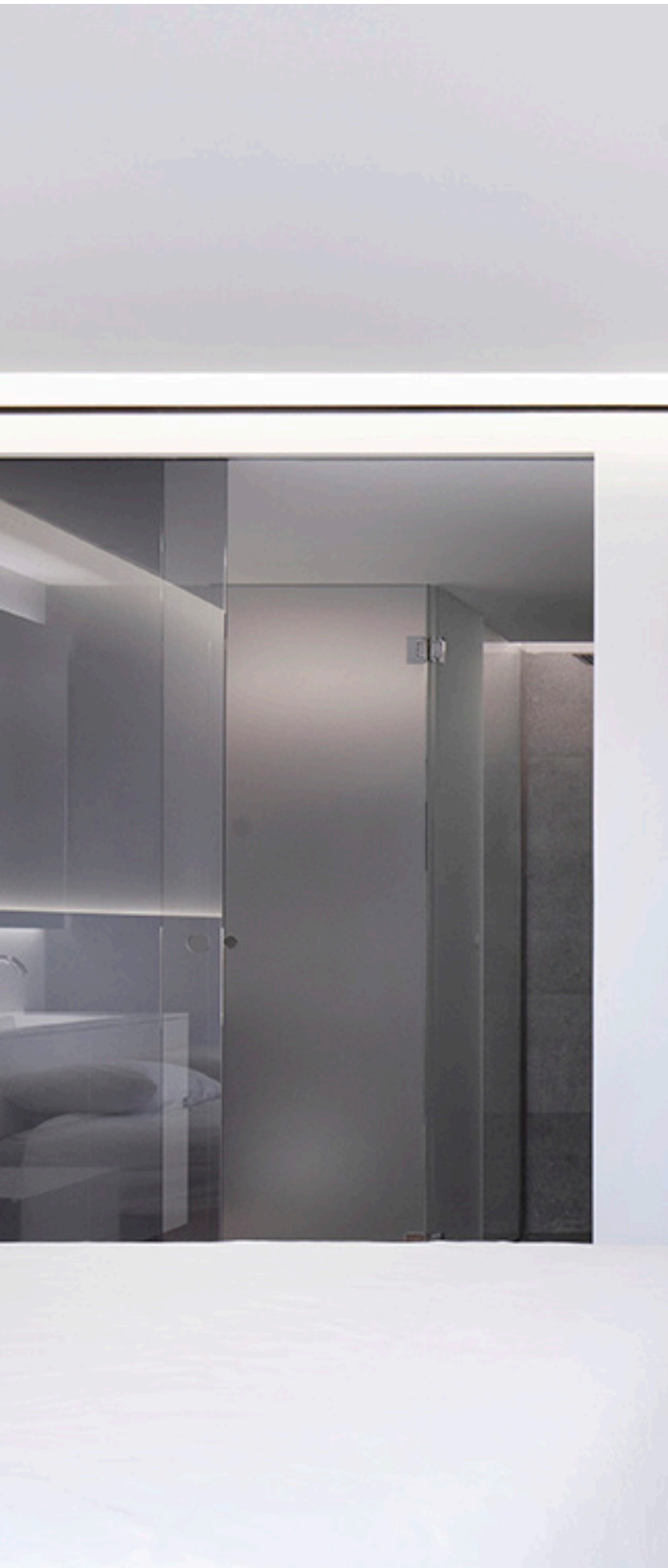

## Características técnicas

Technical characteristics | Caractéristiques techniques

### Perfilería Profiles | Profils

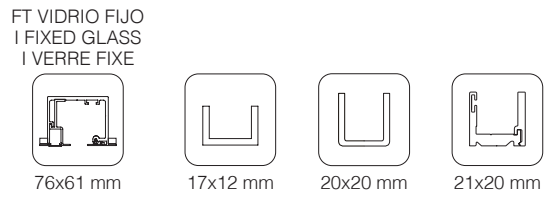
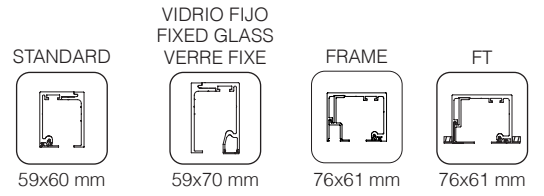

### Especificaciones Specifications | Spécification

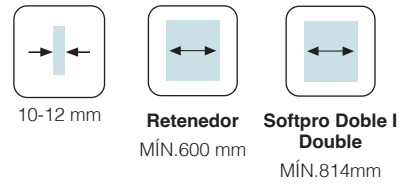

### Peso Weight | Poids



### Producto certificado

Certificated product | Produit certifié



**Variantes de instalación**

Installation possibilities | Variantes d'installation

**PARED**  
WALL  
MUR

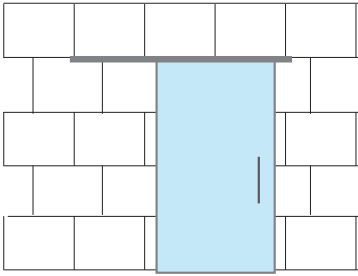

**PARED CON VIDRIO FJO**  
WALL WITH FIXED PANEL  
MUR AVEC VERRE FIXE

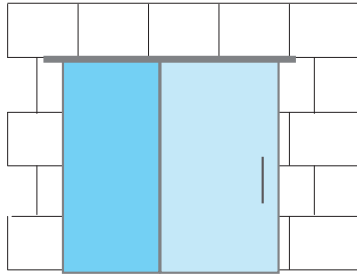

**TECHO**  
CEILING  
PLAFOND

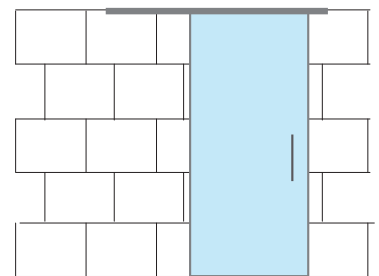

**TECHO CON VIDRIO FJO**  
CEILING WITH FIXED PANEL  
PLAFOND AVEC VERRE FIXE

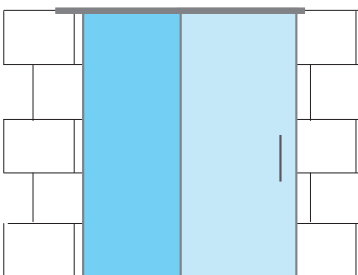

**FALSO TECHO**  
FALSE CEILING  
FAUX PLAFOND

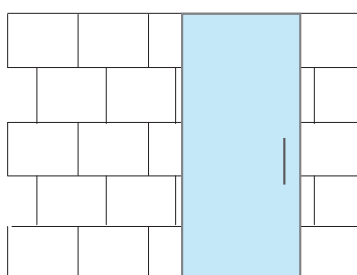

**FALSO TECHO CON VIDRIO FJO**  
FALSE CEILING WITH FIXED PANEL  
FAUX PLAFOND AVEC VERRE FIXE

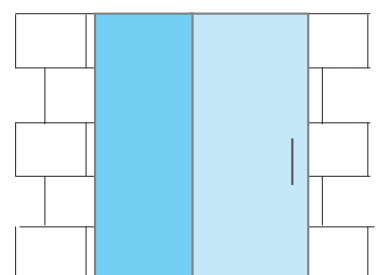

**PARED DE VIDRIO**  
GLASS WALL  
MUR DE VERRE

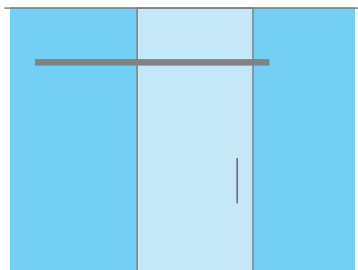

**TECHO CON VIDRIO FJO**  
CEILING WITH FIXED PANEL  
PLAFOND AVEC VERRE FIXE

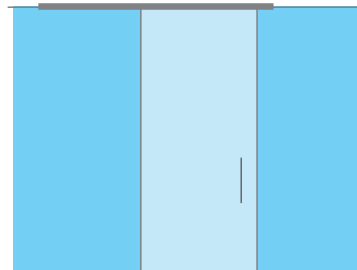

**FALSO TECHO CON VIDRIO FJO**  
FALSE CEILING WITH FIXED PANEL  
FAUX PLAFOND AVEC VERRE FIXE

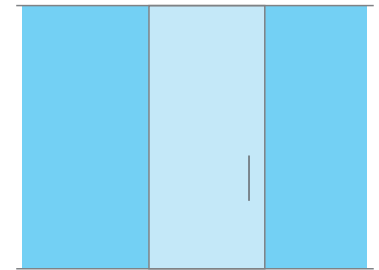

 **PUERTA CORREDERA** | SLIDING DOOR | PORTE COULISSANTE

 **VIDRIO FJO** | FIXED GLASS | VERRE FIXE

**Sección tipo**

Cross-section | Section type (Cotas en mm | Dimensions in mm | Dimensions en mm)

**MONTAJE A PARED | WALL MOUNTING | FIXATION À MUR**

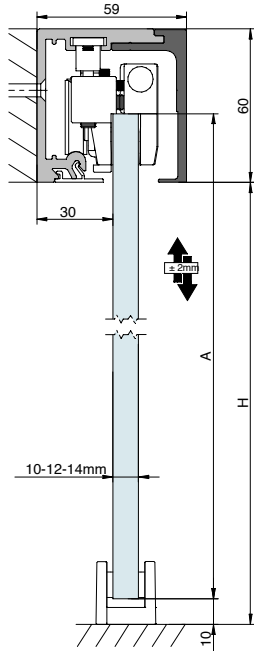

$A = H + 17$

**PARED DE VIDRIO**  
 GLASS WALL | MUR DE VERRE

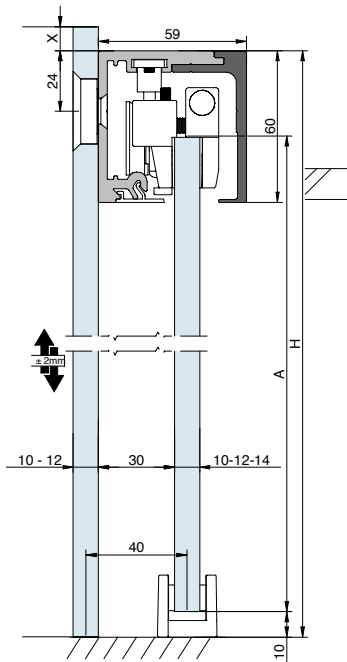

$A = H - 43$

$G = H + X$



Sección tipo

Cross-section | Section type (Cotas en mm | Dimensions in mm | Dimensions en mm)

MONTAJE A TECHO | CEILING MOUNTING | FIXATION À PLAFOND

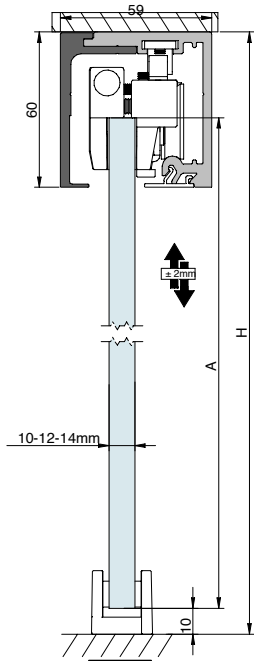

A= H-43

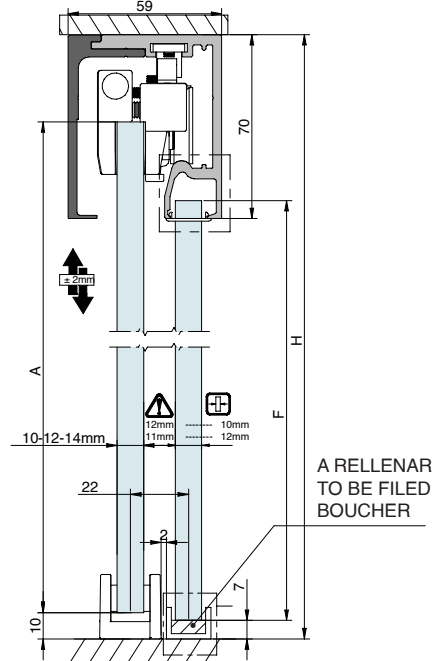

A= H-43

F= H-70

MONTAJE A FALSO TECHO | FALSE CEILING MOUNTING | FIXATION À FAUX-PLAFOND

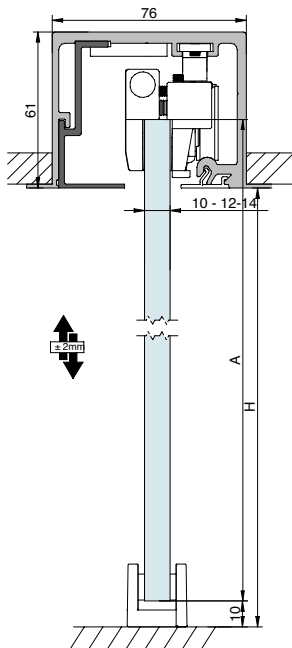

A= H+17

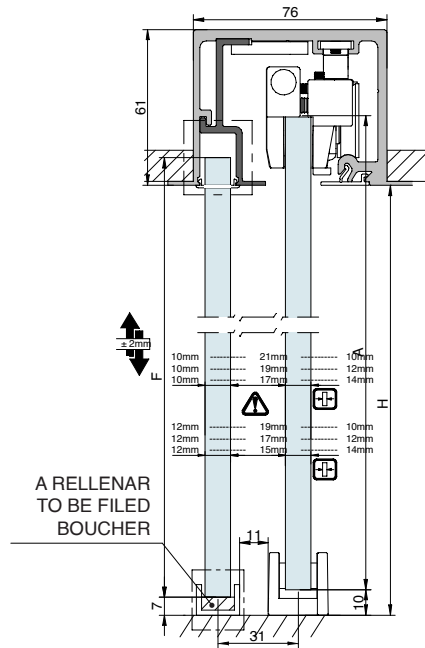





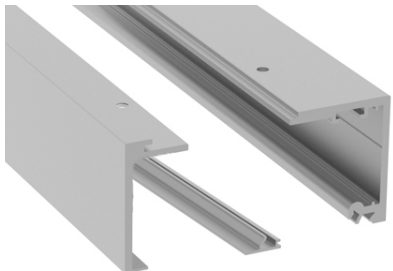

A= H+17

F= H+4

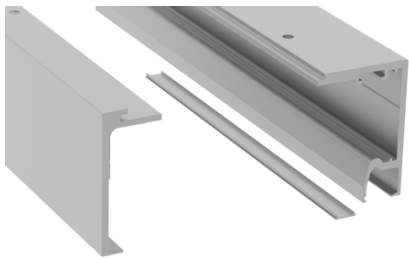
**Componentes**

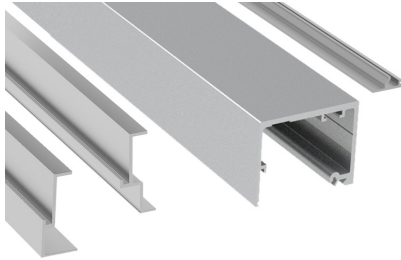
Components | Composants

PERFILERÍA   PROFILES   PROFILS	Acabado	Cód.		
 <p>Conjunto perfil superior corredero Sliding top track set Jeu rail supérieur coulissant</p>  <p>59x60mm</p>	<p><b>S</b></p> <p>0 109 20 0 109 30 0 109 40 0 109 60</p> <p><b>WL</b></p> <p>0 119 20 0 119 30 0 119 40 0 119 60</p> <p><b>BL</b></p> <p>0 119 24 0 119 34 0 119 44 0 119 64</p>	<p>2 m 3 m 4 m 6 m</p> <p>2 m 3 m 4 m 6 m</p> <p>2 m 3 m 4 m 6 m</p>	<p>1 juego 1 set 1 jeu</p>	
 <p>Conjunto perfil superior corredero para vidrio fijo Sliding top track set for fixed glass Jeu rail supérieur coulissant pour verre fixe</p>  <p>59x70mm</p>	<p><b>S</b></p> <p>0 109 22 0 109 32 0 109 42 0 109 62</p> <p><b>WL</b></p> <p>0 119 21 0 119 31 0 119 41 0 119 61</p> <p><b>BL</b></p> <p>0 119 25 0 119 35 0 119 45 0 119 65</p>	<p>2 m 3 m 4 m 6 m</p> <p>2 m 3 m 4 m 6 m</p> <p>2 m 3 m 4 m 6 m</p>	<p>1 juego 1 set 1 jeu</p>	
 <p>Conjunto perfil superior corredero <b>para accesorio</b> <b>Frame</b> Sliding top track set for Frame accessory Jeu rail supérieur coulissant pour accessoire Frame</p>  <p>76x61mm</p>	<p><b>S</b></p> <p>0 109 86 0 109 87 0 109 88 0 109 89</p> <p><b>WL</b></p> <p>0 111 86 0 111 87 0 111 88 0 111 89</p> <p><b>BL</b></p> <p>0 109 94 0 109 95 0 109 96 0 109 97</p>	<p>2 m 3 m 4 m 6 m</p> <p>2 m 3 m 4 m 6 m</p> <p>2 m 3 m 4 m 6 m</p>	<p>1 juego 1 set 1 jeu</p>	

**S** Aluminio anodizado plata mate  
Satin anodized aluminium  
Aluminium anodisé argent







**WL** Aluminio lacado blanco mate  
Matt white lacquered aluminium  
Aluminium anodisé laqué blanc mat

**BL** Aluminio lacado negro mate  
Matt black lacquered aluminium  
Aluminium anodisé laqué noir mat

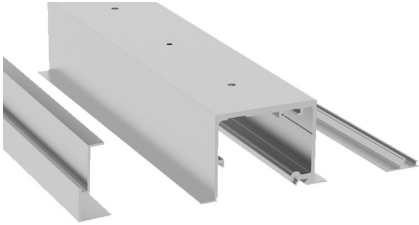

## Componentes

### Components | Composants

PERFILERÍA   PROFILES   PROFILS		Acabado	Cód.				
 <p>Conjunto perfil superior corredero <b>FT</b>. Montaje a falso techo            FT sliding top track set. False ceiling mounting            Set rail supérieur coulissant FT. Fixation à faux plafond</p>  <p>76x61mm</p>	<p>Conjunto perfil superior corredero <b>FT</b> para vidrio fijo. Montaje a falso techo            FT sliding top track for fixed glass set. False ceiling mounting            Set rail supérieur coulissant pour verre fixe. Fixation à faux plafond</p>  <p>76x61mm</p>	<p>Conjunto perfil superior corredero para vidrio fijo de 8-10-12mm            Bottom track for fixed glass of 8-10-12mm            Rail inférieur pour verre fixe de 8-10-12mm</p>  <p>17x12mm</p>	<p>Rail inférieur pour verre fixe 8-10-12mm</p>  <p>20x20 mm</p>	<p>Perfil inferior entrada frontal para vidrio fijo de 8-10-12 mm            Bottom track front entry for fixed glass of 8-10-12mm            Rail inférieur entrée frontale pour verre fixe de 8-10-12mm</p>  <p>21x20mm</p>	<p><b>S</b></p> <p>0 109 24 0 109 34 0 109 44 0 109 64</p> <p><b>WL</b></p> <p>0 119 22 0 119 32 0 119 42 0 119 62</p> <p><b>BL</b></p> <p>0 119 26 0 119 36 0 119 46 0 119 66</p>	<p>2 m 3 m 4 m 6 m</p> <p>2 m 3 m 4 m 6 m</p> <p>2 m 3 m 4 m 6 m</p> <p>2 m 3 m 4 m 6 m</p> <p>2 m 3 m 4 m 6 m</p> <p>2 m 3 m 4 m 6 m</p>	<p>1 juego 1 set 1 jeu</p> <p>1 juego 1 set 1 jeu</p> <p>1 perfil 1 profile 1 profil</p> <p>2 profils</p> <p>1 perfil 1 profile 1 profil</p>
					<p><b>S</b></p> <p>0 109 26 0 109 36 0 109 46 0 109 66</p> <p><b>WL</b></p> <p>0 119 23 0 119 33 0 119 43 0 119 63</p> <p><b>BL</b></p> <p>0 119 27 0 119 37 0 119 47 0 119 67</p>	<p>2 m 3 m 4 m 6 m</p> <p>2 m 3 m 4 m 6 m</p> <p>2 m 3 m 4 m 6 m</p>	<p>1 juego 1 set 1 jeu</p>
					<p><b>S</b></p> <p>00 87 34</p> <p><b>WL</b></p> <p>00 71 91</p> <p><b>BL</b></p> <p>00 71 81</p>	<p>3 m</p>	<p>1 perfil 1 profile 1 profil</p>
					<p><b>S</b></p> <p>00 87 15 00 87 30 00 87 60</p> <p><b>WL</b></p> <p>00 88 15 00 88 30 00 88 60</p> <p><b>BL</b></p> <p>00 89 15 00 89 30 00 89 60</p>	<p>1,5 m 3 m 6 m</p> <p>1,5 m 3 m 6 m</p> <p>1,5 m 3 m 6 m</p>	<p>2 profils</p>
					<p><b>S</b></p> <p>0 110 32'</p> <p><b>WL</b></p> <p>0 110 34'</p> <p><b>BL</b></p> <p>0 110 35'</p>	<p>3 m</p>	<p>1 perfil 1 profile 1 profil</p>

'El perfil incluye junta + juegos de tapas laterales | 'This profile includes PVC joints + set of end caps | 'Le profil inclue jointes plastiques + capuchons finals

2 m - 2 juegos de tapas | 2 set of caps | 2 set de caupuchons finals 3 m - 4 juegos de tapas | 4 set of caps | 4 set de caupuchons finals 6 m - 6 juegos de tapas | 6 set of caps | 6 set de caupuchons finals

**S** Aluminio anodizado plata mate  
Satin anodized aluminium  
Aluminium anodisé argent





**WL** Aluminio lacado blanco mate  
Matt white lacquered aluminium  
Aluminium anodisé laqué blanc mat

**BL** Aluminio lacado negro mate  
Matt black lacquered aluminium  
Aluminium anodisé laqué noir mat

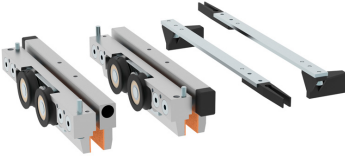

Componentes

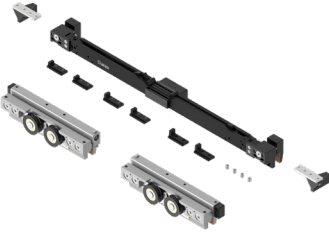
Components | Composants

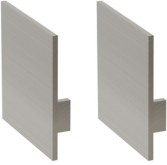
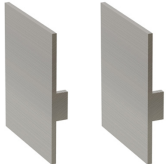
JUEGOS   SETS   JEUX		Acabado	Cód.		
	<p>Juego accesorios <b>SV-X110</b> x2 Freno retenedor SV-X110 Fitting set. x2 Retaining brake Garniture SV-X110. x2 Frein de retenue</p> <p>110kg por hoja   per panel   par panneaux</p> 		0 109 00		1 juego 1 set 1 jeu
	<p>Juego accesorios <b>SV-X110</b>. x1 SofTop doble SV-X110 Fitting set with x1 double SofTop Garniture SV-X110 avec x1 SofTop double</p> <p>110kg por hoja   per panel   par panneaux</p>   <p><b>SOFTOP</b> MAX. 110Kg</p>		0 108 00		1 juego 1 set 1 jeu
ACCESORIOS   ACCESSORIES   ACCESSOIRES		Acabado	Cód.		
	<p>Juego de tapas laterales para perfil superior. Montaje a techo o pared Lateral cap set for top track. Ceiling and wall mounting Jeu de capuchons latéraux pour rail supérieur. Fixation à mur et à plafond</p>	<p><b>PPS</b></p> <p><b>PPW</b></p> <p><b>PPB</b></p>	0 109 90 0 119 93 0 119 95		1 juego 1 set 1 jeu
	<p>Juego de tapas laterales para perfil superior para vidrio fijo. Montaje a techo o pared Lateral cap set for top track for fixed glass. Ceiling or wall mounting Jeu de capuchons latéraux pour rail supérieur pour verre fixe. Fixation à mur et à plafond</p>	<p><b>PPS</b></p> <p><b>PPW</b></p> <p><b>PPB</b></p>	0 109 92 0 119 94 0 119 96		1 juego 1 set 1 jeu

PPS

Plástico pintado plata  
Plastic painted silver  
PVC finition peinture argent

PPW

Plástico pintado blanco  
Plastic painted white  
PVC finition peinture blanche

PPB

Plástico pintado negro  
Black painted plastic  
PVC peinture noir



## Componentes

Components | Composants



ACCESORIOS   ACCESSORIES   ACCESSOIRES		Acabado	Cód.	
	<p>Juego de tapas laterales para perfil superior <b>para accesorio Frame</b>. Montaje a techo. Lateral cap set for top track for accessory Frame. Ceiling mounting. Jeu de capuchons latéraux pour rail supérieur pour accessoire Frame. Fixation à plafond.</p>	<p><b>S</b></p> <p><b>WL</b></p> <p><b>BL</b></p>	<p>00 70 78</p> <p>00 70 77</p> <p>00 70 79</p>	<p>1 juego</p> <p>1 set</p> <p>1 jeu</p>
	<p>Soporte para pared de vidrio Glass wall support Support mur pour installation sur verre</p>		00 70 84 <sup>1</sup>	<p>10 piezas</p> <p>10 pieces</p> <p>10 pièces</p>
	<p>Guiador inferior para vidrio de 8-14 mm Bottom guide for glass of 8-14mm Guide inférieur pour verre de 8-14mm</p>	<p><b>S</b></p> <p><b>WL</b></p> <p><b>BL</b></p>	<p>0 155 73</p> <p>00 71 90</p> <p>00 71 80</p>	<p>1 pieza</p> <p>1 piece</p> <p>1 pièce</p>
	<p>Junta transparente PVC PVC profile gasket Joint d'adaptation PVC</p> <p> 2x8mm</p> <p> 3x11mm</p> <p> 4x11mm</p>	<p><b>PVCT</b></p> <p><b>PVCB</b></p>	<p>00 45 82 (2mm)</p> <p>00 45 87 (3mm)</p> <p>00 45 84 (4mm)</p> <p>00 45 83 (2mm)</p> <p>00 45 90 (3mm)</p> <p>00 45 85 (4mm)</p>	<p>1 pieza</p> <p>1 piece</p> <p>1 pièce</p>
	<p>Tornillería sujeción 1 metro de perfil Bolts for securing 1 metre of track Vis de fixation 1 mètre de profil</p>		0 160 73	<p>1 juego</p> <p>1 set</p> <p>1 jeu</p>

<sup>1</sup>Para las familias que incorporen soporte pared con perfilería de 2 m, 3 m, 4 m o 6 m, aplicar cada 400mm | <sup>1</sup>For sets that incorporate a wall support with 2 m, 3 m, 4 m or 6 m profiling, apply every 400 mm | <sup>1</sup>Pour les familles intégrant un support mural avec huisserie de 2 m, 3m, 4 m ou 6 m, appliquer tous les 400 mm. 2 m - 6 soportes pared | supports wall | supports muraux 3 m - 8 soportes pared | supports wall | supports muraux 4 m - 10 soportes pared | supports wall | supports muraux 6 m - 15 soportes pared | supports wall | supports muraux



Componentes













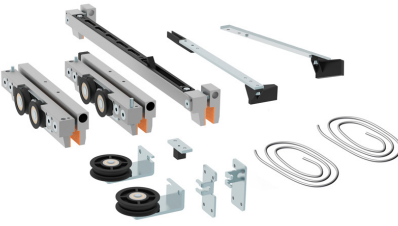







Components | Composants

KITS   KITS   KITS	Acabado	Cód.	المساحة	📦
 <p>Kit <b>SV-X110</b> x2 Freno retenedor SV-X110 Kit x2 Retaining brake Kit SV-X110 x2 Frein de retenue</p> <p>110kg por hoja   per panel   par panneaux</p>   <p>59x60mm</p>	<p>S</p>	<p>0 910 02 0 910 04</p>	<p>2 m 3 m</p>	<p>1 kit 1 jeu</p>
 <p>Kit <b>SV-X110</b>. x1 SofTop doble SV-X110 Kit x1 double SofTop Kit SV-X110 avec x1 SofTop double</p> <p>110kg por hoja   per panel   par panneaux</p>    <p>59x60mm</p> <p><b>SOFTOP</b> MAX. 110Kg</p>	<p>S</p>	<p>0 910 76 0 910 77</p>	<p>2 m 3 m</p>	<p>1 kit 1 jeu</p>
 <p>Kit <b>SV-X110</b> para vidrio fijo. x2 Freno retenedor SV-X110 Kit for fixed glass. x2 Retaining brake Kit SV-X110 pour verre fixe. x2 Frein de retenue</p> <p>110kg por hoja   per panel   par panneaux</p>   <p>59x70mm</p>	<p>S</p>	<p>0 910 14 0 910 16</p>	<p>2 m 3 m</p>	<p>1 kit 1 jeu</p>
 <p>Kit <b>SV-X110</b> para vidrio fijo. x1 SofTop doble SV-X110 Kit for fixed glass. x1 double SofTop Kit SV-X110 pour verre fixe. x1 SofTop double</p> <p>110kg por hoja   per panel   par panneaux</p>    <p>59x70mm</p> <p><b>SOFTOP</b> MAX. 110Kg</p>	<p>S</p>	<p>0 910 78 0 910 79</p>	<p>2 m 3 m</p>	<p>1 kit 1 jeu</p>

**Componentes**

Components | Composants

SV-X110 + **SELF CLOSE**

JUEGOS   SETS   JEUX		Acabado	Cód.		
	<p>Juego de accesorios SV-Selfclose X110                      x1 <b>SOFTPRO</b> + x1 Freno retenedor                      SV-Selfclose X110 Fitting set                      x1 <b>SOFTPRO</b> + x1 Retaining brake                      Garniture SV-Selfclose X110                      x1 <b>SOFTPRO</b> + x1 Frein de retenue</p> <p><b>110kg</b> por hoja   per panel   par panneaux</p>  		0 109 10		1 juego 1 set 1 jeu
	<p>Juego de accesorios SV-Selfclose X110  <b>SOFTPRO</b> doble                      SV-Selfclose X110 Fitting set                      double <b>SOFTPRO</b>                      Garniture SV-Selfclose X110  <b>SOFTPRO</b> double</p> <p><b>110kg</b> por hoja   per panel   par panneaux</p>  		0 109 11		1 juego 1 set 1 jeu
KITS   KITS   KITS		Acabado	Cód.		
	<p>Kit SV-Selfclose X110 x1 <b>SOFTPRO</b>                      + x1 Freno retenedor                      Kit SV-Selfclose X110 x1 <b>SOFTPRO</b>                      + x1 Retaining brake                      Kit SV-Selfclose X110 x1 <b>SOFTPRO</b>                      + x1 Frein de retenue</p> <p><b>110kg</b> por hoja   per panel   par panneaux</p>    <p>59x60mm</p>		0 910 80 0 910 81	2 m 3 m	1 kit 1 jeu
	<p>Kit SV-Selfclose X110 para vidrio fijo                      x1 <b>SOFTPRO</b> + x1 Freno retenedor                      Kit SV-Selfclose X110 for fixed glass                      x1 <b>SOFTPRO</b> + x1 Retaining brake                      Kit SV-Selfclose X110 pour verre fixe                      x1 <b>SOFTPRO</b> + x1 Frein de retenue</p> <p><b>110kg</b> por hoja   per panel   par panneaux</p>    <p>59x70mm</p>		0 910 88 0 910 89	2 m 3 m	1 kit 1 jeu



# Compact Glass

SV-X150

# COMPACT GLASS

BIBLIOTECA  
DE DESCARGAS



DOWNLOADS LIBRARY |  
BIBLIOTHÈQUE  
TÉLÉCHARGEMENTS

## ES

SV-X150 es una solución de deslizamiento compacta ya que oculta todos sus mecanismos en la guía y reduce al mínimo el espacio entre la hoja y la pared. Fácil de instalar, práctica, inmediata y con un diseño muy atractivo. Además, está capacitada para soportar hojas de vidrio de gran envergadura (hojas de hasta 150kg de peso)

Este producto permite elegir entre distintos sistemas de frenado: Anti-shock, Freno retenedor y el novedoso sistema **SOFTPRO**, una solución única en el mercado para el frenado suave de puertas correderas. Con ésta innovación, Saheco garantiza un cerrado suave, seguro y silencioso, además de una mayor facilidad y funcionalidad en la instalación.

## EN

SV-X150 is a compact sliding solution since it conceals all its mechanisms in the guide and reduces the space between the panel and the wall to a minimum. It is easy to install, practical, immediate and with a very attractive design. In addition, it is designed to support large-sized panes of glass (panes of up to 150kg in weight)

There is a choice between different braking systems: anti-shock, retaining brake and our new **SOFTPRO** system, an exceptional solution for a smooth and quiet sliding action with an effective, powerful yet at the same time gentle soft closing and or opening action.

## FR

SV-X150 est une solution de glissement compacte, car elle masque tous ses mécanismes dans le rail et réduit au minimum l'espace entre battant et mur. Modèle à installation facile, pratique et immédiate, au design très attrayant. Peut en outre supporter des battants en verre de grande envergure (jusqu'à 150 kg).

Ce produit vous permet de choisir entre les différents systèmes de freinage: Anti-choc, le frein de retenue et le nouveau système **SOFTPRO**, une solution unique sur le marché pour les portes coulissantes de freinage doux. Grâce à cette innovation, le nouveau système SAHECO, assure une fermeture lisse, calme et sûr, plus facile et la fonctionnalité dans l'installation.





## Características técnicas

Technical characteristics | Caractéristiques techniques

### Perfilería Profiles | Profils

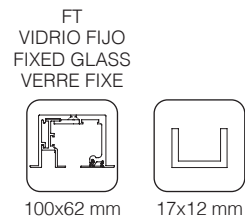
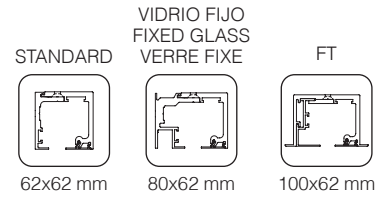

### Especificaciones Specifications | Spécification

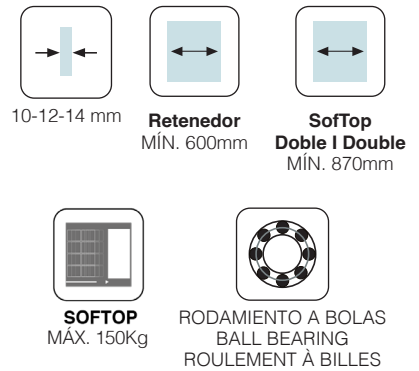

### Peso Weight | Poids

150 kg 331 lb

### Producto certificado

Certificated product | Produit certifié



**Variantes de instalación**

Installation possibilities | Variantes d'installation

**PARED**  
WALL  
MUR

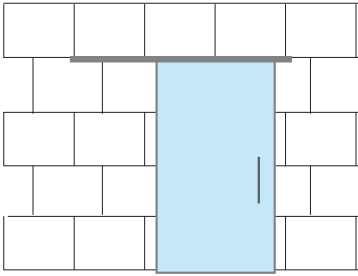

**PARED CON VIDRIO FIJO**  
WALL WITH FIXED PANEL  
MUR AVEC VERRE FIXE

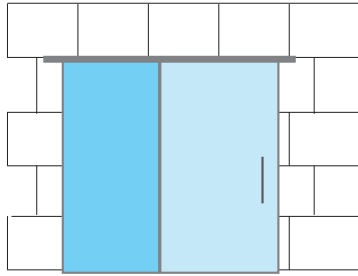

**TECHO**  
CEILING  
PLAFOND

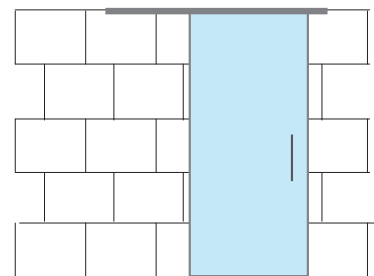

**TECHO CON VIDRIO FIJO**  
CEILING WITH FIXED PANEL  
PLAFOND AVEC VERRE FIXE

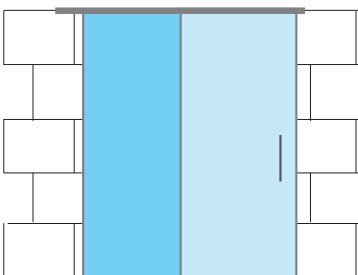

**FALSO TECHO**  
FALSE CEILING  
FAUX PLAFOND

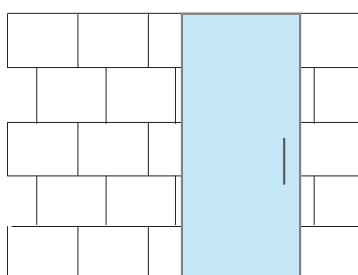

**FALSO TECHO CON VIDRIO FIJO**  
FALSE CEILING WITH FIXED PANEL  
FAUX PLAFOND AVEC VERRE FIXE

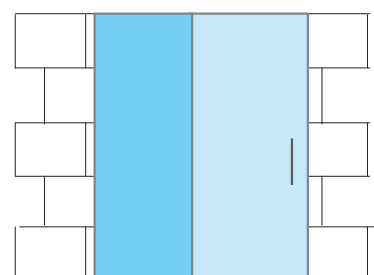

**PARED DE VIDRIO**  
GLASS WALL  
MUR DE VERRE

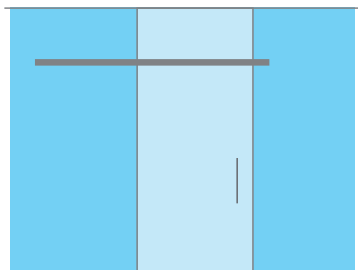

**TECHO CON VIDRIO FIJO**  
CEILING WITH FIXED PANEL  
PLAFOND AVEC VERRE FIXE

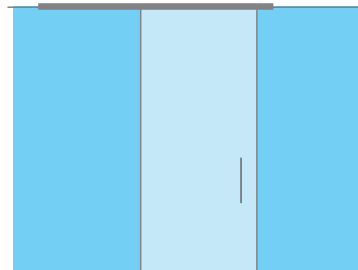

**FALSO TECHO CON VIDRIO FIJO**  
FALSE CEILING WITH FIXED PANEL  
FAUX PLAFOND AVEC VERRE FIXE

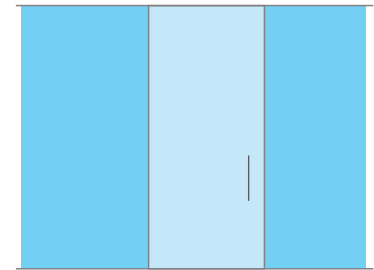

 **PUERTA CORREDERA** | SLIDING DOOR | PORTE COULISSANTE

 **VIDRIO FIJO** | FIXED GLASS | VERRE FIXE

**Sección tipo**

Cross-section | Section type (Cotas en mm | Dimensions in mm | Dimensions en mm)

**MONTAJE A PARED** | WALL MOUNTING | FIXATION À MUR

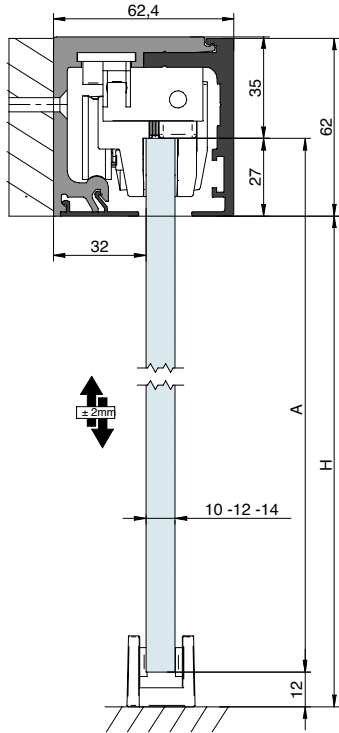

$A = H + 17$

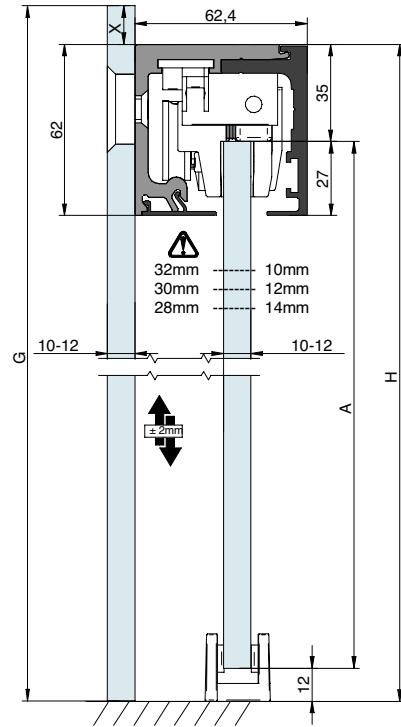

$A = H - 47$

$G = H + X$



Sección tipo

Cross-section | Section type (Cotas en mm | Dimensions in mm | Dimensions en mm)

MONTAJE A TECHO | CEILING MOUNTING | FIXATION À PLAFOND

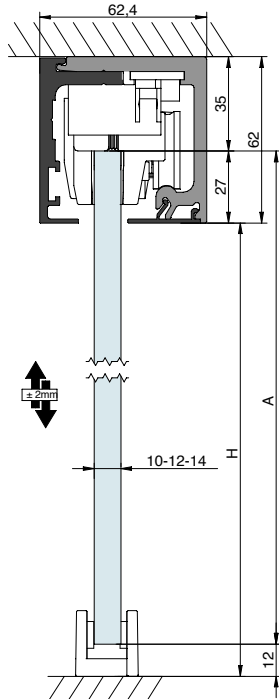

A = H + 15

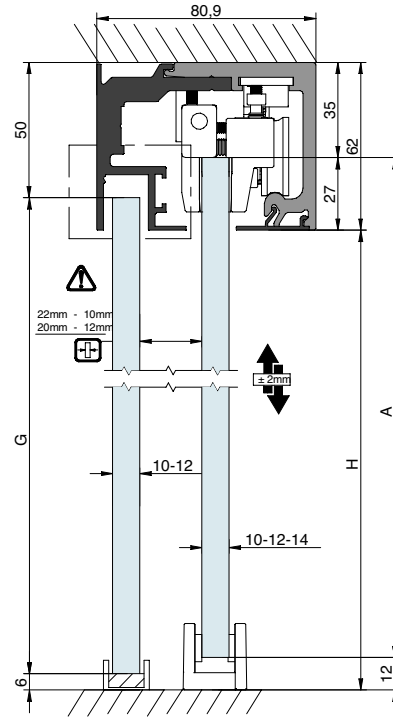

A = H + 15

G = H + 5

MONTAJE A FALSO TECHO | FALSE CEILING MOUNTING | FIXATION À FAUX-PLAFOND

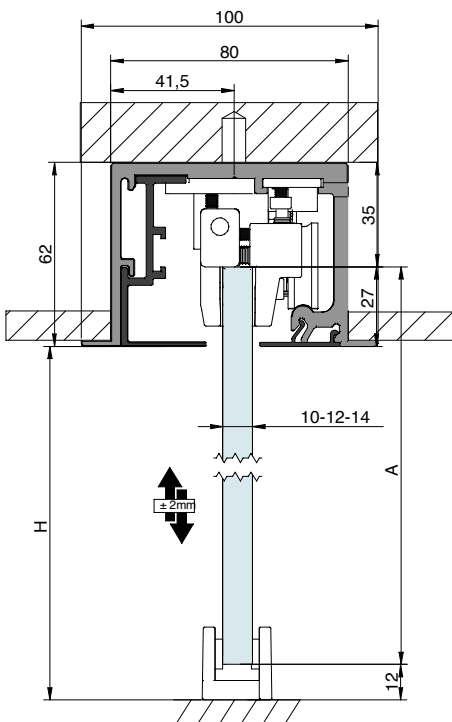

A = H + 15

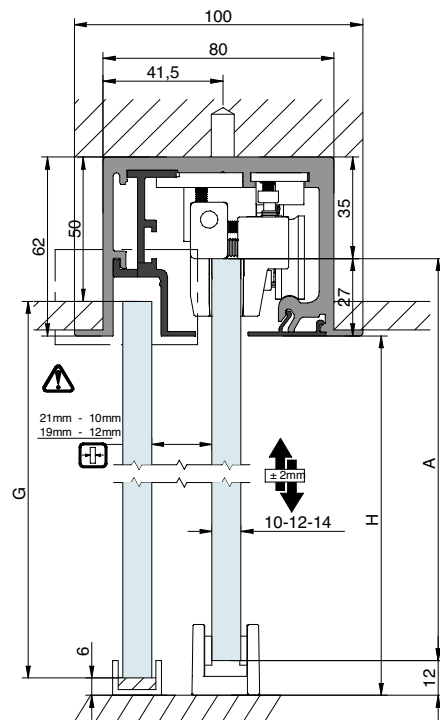











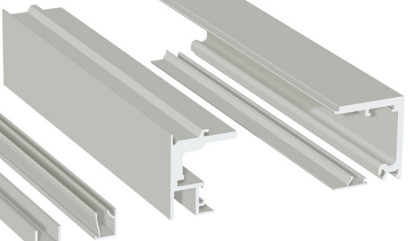

A = H + 15

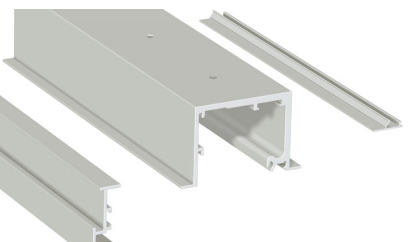
G = H + 5

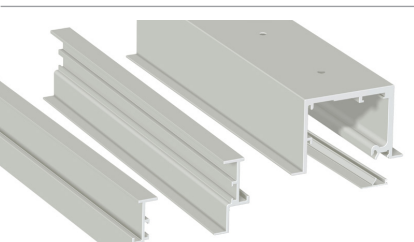

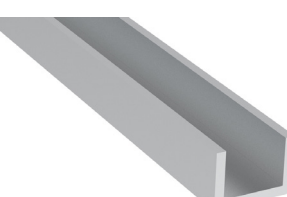
Componentes

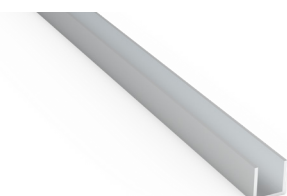
Components | Composants

PERFILERÍA   PROFILES   PROFILS		Acabado	Cód.		
 <p>Conjunto perfil superior corredero Sliding top track set Jeu rail supérieur coulissant</p>  <p>62x62mm</p>	S	0 157 20 0 157 30 0 157 40 0 157 60	2 m 3 m 4 m 6 m	1 juego 1 set 1 jeu	
 <p>Conjunto perfil superior corredero para vidrio fijo Sliding top track set for fixed glass Jeu rail supérieur coulissant pour verre fixe</p>  <p>80x62mm</p>	S	0 157 24 0 157 34 0 157 44 0 157 64	2 m 3 m 4 m 6 m	1 juego 1 set 1 jeu	
 <p>Conjunto perfil superior corredero <b>FT</b>. Montaje a falso techo FT sliding top track set. False ceiling mounting Set rail supérieur coulissant FT. Fixation à faux plafond</p>  <p>100x62mm</p>	S	0 157 28 0 157 38 0 157 48 0 157 68	2 m 3 m 4 m 6 m	1 juego 1 set 1 jeu	
 <p>Conjunto perfil superior corredero <b>FT</b> para vidrio fijo. Montaje a falso techo FT sliding top track set for fixed glass. False ceiling mounting Set rail supérieur coulissant FT pour verre fixe. Fixation à faux plafond</p>  <p>100x62mm</p>	S	0 157 50 0 157 51 0 157 52 0 157 53	2 m 3 m 4 m 6 m	1 juego 1 set 1 jeu	
 <p>Perfil inferior para vidrio fijo de 8-10-12mm Bottom track for fixed glass of 8-10-12mm Rail inférieur pour verre fixe de 8-10-12mm</p>  <p>17x12mm</p>	S WL BL	00 87 34 00 71 91 00 71 81	3 m	1 perfil 1 profile 1 profil	
 <p>Rail inférieur pour verre fixe 8-10-12mm</p>  <p>20x20 mm</p>	S WL BL	00 87 15 00 87 30 00 87 60 00 88 15 00 88 30 00 88 60 00 89 15 00 89 30 00 89 60	1,5 m 3 m 6 m 1,5 m 3 m 6 m 1,5 m 3 m 6 m	2 perfils	



**S** Aluminio anodizado plata mate  
Satin anodized aluminium  
Aluminium anodisé argent

**WL** Aluminio lacado blanco  
White lacquered aluminium  
Aluminium anodisé laqué blanc

**BL** Aluminio lacado negro mate  
Matt black lacquered aluminium  
Aluminium anodisé laqué noir mat

**Componentes**

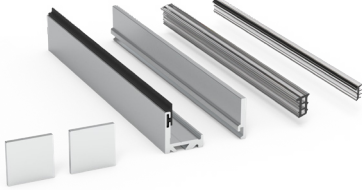

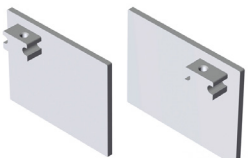



Components | Composants

PERFILERÍA   PROFILES   PROFILS		Acabado	Cód.		
 <p>Perfil inferior entrada frontal para vidrio fijo de 8-10-12 mm                      Bottom track front entry for fixed glass of 8-10-12mm                      Rail inférieur entrée frontale pour verre fixe de 8-10-12mm</p>  <p>21x20mm</p>	<p><b>S</b></p> <p><b>WL</b></p> <p><b>BL</b></p>	<p>0 110 32<sup>1</sup></p> <p>0 110 34<sup>1</sup></p> <p>0 110 35<sup>1</sup></p>	3 m		<p>1 perfil</p> <p>1 profile</p> <p>1 profil</p>
JUEGOS   SETS   JEUX		Acabado	Cód.		
 <p>Juego accesorios <b>SV-X150</b> x2 Freno retenedor                      SV-X150 Fitting set x2 Retaining brake                      Garniture SV-X150 x2 Frein de retenue</p> <p>150kg por hoja   per panel   par panneaux</p> 		0 155 05			<p>1 juego</p> <p>1 set</p> <p>1 jeu</p>
 <p>Juego accesorios <b>SV-X150</b>. x1 SofTop doble                      Fitting set SV-X150. x1 double SofTop                      Garniture SV-X150 x1 SofTop double</p> <p>150kg por hoja   per panel   par panneaux</p>   <p><b>SOFTOP</b> MAX. 150Kg</p>		0 156 00			<p>1 juego</p> <p>1 set</p> <p>1 jeu</p>
ACCESORIOS   ACCESSORIES   ACCESSOIRES		Acabado	Cód.		
 <p>Juego de tapas laterales para perfil superior.                      Montaje a techo o pared                      Lateral cap set for top track. Ceiling and wall mounting.                      Jeu de capuchons latéraux pour rail supérieur glissant. Fixation à mur et à plafond</p>	<p><b>PPS</b></p> <p><b>PPSS</b></p>	<p>0 155 74</p> <p>0 155 77</p>			<p>1 juego</p> <p>1 set</p> <p>1 jeu</p>
 <p>Juego de tapas laterales para perfil superior para vidrio fijo. Montaje a techo o pared                      Lateral cap set for top track for fixed glass. Ceiling or wall mounting                      Jeu de capuchons latéraux pour rail supérieur pour verre fixe. Fixation à mur et à plafond</p>	<p><b>PPS</b></p>	0 155 75			<p>1 juego</p> <p>1 set</p> <p>1 jeu</p>



Componentes

Components | Composants

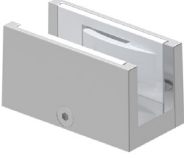
ACCESORIOS   ACCESSORIES   ACCESSOIRES	Acabado	Cód.	
 <p>Junta transparente PVC PVC profile gasket Joint d'adaptation PVC</p>    <p>2x8mm 3x11mm 4x11mm</p>	<p>PVCT</p> <p>PVCB</p>	<p>00 45 82 (2mm) 00 45 87 (3mm) 00 45 84 (4mm)  00 45 83 (2mm) 00 45 90 (3mm) 00 45 85 (4mm)</p>	<p>1 pieza 1 piece 1 pièce</p>
 <p>Soporte para pared de vidrio Glass wall support Support mur pour installation sur verre</p>		<p>00 70 84<sup>1</sup></p>	<p>10 piezas 10 pieces 10 pièces</p>
 <p>Tornillería sujeción 1 metro de perfil Bolts for securing 1 meter of track Vis de fixation 1 mètre de rail</p>		<p>0 155 76</p>	<p>1 juego 1 set 1 jeu</p>
 <p>Tornillería sujeción 1 metro de perfil Bolts for securing 1 meter of track Vis de fixation 1 mètre de rail</p>		<p>0 160 73</p>	<p>1 juego 1 set 1 jeu</p>
 <p>Guiador inferior para vidrio de 8-14 mm Bottom guide for glass of 8-14mm Guide inférieur pour verre 8-14mm</p>	<p>S</p>	<p>0 155 73</p>	<p>1 pieza 1 piece 1 pièce</p>

<sup>1</sup>Para las familias que incorporen soporte pared con perfilera de 2 m, 3 m, 4 m o 6 m, aplicar cada 400mm | <sup>1</sup>For sets that incorporate a wall support with 2 m, 3 m, 4 m or 6 m profiling, apply every 400 mm | <sup>1</sup>Pour les familles intégrant un support mural avec huisserie de 2 m, 3m, 4 m ou 6 m, appliquer tous les 400 mm. 2 m - 6 soportes pared | supports wall | supports muraux 3 m - 8 soportes pared | supports wall | supports muraux 4 m - 10 soportes pared | supports wall | supports muraux 6 m - 15 soportes pared | supports wall | supports muraux



**LEVIT GLASS**  
SV-LEVIT

# LEVIT GLASS

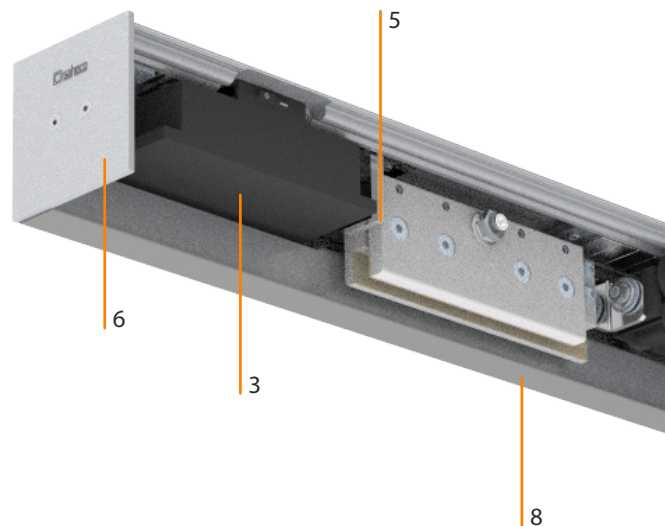

## — ES

**CON LEVIT ABRAZAMOS LAS TENDENCIAS Y OFRECEMOS UNA SOLUCIÓN PARA UNA VIDA MÁS SENCILLA, EFICIENTE Y CONECTADA.**

Levit ofrece una innovadora tecnología magnética de motor lineal que, integrada de forma compacta en una guía superior caracterizada por su excelente puesta en escena, nos permitirá abrir de forma automática puertas correderas de interior de hoteles, oficinas, centros sanitarios y/o cualquier ambiente arquitectónico.

**Apostamos fuerte por la innovación y perseguimos más que nunca nuestro “Late Motiv”: el confort de las personas.**

## — EN

**LEVIT EMBRACES TRENDS AND OFFERS A SOLUTION FOR A SIMPLER, MORE EFFICIENT, AND CONNECTED LIFE.**

Levit provides an innovative magnetic linear motor technology, seamlessly integrated into a top guide known for its excellent aesthetics, enabling automatic opening of interior sliding doors in hotels, offices, healthcare facilities, and/or any architectural environment.

**We are strongly committed to innovation and more than ever pursue our “Late Motiv”: the comfort of people.**

## — FR

**LEVIT EMBRASSE LES TENDANCES ET OFFRE UNE SOLUTION POUR UNE VIE PLUS SIMPLE, PLUS EFFICACE ET PLUS CONNECTÉE.**

Levit propose une technologie innovante de moteur linéaire magnétique, intégrée de manière compacte dans un rail supérieur réputé pour son excellente esthétique, permettant l'ouverture automatique de portes coulissantes intérieures dans les hôtels, les bureaux, les établissements de santé et/ou tout environnement architectural.

**Nous sommes fortement engagés dans l'innovation et poursuivons plus que jamais notre “Late Motiv” : le confort des personnes.**

### Producto con informe de laboratorio

Product with laboratory report |

Produit avec rapport de laboratoire

Durabilidad bajo normativa EN16005:

1.000.000 de ciclos |

Durability according to EN16005 standard:

1.000.000 cycles |

Durabilité selon la norme EN16005 : 1.000.000 de cycles



## Componentes principales perfil Levit

Componentes principales | Componentes principales

**1.** Perfil guía aluminio | Aluminium track | Rail en aluminium **2.** Motor lineal | Linear motor | Moteur linéaire **3.** Fuente de alimentación | Fuente de alimentación | Fuente de alimentación **4.** Imanes permanentes de neodimio | Imanes permanentes de neodimio | Imanes permanentes de neodimio **5.** Tope freno fin de carrera | Tope freno fin de carrera | Tope freno fin de carrera **6.** Tapa final perfil | Tapa final perfil | Tapa final perfil **7.** Tapa lateral perfil | Track lateral cap | Tapa lateral perfil **8.** Embellecedor vidrio fijo | Fixed glass trim | Capuchon verre fixe

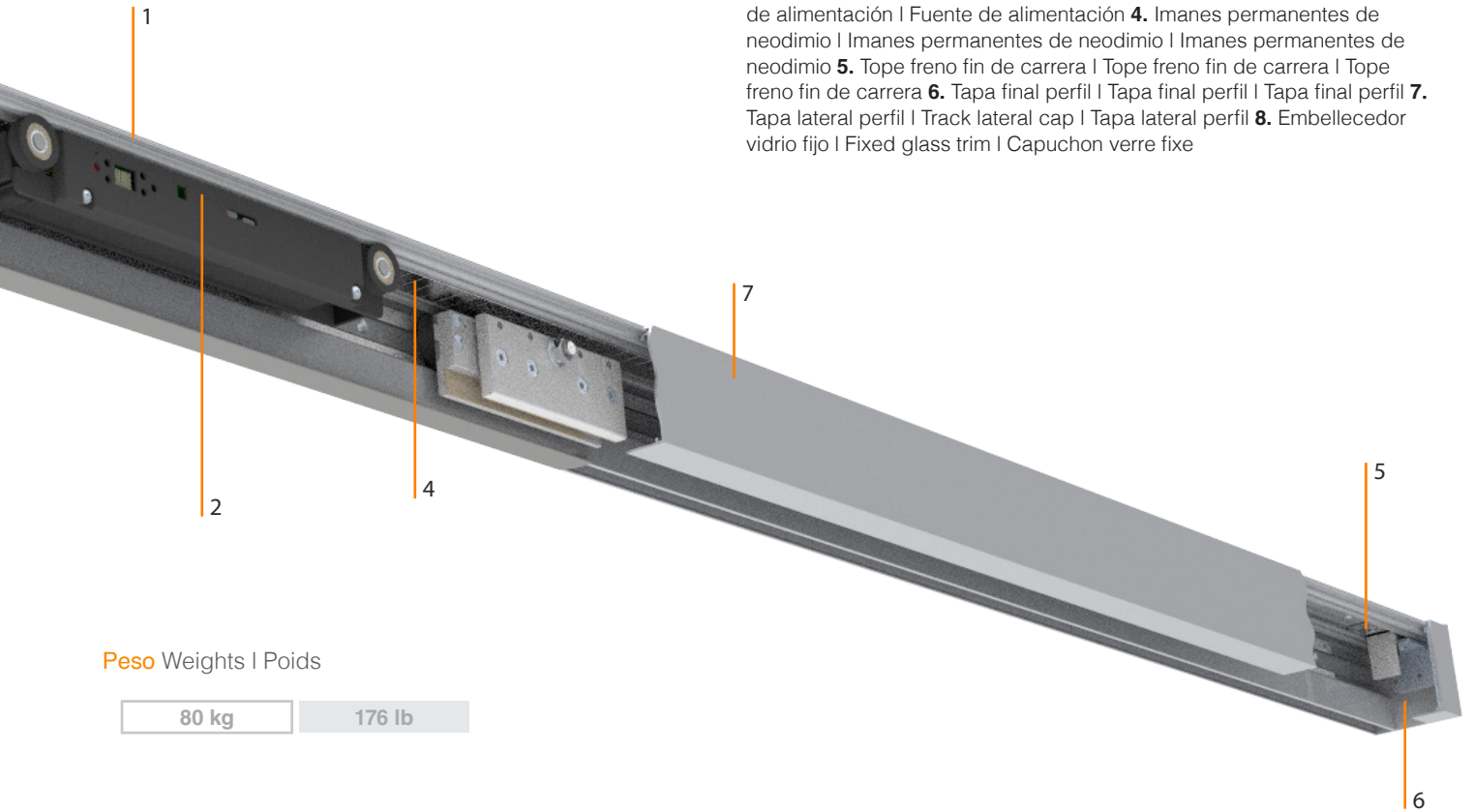

Peso Weights | Poids

80 kg

176 lb

## Componentes principales perfil Levit

Componentes principales | Componentes principales

### Descripción perfil Levit

Track description | Description rail

ES | Perfilera de aluminio compacta y elegante con alojamiento para vidrio fijo de únicamente 76x75mm y disponible en acabados aluminio anodizado plato mate y aluminio anodizado negro mate

EN | Compact and elegant aluminum profile with housing for fixed glass measuring only 76x75mm, available in matte anodized aluminum and matte black anodized aluminum finishes.

FR | Profilé en aluminium compact et élégant avec logement pour verre fixe mesurant seulement 76x75mm, disponible dans des finitions en aluminium anodisé mat et en aluminium anodisé

(Cotas en mm | Dimensions in mm | Dimensions en mm)

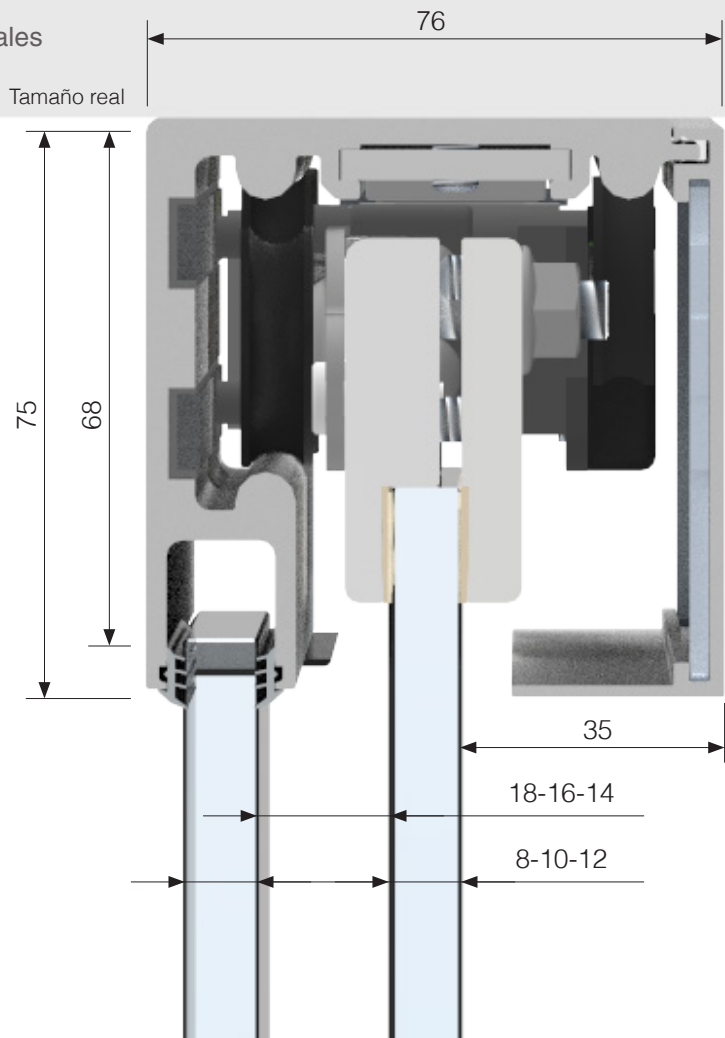

# LEVIT GLASS

## Características

Features | Caractéristiques



**PUSH & GO**



**INTERIOR DESIGN**



**SAFE & USE**

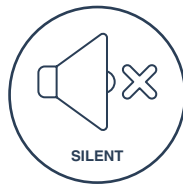

**SILENT**



**PLUG & PLAY**



**GREEN PRODUCT**



**COMPACT**



**EASY TO MAINTAIN**

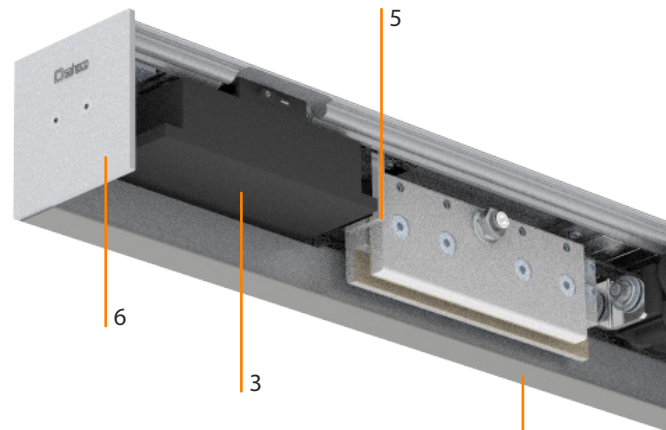

## Producto certificado

Certificated product | Produit certifié



## Componentes principales perfil Levit

Componentes principales | Componentes principales

**1.** Perfil guía aluminio | Aluminium track | Rail en aluminium **2.** Motor lineal | Linear motor | Moteur linéaire **3.** Fuente de alimentación | Fuente de alimentación | Fuente de alimentación **4.** Imanes permanentes de neodimio | Imanes permanentes de neodimio | Imanes permanentes de neodimio **5.** Tope freno fin de carrera | Tope freno fin de carrera | Tope freno fin de carrera **6.** Tapa final perfil | Tapa final perfil | Tapa final perfil **7.** Tapa lateral perfil | Track lateral cap | Tapa lateral perfil **8.** Embellecedor vidrio fijo | Fixed glass trim | Capuchon verre fixe

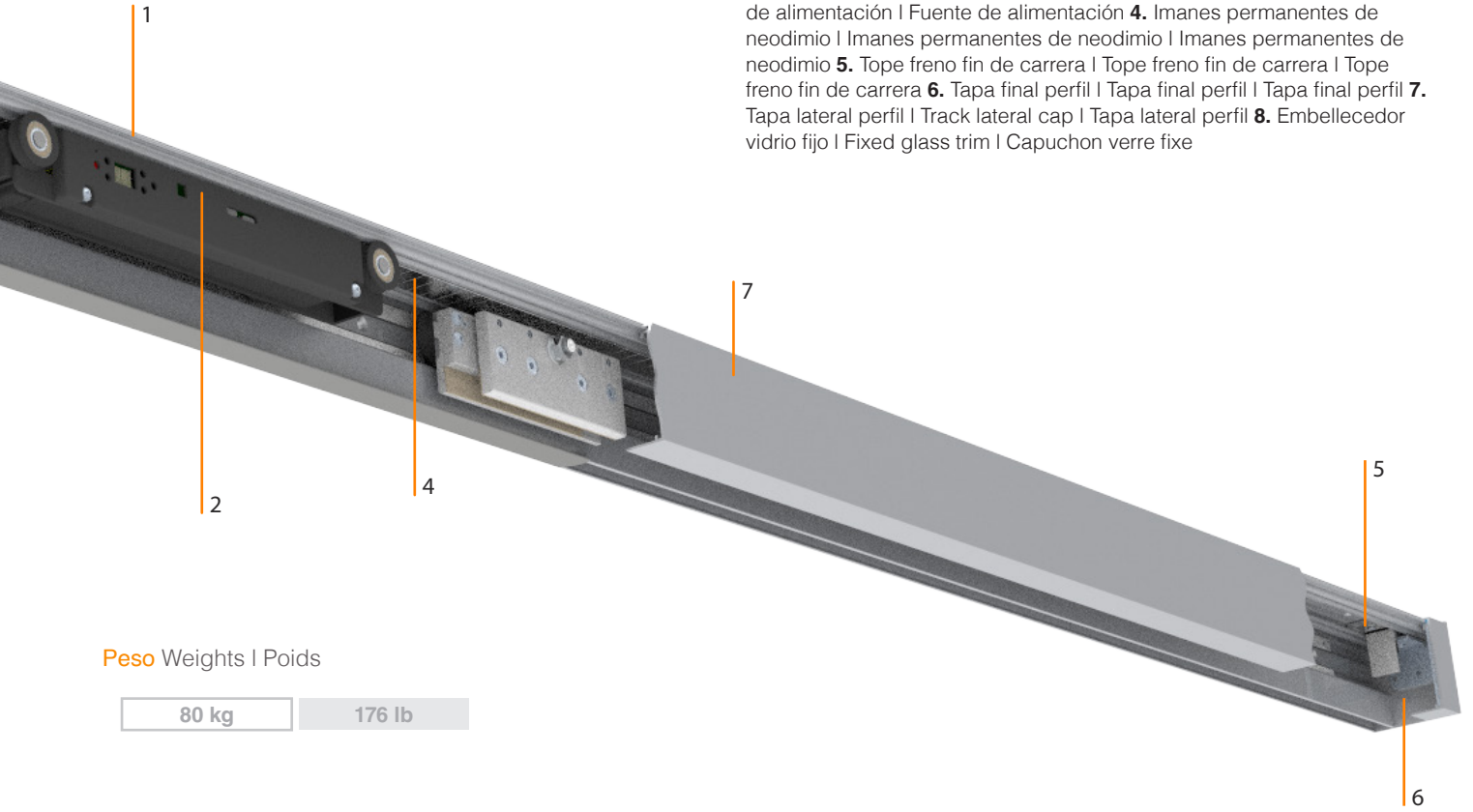

Peso Weights | Poids

80 kg

176 lb

## Descripción perfil Levit

Track description | Description rail

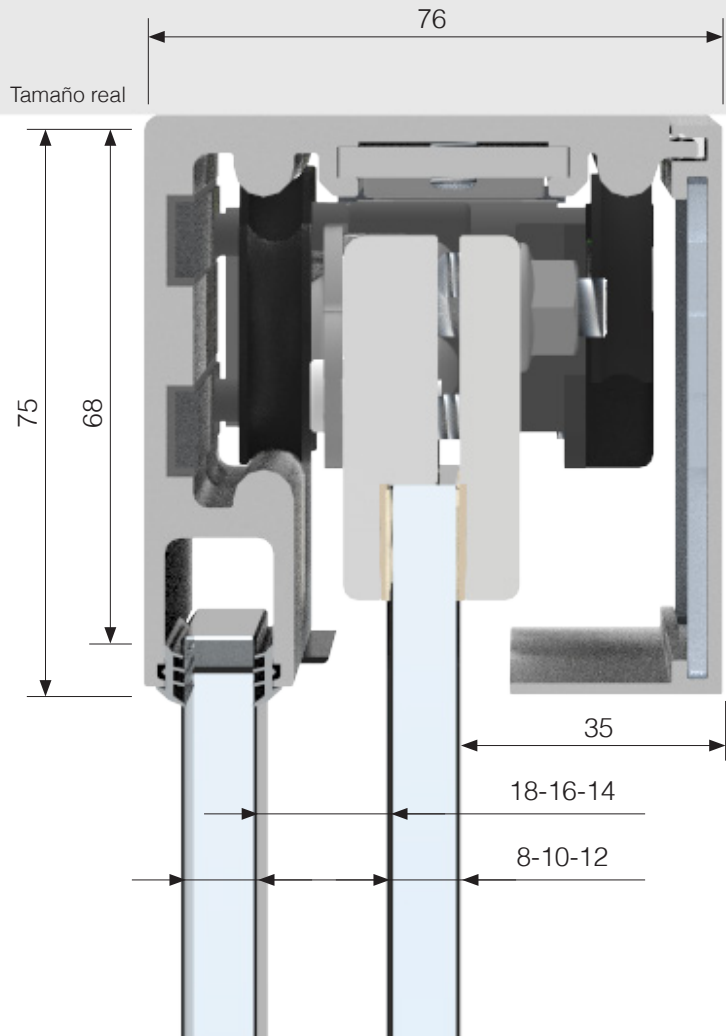

(Cotas en mm | Dimensions in mm | Dimensions en mm)



## Características

Features | Caractéristiques

# Pre-programmada\*, a medida y...

| Pre-programmed\*, customized and...| Pré-programmé\*, personnalisé et...

\* Tan sencillo como rellenar la "hoja de pedido" | As simple as filling out the attached "order form" |  
Aussi simple de remplir l'annexe "feuille de commande".



### PUSH & GO

La puerta se abre y cierra automáticamente tras un leve empuje. Opción de cierre automático después de 0s, 2.5s, 5s o 10s.

The door opens and closes automatically after a light push. Automatic closing option available after 0s, 2.5s, 5s, or 10s.

La porte s'ouvre et se ferme automatiquement après une légère poussée sur la feuille. Option de fermeture automatique disponible après 0s, 2.5s, 5s o 10s. 10s.





**SAFE & USE**

Responde al contacto con cualquier obstáculo y cumple con todas las normativas vigentes incluida la EN16005 (puertas peatonales motorizadas).

Responds to contact with any obstacle and complies with all current regulations including EN16005 (motorized pedestrian doors).

Responds to contact with any obstacle and complies with all current regulations including EN16005 (motorized pedestrian doors).



**PLUG & PLAY**

Conectar y listo. La instalación de Levit Glass no requiere de programación ni configuración adicional.

Levit Glass installation doesn't require any additional programming or configuration.

Brancher et prêt. L'installation de Levit Glass ne nécessite aucune programmation ni configuration supplémentaire



**COMPACT**

Estética elegante y discreta gracias al perfil compacto que oculta todo los mecanismos dentro de la guía.

Sleek and discreet aesthetics thanks to the compact profile that hides all mechanisms within the track.

Esthétique élégante et discrète grâce au profil compact qui dissimule tous les mécanismes à l'intérieur du rail



**EASY TO MAINTAIN**

Al prescindir de elementos mecánicos se minimiza el mantenimiento al nivel de una puerta corredera convencional.

By dispensing with mechanical elements, maintenance is minimized to the level of a conventional sliding door.

En supprimant les éléments mécaniques, la maintenance est minimisée au niveau d'une porte coulissante conventionnelle.



**INTERIOR DESIGN**

Diseñado para crear ambientes interiores, no apto para su instalación en exteriores.

Designed to create interior environments, not suitable for installation outdoors.

Conçu pour créer des ambiances intérieures, non adapté à une installation en extérieur

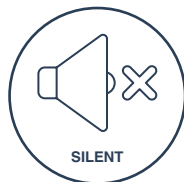

**SILENT**

Funcionamiento silencioso del motor con una emisión sonora por debajo de los 54dB.

Silent motor operation with a sound emission below 54dB.

Fonctionnement silencieux du moteur avec une émission sonore inférieure à 54 dB.



**GREEN PRODUCT**

Ecoamigabilidad acústica, contribuyendo así a un entorno más saludable y confortable.

Ensuring an acoustic eco-friendliness, contributing to a healthier and more comfortable environment.

En garantissant une éco-amicalité acoustique, contribuant ainsi à un environnement plus sain et confortable.



## Accesorios

Accessories | Accessoires

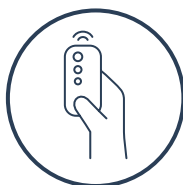

### 1 Control remoto Remote control | Télécommande

#### Dos operaciones a distancia:

- Automática (auto): en este modo, la puerta abre, queda en esta posición durante unos segundos (según se haya programado) para luego cerrar, cada vez que se activa el mando o el pulsador.
- Abierto (open): en este modo, la puerta se abrirá completamente y se mantendrá en esta posición hasta que se elija un nuevo modo de operación. Durante el modo "Abierto", la hoja puede moverse manualmente, lo que es útil para limpiarla, mientras que los controles de activación permanecerán inactivos.

#### Two remote operations:

- Auto: in this mode, the door opens, remains in this position for a few seconds (as programmed), and then closes every time the remote control or button is activated.
- Open: In this mode, the door will open fully and remain in this position until a new operation mode is selected. During the "Open" mode, the door leaf can be manually moved, which is useful for cleaning, while the activation controls remain inactive.

#### Deux opérations à distance:

- Automatique (auto): dans ce mode, la porte s'ouvre, reste dans cette position pendant quelques secondes (selon la programmation), puis se ferme à chaque activation de la télécommande ou du bouton.
- Ouvert (open) : Dans ce mode, la porte s'ouvrira entièrement et restera dans cette position jusqu'à ce qu'un nouveau mode d'opération soit sélectionné. Pendant le mode "Ouvert", la feuille de porte peut être déplacée manuellement, ce qui est utile pour le nettoyage, tandis que les contrôles d'activation restent inactifs.

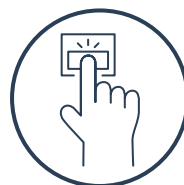

### 2 Pulsador inalámbrico Wireless push button | Bouton poussoir sans fil

La puerta se acciona tras pulsar el botón.

La puerta se acciona tras pulsar el botón.

La puerta se acciona tras pulsar el botón.





### Variantes de instalación

Installation possibilities | Variantes d'installation

**PARED**  
WALL  
MUR

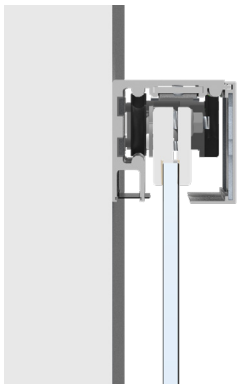

**TECHO**  
CEILING  
PLAFOND

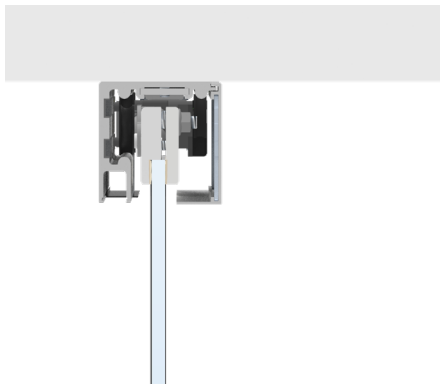

**TECHO CON VIDRIO FIJO**  
CEILING WITH FIXED PANEL  
PLAFOND AVEC VERRE FIXE





**Sección tipo**

Cross-section | Section type (Cotas en mm | Dimensions in mm | Dimensions en mm)

**MONTAJE A PARED | WALL MOUNTING | FIXATION À MUR**

80kg

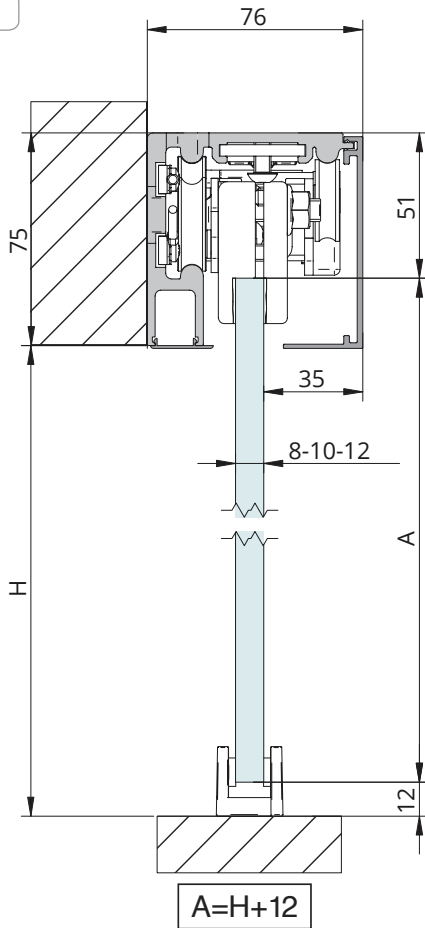

**MONTAJE A TECHO | CEILING MOUNT | FIXATION À TOIT**

80kg

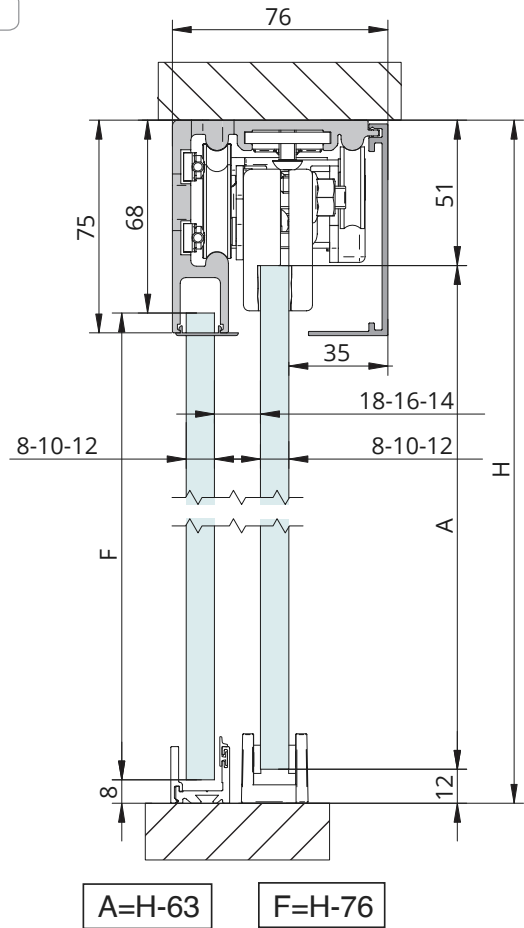



## Componentes

Components | Composants

### PERFILERÍA | PROFILES | PROFILS

Acabado

Cód.

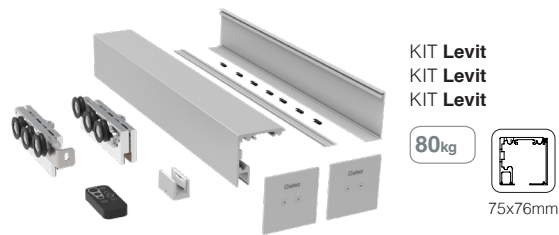

S

Izq.	Dcha.	
0 44 40	1700	1700 mm
0 44 40	1800	1800 mm
0 44 40	1900	1900 mm
0 44 40	2000	2000 mm
0 44 40	2100	2100 mm
0 44 40	2200	2200 mm
0 44 40	2300	2300 mm
0 44 40	2400	2400 mm
0 44 40	2500	2500 mm
0 44 40	2600	2600 mm
0 44 40	2700	2700 mm
0 44 40	2800	2800 mm
0 44 40	2900	2900 mm
0 44 40	3000	3000 mm

1 kit

BA

Izq.	Dcha.	
0 45 41	1700	1700 mm
0 45 41	1800	1800 mm
0 45 41	1900	1900 mm
0 45 41	2000	2000 mm
0 45 41	2100	2100 mm
0 45 41	2200	2200 mm
0 45 41	2300	2300 mm
0 45 41	2400	2400 mm
0 45 41	2500	2500 mm
0 45 41	2600	2600 mm
0 45 41	2700	2700 mm
0 45 41	2800	2800 mm
0 45 41	2900	2900 mm
0 45 41	3000	3000 mm

1 kit



S

0 110 22'	2 m
0 110 32'	3 m
0 110 62'	6 m

WL

0 110 24'	2 m
0 110 34'	3 m
0 110 64'	6 m

BL

0 110 25'	2 m
0 110 35'	3 m
0 110 55'	6 m

1 perfil  
 1 profile  
 1 profil

S Aluminio anodizado plata mate  
 Satin anodized aluminium  
 Aluminium anodisé argent

BA Aluminio anodizado negro  
 Black anodized aluminium  
 Aluminium anodisé noir

**Componentes**

Components | Composants

ACCESORIOS   ACCESSORIES   ACCESSOIRES		Acabado	Cód.	اساسيات	
	Pulsador inalámbrico <b>Levit</b> Wireless button <b>Levit</b> Bouton sans fil <b>Levit</b>		0 40 0001		1 pieza 1 piece 1 pièce
	Mando a distancia <b>Levit</b> Remote controle <b>Levit</b> Télécommande <b>Levit</b> 1 unidad incluida en el kit   1 unit included in the kit   1 unité incluse dans le kit		0 40 0002		1 pieza 1 piece 1 pièce
	Guiador inferior para vidrio de 8-14mm Bottom guide for glass of 8-14mm Guide inférieur pour verre de 8-14mm	S WL BA	0 155 73 00 71 90 00 71 80		1 pieza 1 piece 1 pièce



## **Multiplo Glass**

**SV-SINCRO | SV-T-PROGRESIVA | SV- T-PROGRESIVA SINCRO**

# MULTIPLIO GLASS

BIBLIOTECA  
DE DESCARGAS



DOWNLOADS LIBRARY |  
BIBLIOTHÈQUE  
TÉLÉCHARGEMENTS

## ES

Sistemas de puertas correderas de cristal suspendidas, sin marco y de alta calidad. Ideal para divisiones de uso doméstico o comercial de peso medio.

**1.**Innovación, desarrollo y gran estética, un sistema que permite operar con una apertura simultánea de todas las hojas, recogiendo a izquierda y a derecha de la instalación. **2.**Una perfecta integración de los espacios, con un máximo de 5 metros de hueco y 80 Kg por hoja; además de contar con un guiador inferior que destaca por su perfecta ocultación una vez las puertas están recogidas y, por lo tanto, dejando el paso completamente libre. **3.**También nos brinda la posibilidad de instalar vidrios fijos a ambos lados de la instalación, de modo que se pueden crear espacios con mucha más luz y profundidad. **4.**Del sistema anterior derivan la SINCRO y la SV-T PROGRESIVA. La primera para instalaciones de una hoja recogida a derecha y otra a izquierda y la segunda da solución a hojas recogidas a izquierda o derecha.

## EN

Systems of high quality, frameless, suspended glass sliding doors. Ideal for medium weight dividers and doors for home or commercial use.

**1.**Innovation, development and great aesthetics, a system that makes it possible to operate with a simultaneous opening of all the panels, parking them on the left and right of the installation. **2.**A seamless integration of areas, with a maximum of 5 meters of gap and 80 Kg per panel; with the special addition of having a bottom guide that is perfectly concealed once the doors are parked, thereby leaving the passage completely free. **3.**It also provides the possibility of installing fixed glass panes on both sides of the installation, in order to create areas with plenty of light and depth. **4.**From this previous system come the SINCRO and the SV-T PROGRESIVA. The first for installations with one panel parked to the right and another to the left, and the second providing a solution with panels parked either to the left or to the right.

## FR

Sont des systèmes de portes coulissantes en verre suspendues, sans encadrement et de qualité supérieure. Idéales pour les divisions et portes à usage résidentiel ou commercial de poids moyen.

**1.**Innovation, développement et ligne esthétique. Ce système permet d'assurer l'ouverture simultanée de tous les battants, en les regroupant à gauche et à droite de l'installation. **2.**Intégration parfaite des espaces, avec un maximum de 5 mètres d'ouverture et de 80 kg par battant. Elle est également munie d'un guide inférieur qui disparaît complètement une fois que les portes sont totalement ouvertes et laissent ainsi l'espace complètement libre. **3.**Cela permet en outre d'installer des vitres fixes de chaque côté de l'installation, de manière à créer des espaces dotés de beaucoup plus de lumière et de profondeur. **4.**Le modèle SINCRO et SV-T PROGRESIVA sont des variantes du système. Le premier est destiné à des installations d'un battant regroupé à droite et l'autre à gauche, tandis que le deuxième offre une solution de regroupement des battants à gauche ou à droite.





### Características técnicas

Technical characteristics | Caractéristiques techniques

### Perfilería Profiles | Profils



30x29 mm



33x33 mm

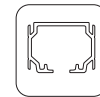

40x30 mm

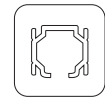

38x41 mm



17x12 mm



20x20 mm

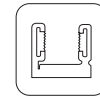

20x15 mm

### Especificaciones Specifications | Spécification

#### SINCRO 60/80

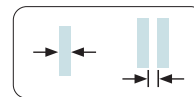

8 mm 19 mm  
10 mm 21 mm

#### T. PROG. SINCRO

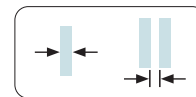

8 mm 30 mm  
10 mm 34 mm



RODAMIENTO A BOLAS  
BALL BEARING  
ROULEMENT À BILLES

### Peso Weight | Poids

90 kg	198 lb
125 kg	275 lb

### Producto certificado

Certificated product | Produit certifié



**Variantes de instalación**

Installation possibilities | Variantes d'installation

**TECHO**  
CEILING  
PLAFOND

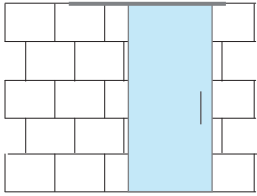

**TECHO CON VIDRIO FIJO**  
CEILING WITH FIXED GLASS  
PLAFOND AVEC VERRE FIXE

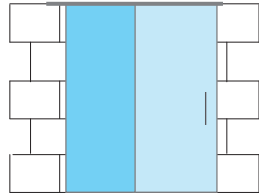

**FALSO TECHO**  
FALSE CEILING  
FAUX PLAFOND

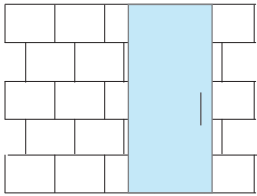

**FALSO TECHO CON VIDRIO FIJO**  
FALSE CEILING WITH FIXED GLASS  
FAUX PLAFOND AVEC VERRE FIXE

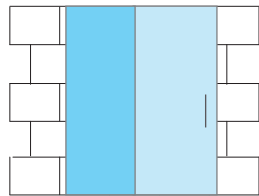

**Sección tipo**

Cross-section | Section type (Cotas en mm | Dimensions in mm | Dimensions en mm)

**MONTAJE A TECHO | CEILING MOUNTING | FIXATION À PLAFOND**

SV - SINCRO 60/80



STANDARD

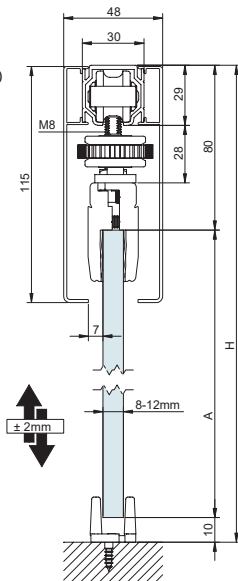

A= H-90



EXCELLENCE

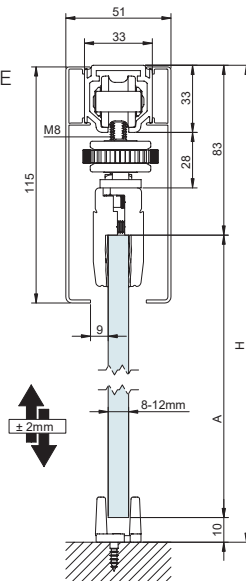

A= H-93

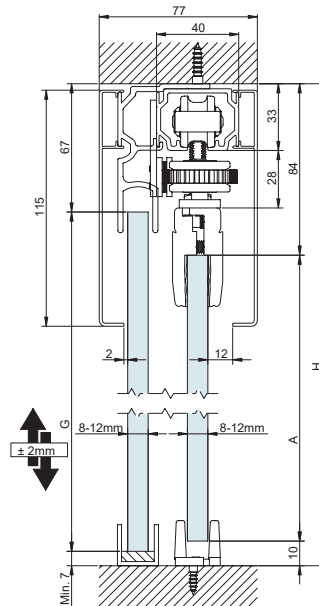

A= H-94

G= H-74

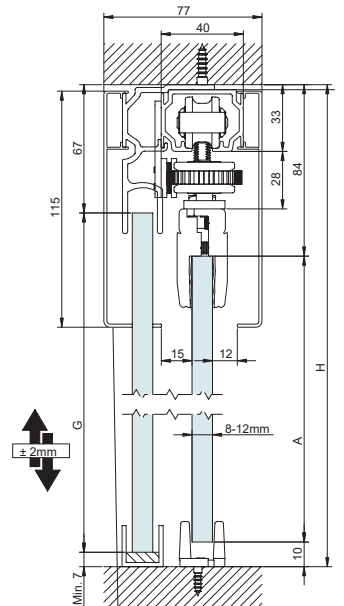

A= H-94

G= H-74



**Sección tipo**

Cross-section | Section type (Cotas en mm | Dimensions in mm | Dimensions en mm)

**MONTAJE A TECHO | CEILING MOUNTING | FIXATION À PLAFOND**

SV - SINCRO 100/125

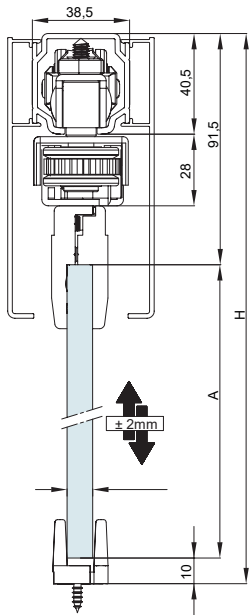

A= H-101,5

SV - T PROGRESIVA  
2 Hojas | 2 Panels | 2 Panneaux

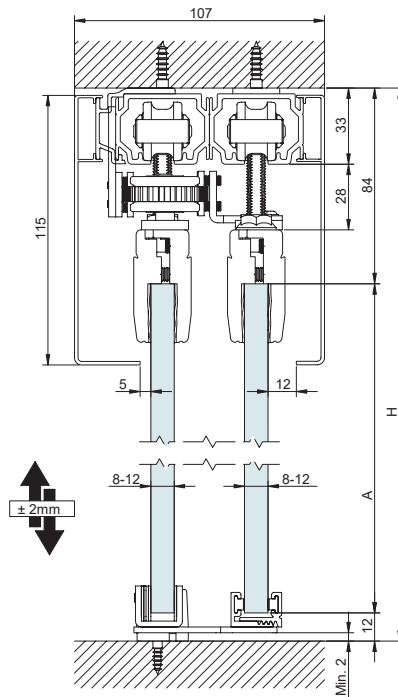

A= H-96

SV - T PROGRESIVA SINCRO  
2+2 Hojas | 2+2 Panels | 2+2 Panneaux

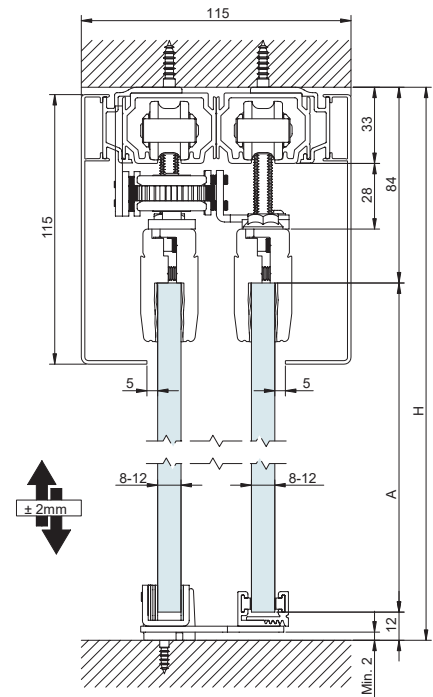

A= H-96

SV - T PROGRESIVA  
2 Hojas + vidrio fijo | 2 Panels + fixed glass | 2 Panneaux + verre fixe

SV - T PROGRESIVA SINCRO  
2+2 Hojas + vidrio fijo | 2+2 Panels fixed glass | 2+2 Panneaux + verre fixe

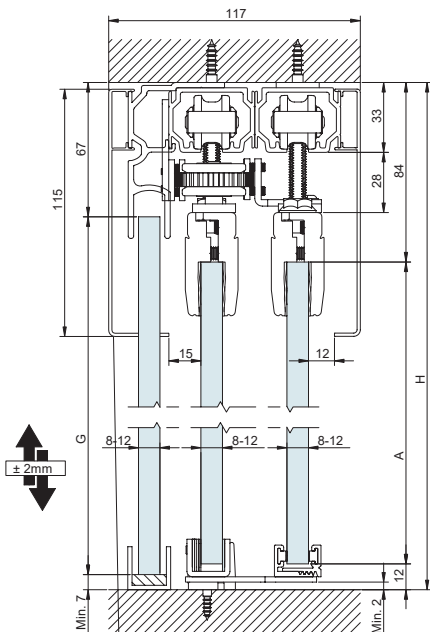

A= H-96  
A= H-74

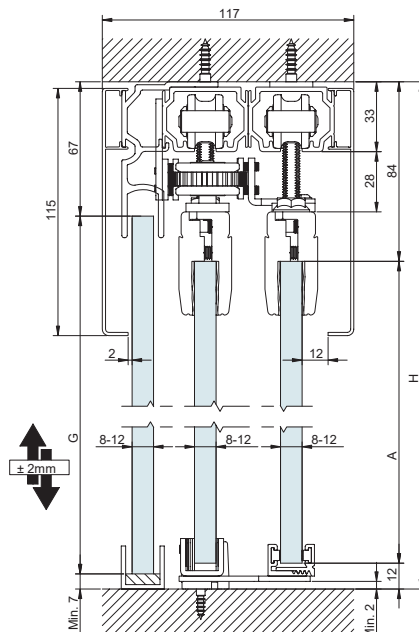

A= H-96  
A= H-74

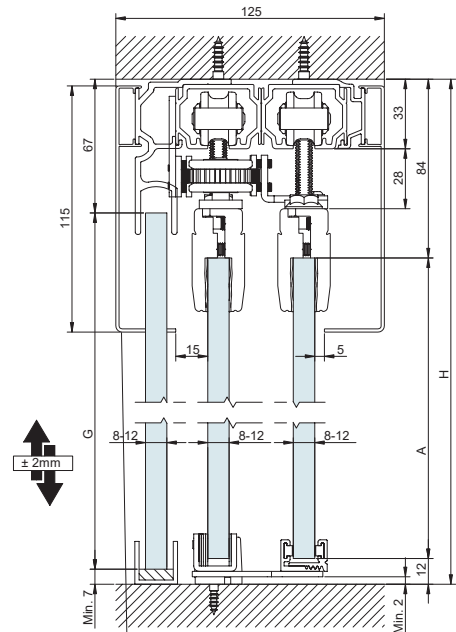

A= H-96  
A= H-74

**Sección tipo**

Cross-section | Section type (Cotas en mm | Dimensions in mm | Dimensions en mm)

**MONTAJE A FALSO TECHO** | FALSE CEILING MOUNTING | FIXATION À FAUX PLAFOND

**SV - T PROGRESIVA**  
 3 Hojas | 3 Panels | 3 Panneaux

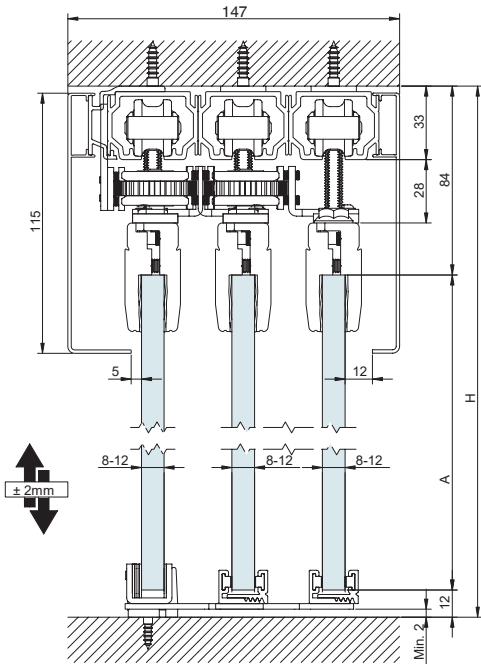

A= H-96

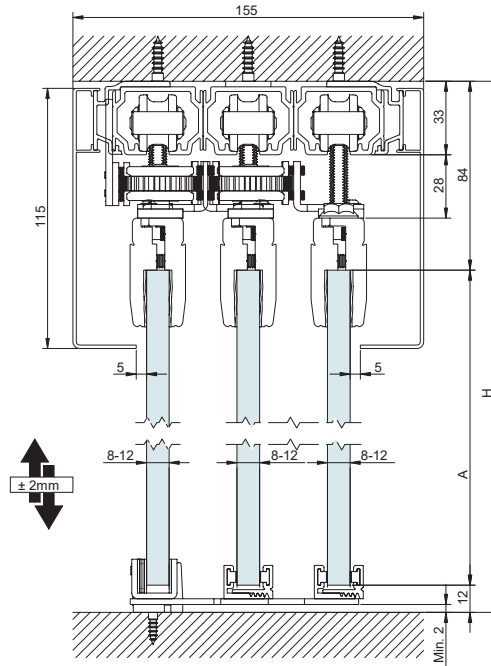

A= H-96

**SV - T PROGRESIVA**  
 3 Hojas + vidrio fijo | 3 Panels + fixed glass | 3 Panneaux + verre fixe

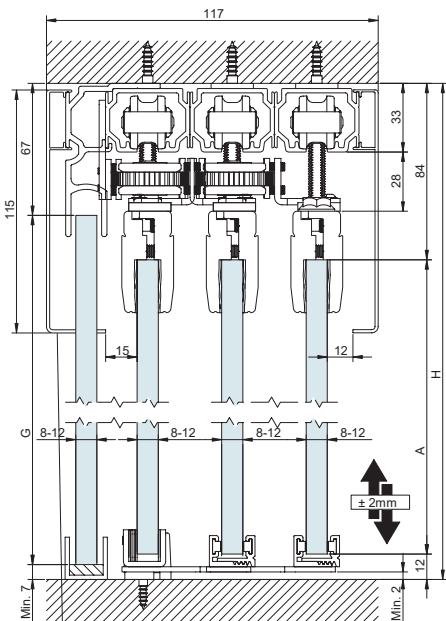

A=H-96

G=H-74

A= H-96

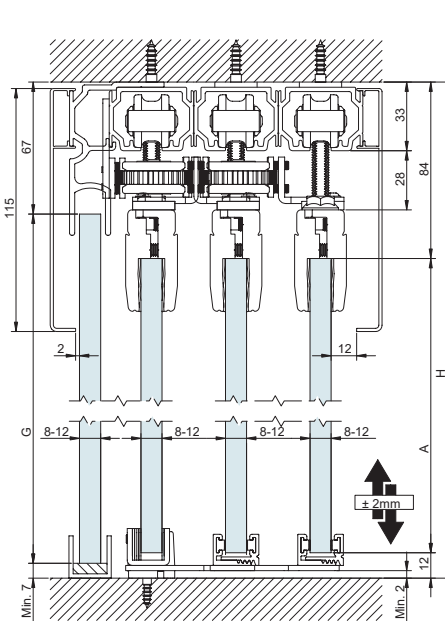

A=H-96

G=H-74

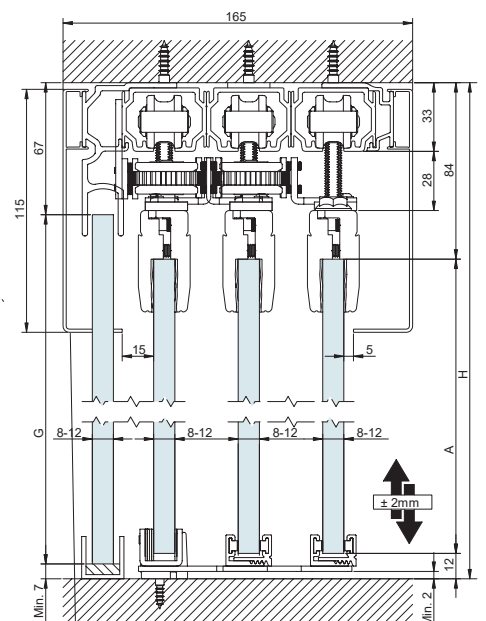

A=H-96

G=H-74













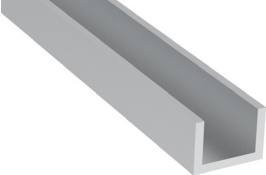



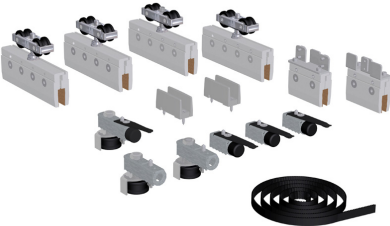

Componentes

Components | Composants

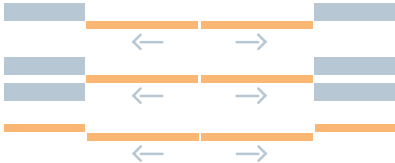
PERFILERÍA   PROFILES   PROFILS		Acabado	Cód.		
 <p>Perfil superior <b>Standard</b> Standard top track Rail supérieur Standard</p>  <p>30x29mm</p> <p><b>80kg</b></p>	<p>S</p> <p>MF</p>	<p>00 60 20</p> <p>00 60 30</p> <p>00 60 50</p>	<p>2 m</p> <p>3 m</p> <p>5 m</p>	<p>6 perfiles</p> <p>6 profiles</p> <p>6 profils</p>	
		<p>00 61 20</p> <p>00 61 30</p> <p>00 61 50</p>	<p>2 m</p> <p>3 m</p> <p>5 m</p>	<p>6 perfiles</p> <p>6 profiles</p> <p>6 profils</p>	
 <p>Perfil superior <b>Excellence</b>. Montaje a techo y pared Excellence top track. Wall and ceiling mounting Rail supérieur Excellence. Fixation à mur et à plafond</p>  <p>33x33mm</p> <p><b>90kg</b></p>	<p>S</p> <p>MF</p>	<p>0 105 20</p> <p>0 105 30</p> <p>0 105 50</p>	<p>2 m</p> <p>3 m</p> <p>5 m</p>	<p>2 perfiles</p> <p>2 profiles</p> <p>2 profils</p>	
		<p>0 105 21</p> <p>0 105 31</p> <p>0 105 51</p>	<p>2 m</p> <p>3 m</p> <p>5 m</p>		
 <p>Perfil superior Top track Rail supérieur</p>  <p>40x30mm</p> <p><b>90kg SV-T-PROG.</b></p>	<p>S</p>	<p>00 62 23</p> <p>00 62 33</p> <p>00 62 53</p>	<p>2 m</p> <p>3 m</p> <p>5 m</p>	<p>2 perfiles</p> <p>2 profiles</p> <p>2 profils</p>	
 <p>Soporte para vidrio fijo Fixing bracket for fixed glass Support pour verre fixe</p>	<p>S</p>	<p>00 63 01</p>	<p>0,10 m</p>	<p>2 piezas</p> <p>2 pieces</p> <p>2 pièces</p>	
 <p>Perfil superior <b>Standard XL</b> Standard XL top track Rail supérieur Standard XL</p>  <p>38x41mm No Softop</p> <p><b>125kg</b></p>	<p>S</p> <p>MF</p>	<p>0 126 20</p> <p>0 126 30</p> <p>0 126 50</p>	<p>2 m</p> <p>3 m</p> <p>5 m</p>	<p>1 perfil</p> <p>1 profile</p> <p>1 profil</p>	
		<p>0 126 21</p> <p>0 126 31</p> <p>0 126 51</p>	<p>2 m</p> <p>3 m</p> <p>5 m</p>	<p>1 perfil</p> <p>1 profile</p> <p>1 profil</p>	
 <p>Perfil inferior para vidrio fijo de 8-10-12mm Bottom track for fixed glass of 8-10-12mm Rail inférieur pour verre fixe de 8-10-12mm</p>  <p>20x20mm</p>	<p>S</p>	<p>00 87 15</p> <p>00 87 30</p> <p>00 87 60</p>	<p>1,5 m</p> <p>3 m</p> <p>6 m</p>	<p>2 perfiles</p> <p>2 profiles</p> <p>2 profils</p>	

**Componentes**

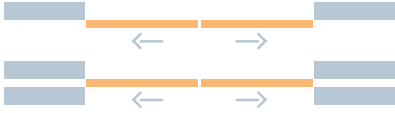







Components | Composants

PERFILERÍA   PROFILES   PROFILS		Acabado	Cód.		
	<p>Perfil inferior para vidrio fijo de 8-10-12mm                      Bottom track for fixed glass of 8-10-12mm                      Rail inférieur pour verre fixe de 8-10-12mm</p>  <p>17x12mm</p>		00 87 24	2 m	
			00 87 34	3 m	
	<p>Perfil inferior con burlete de 8-10-12mm                      Bottom track with brush of 8-10-12mm                      Rail inférieur avec bourrelet de 8-10-12mm</p>  <p>20x15mm</p>		00 84 24	2 m	
			00 84 34	3 m	
			00 84 64	6 m	
				00 71 96	
				00 71 91	3 m
				00 71 97	6 m
				00 71 86	2 m
				00 71 81	3 m
				00 71 87	6 m
JUEGOS   SETS   JEUX			Acabado	Cód.	
	<p>Juego de accesorios <b>SV-Sincro</b> para 2 puertas.                      Para montaje con vidrio fijo utilizar perfil                      00 62 23 - 00 62 33 - 00 62 53                      SV-Sincro fitting set for 2 doors. For fixed glass                      mounting use profile 00 62 23 - 00 62 33 -                      00 62 53                      Garniture SV-Sincro pour 2 portes. Pour                      installation avec verre fixe utiliser le rail 00 62 23                      - 00 62 33 - 00 62 53</p>  <p><b>90kg SV-SINCRO</b></p> <p>RODAMIENTO A BOLAS                      BALL BEARING                      ROULEMENT À BILLES</p> 		0 101 14		
					1 juego
	<p>Juego de accesorios <b>SV-Sincro 100/125kg</b> para                      2 puertas. Sistema no aplicable con vidrio fijo.                      SV-Sincro 100/125kg fitting set for 2 doors.                      System not applicable with fixed glass.                      Garniture SV-Sincro 100/125kg pour 2 portes.                      Système pas compatible avec verre fixe.</p>  <p><b>100-125kg SV-SINCRO</b></p> <p>RODAMIENTO A BOLAS                      BALL BEARING                      ROULEMENT À BILLES</p> 		0 101 15		
					1 juego

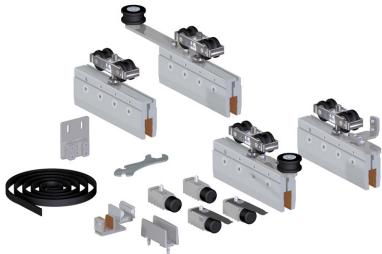

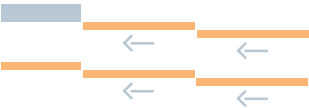

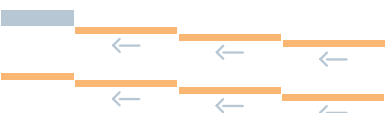

Componentes

Components | Composants

JUEGOS   SETS   JEUX	Acabado	Cód.		
 <p>Juego de accesorios <b>SV-T-PROG. SINCRO</b> para 4 puertas (2+2)                      SV-T-PROG. SINCRO Fitting set for 4 doors (2+2)                      Garniture SV-T-PROG. SINCRO pour 4 portes (2+2)</p> <div style="display: flex; align-items: center;">  <div style="margin-left: 10px;">  <p><b>90kg</b> SV-T-PROG.SINCRO</p> </div> </div> <p>40x30mm RODAMIENTO A BOLAS                      BALL BEARING                      ROULEMENT À BILLES</p> 		0 101 16		1 juego 1 set 1 jeu
 <p>Juego de accesorios <b>SV-T-PROG.</b> para 2 puertas. Sin mano                      SV-T-PROG. Fitting set for 2 doors. Without hand                      Garniture SV-T-PROG. pour 2 portes. Sans la main</p> <div style="display: flex; align-items: center;">  <div style="margin-left: 10px;"> <p><b>90kg</b> SV-T-PROG.</p> </div> </div> <p>RODAMIENTO A BOLAS                      BALL BEARING                      ROULEMENT À BILLES</p> 		0 101 17		1 juego 1 set 1 jeu
 <p>Juego de accesorios <b>SV-T-PROG.</b> para 3 puertas. Sin mano                      Fitting set SV-T-PROG. for 3 doors. Without hand                      Garniture pour 3 portes. Sans la main</p> <div style="display: flex; align-items: center;">  <div style="margin-left: 10px;">  <p><b>90kg</b> SV-T-PROG.</p> </div> </div> <p>40x30mm RODAMIENTO A BOLAS                      BALL BEARING                      ROULEMENT À BILLES</p> 		0 101 27		1 juego 1 set 1 jeu

## Componentes

Components | Composants

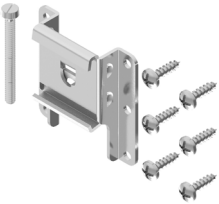
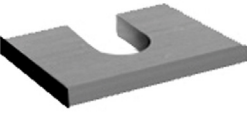
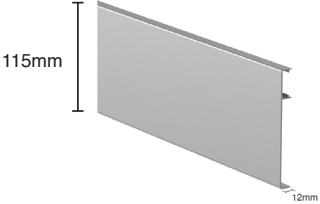
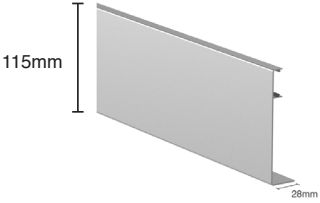
ACCESORIOS   ACCESSORIES   ACCESSOIRES			Acabado	Cód.		
	<p>Juego de roldanas <b>SV-A90</b>                      SV-A90 Roller set                      Jeu de galets SV-A90</p>  <p>RODAMIENTO A BOLAS                      BALL BEARING                      ROULEMENT À BILLES</p>  <p>90kg</p>			00 86 55		5 juegos 5 sets 5 jeux
	<p>Soporte separador tapeta                      Pelmet cover separator support                      Support séparateur cache</p>		<b>S</b>	00 63 04	0,10 m	1 pieza 1 pièce 1 pièce
	<p>Soporte tapeta universal                      Universal pelmet cover support                      Support cache universel</p>			00 66 59		10 piezas 10 pieces 10 pièces
	<p>Separador aluminio                      Aluminium separator                      Séparateur en aluminium</p>		<b>S</b>	00 60 61 <sup>1</sup>		25 piezas 25 pieces 25 pièces
 <p>115mm 12mm</p>	<p>Tapeta (Pestaña corta)                      Pelmet cover (Short flap)                      Cache (Languette court)</p>		<b>S</b>	00 66 21 00 66 31 00 66 51	2 m 3 m 5 m	2 perfiles 2 profiles 2 profils
 <p>115mm 28mm</p>	<p>Tapeta (Pestaña larga)                      Pelmet cover (Long flap)                      Cache (Languette large)</p>		<b>S</b>	00 66 23 00 66 33 00 66 53	2 m 3 m 5 m	2 perfiles 2 profiles 2 profils

<sup>1</sup>Para las familias que incorporen separador con periferia de 2 m, 3 m o 5 m, aplicar uno por cada taladro | <sup>1</sup>For sets that incorporate a separator with 2m, 3m, 5m or 6m profiling, apply one for each drill hole | <sup>1</sup>Pour les familles intégrant un séparateur avec profils de 2m, 3m, 5m ou 6m, appliquer un support pour chaque trou percé.

2 m - 10 separadores | separators | séparateurs 3 m - 15 separadores | separators | séparateurs 5 m - 25 separadores | separators | séparateurs



# Multiple Bloq Glass

SV-SINCRO Q110

# MULTIPLO BLOQ

g l a s s

El sistema **SV-Sincro Q110** permite abrir y cerrar paneles de vidrio de forma simultánea en dirección opuesta (derecha-izquierda) mediante un movimiento suave y coordinado. Esto significa, que al mover una puerta, la otra se desliza de forma sincronizada, creando una apertura o cierre más funcional y eficiente. Una solución ideal para aportar versatilidad a espacios con múltiples usos.

## Características principales:

- Sistema para **puertas correderas sincronizadas de vidrio**.
- **Perfil compacto** que oculta los mecanismos dentro de la guía, consiguiendo un aspecto estético inmejorable y permite instalación con **corredera y corredera más vidrio fijo (único perfil para juego de accesorios para SV-Q60 y SV-Q110)**.
- **Todos los ajustes son frontales**, haciendo de la instalación un proceso increíblemente fácil.
- Perfilería superior disponible en **aluminio natural**, aluminio **anodizado plata mate**, aluminio **lacado negro y blanco mate**.
- Posibilidad de **instalación a pared, a techo o falso techo**.
- **Rodamiento a bolas** para un deslizamiento silencioso y con mínimo esfuerzo.
- **Opciones de frenado:** freno retenedor (110Kg/hoja) y freno amortiguador SofTop bidireccional (55Kg/hoja) para un cierre y apertura de las puertas suave y sin impactos; además de prolongar la vida útil del producto.
- **Guiador inferior** para una instalación sin perfil inferior para un espacio de paso libre y sin obstáculos.
- Disponible en **formato Kit**.
- **Certificado Applus+** según normativa EN1527 de **200.000 ciclos de durabilidad** para sistemas con freno retenedor, duplicando, de este modo, los estándares fijados hasta el momento del producto Saheco.

BIBLIOTECA  
DE DESCARGAS



es más...

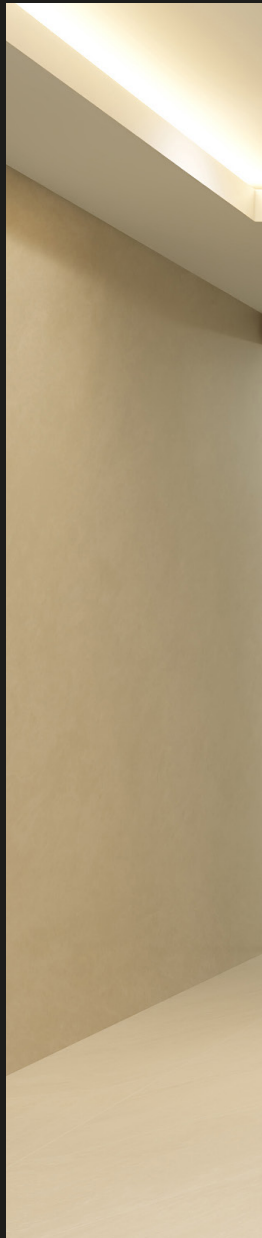



...  
**suavidad**  
**funcionalidad**  
**calidad**  
**diseño**  
**fácil instalación**

# Sincroniza tu acceso, transforma tu espacio.

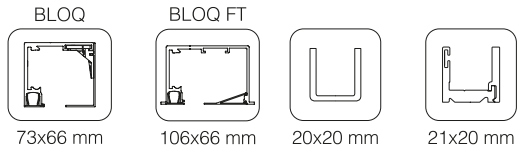

**Multiplo Bloq Glass** ofrece un solución de sincronizado que brinda un acceso a las estancias más amplio y fluido, optimizando el tránsito. El movimiento de una puerta acciona a la otra consiguiendo una misma proporción de apertura o cierre potenciado así la conexión entre espacios.

4

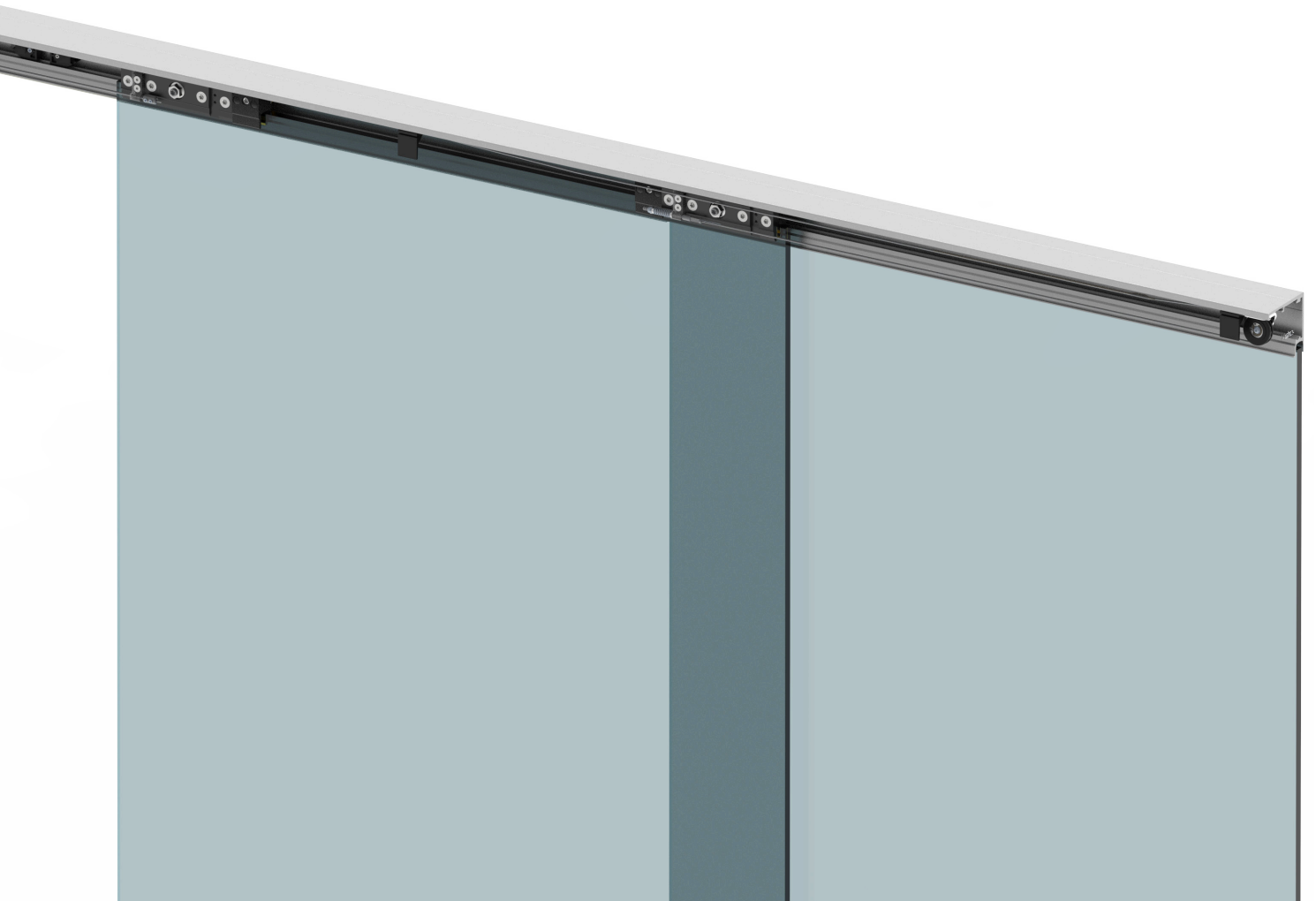
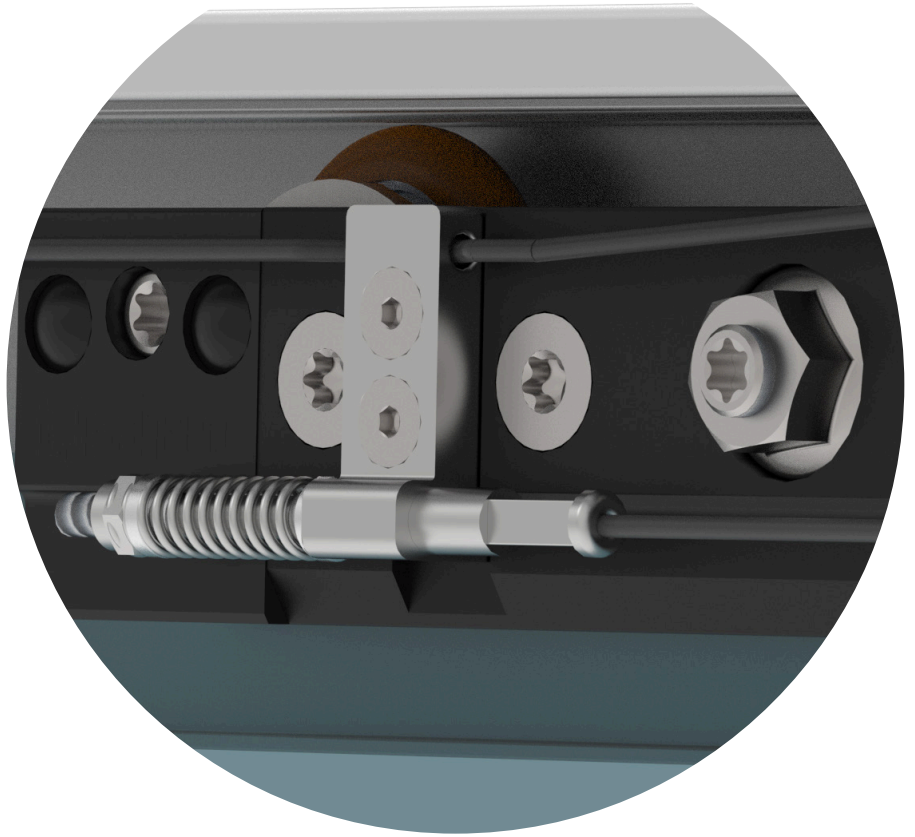

# Variantes de instalación

6

PARED

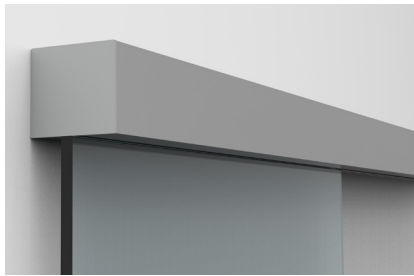
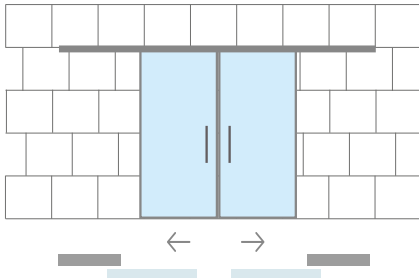

PARED CON VIDRIO FIJO

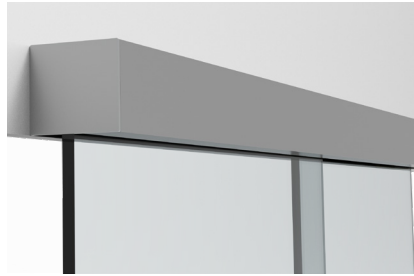
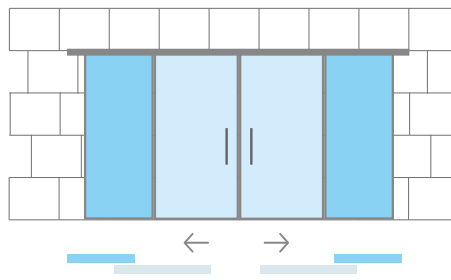

TECHO

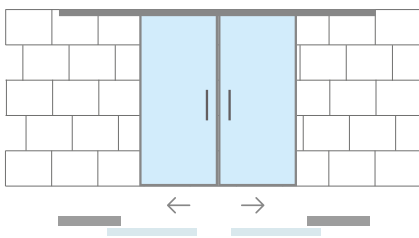

TECHO CON VIDRIO FIJO

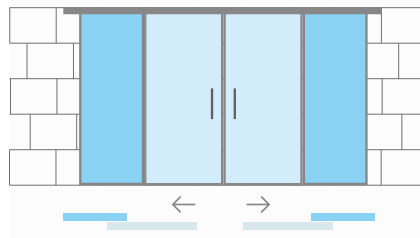

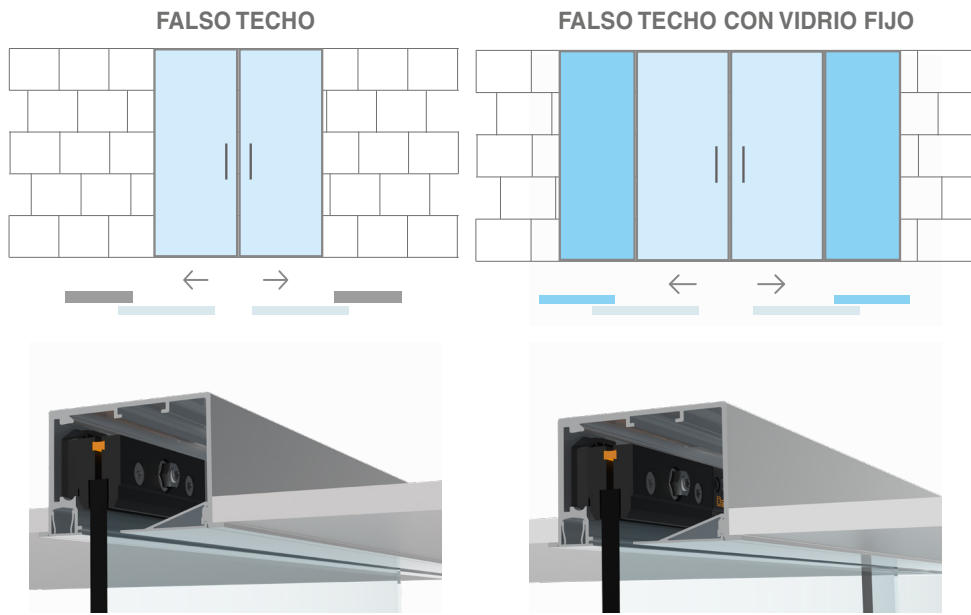

**TAPETA CUBE**

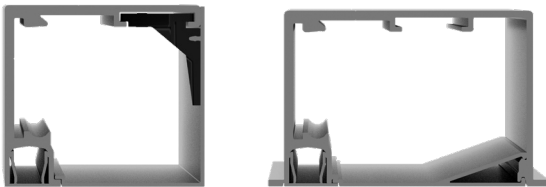

# Sección tipo

(Cotas en mm)

## /Montaje a pared

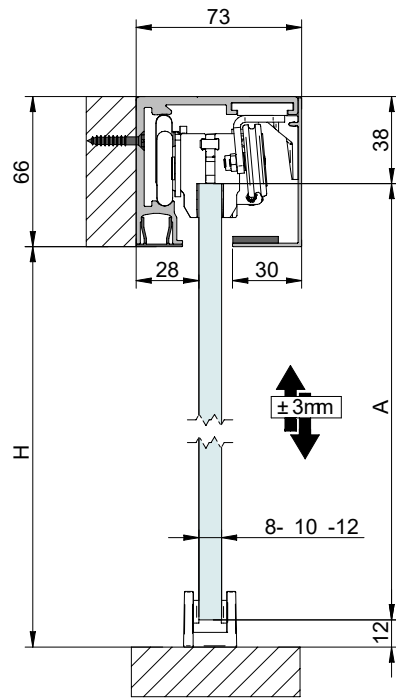

$A=H+16$

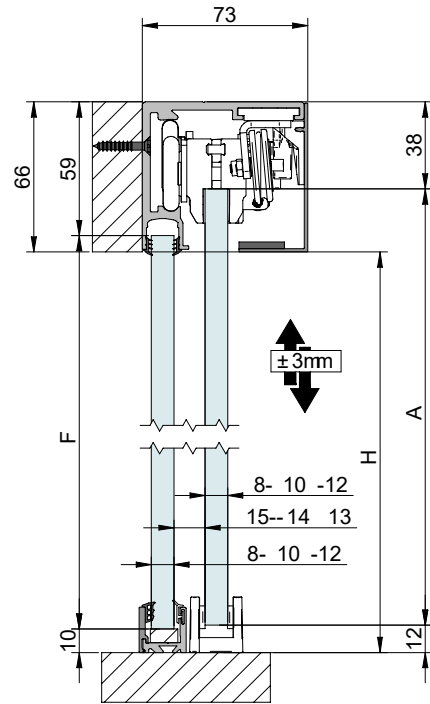

$A=H+16$

$F=H-3$

## /Montaje a techo

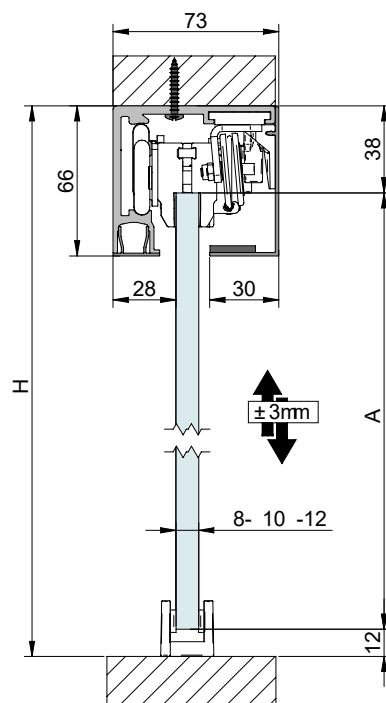

$A=H-50$

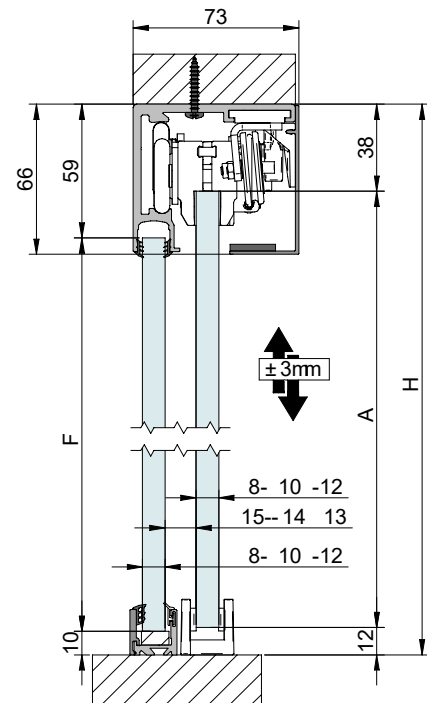

$A=H-50$

$F=H-69$

/Montaje a falso techo

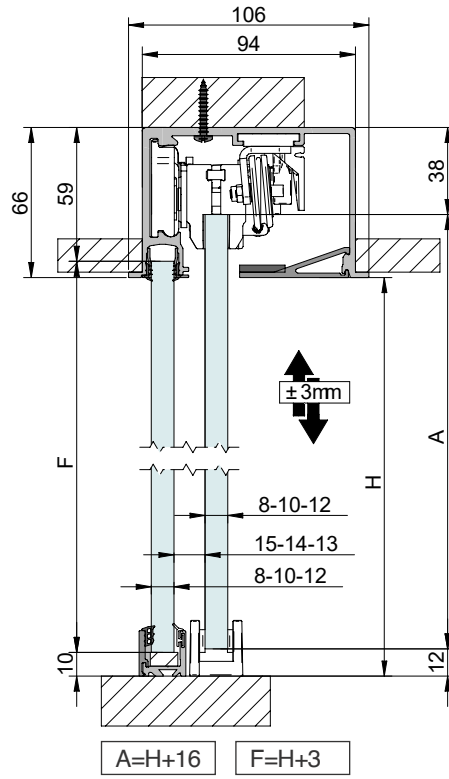
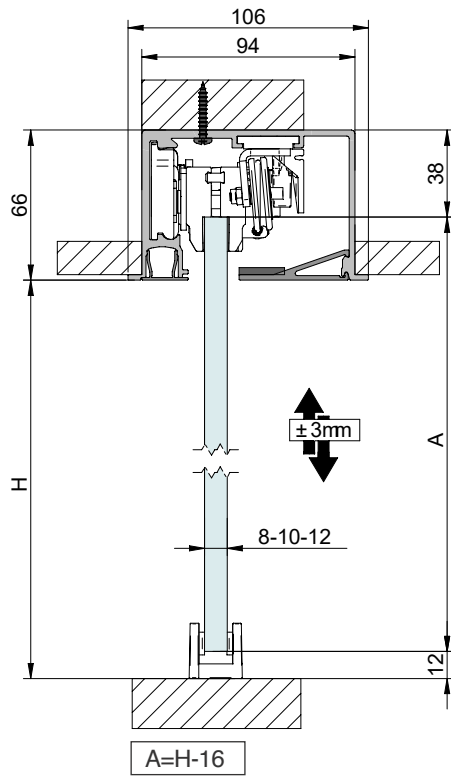

# Componentes

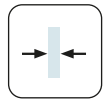

8-10-12 mm

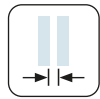

15-14-13 mm

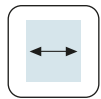

RETENEDOR  
MÍN. 600 mm

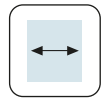

SOFTOP  
MÍN. 685 mm

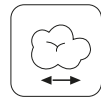

MÁX.55Kg

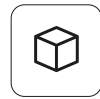

KIT  
DISPONIBLE

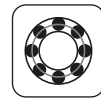

RODAMIENTO  
A BOLAS



Aluminio  
natural



Aluminio  
anodizado  
plata mate



Aluminio  
lacado  
blanco  
mate



Aluminio  
lacado  
negro mate



PVC negro



Plástico  
plata



Plástico  
negro



Plástico  
blanco

10

## /Perfilería

Acabado

Cód.

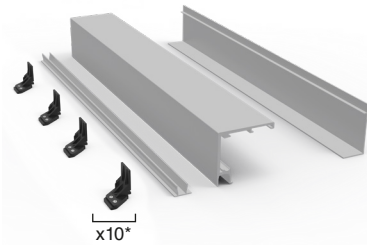

Conjunto perfil superior corredero /  
corredero + vidrio fijo **BLOQ.**



73x66 mm

MF	0 113 23	2 m
	0 113 33	3 m
	0 113 43	4 m
	0 113 63	6 m
S	0 112 20	2 m
	0 112 30	3 m
	0 112 40	4 m
	0 112 60	6 m
WL	0 112 22	2 m
	0 112 32	3 m
	0 112 42	4 m
	0 112 62	6 m
BL	0 112 23	2 m
	0 112 33	3 m
	0 112 43	4 m
	0 112 63	6 m

1 juego

www.sahcco.com

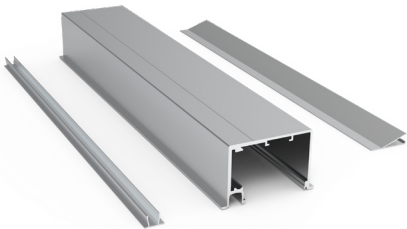

Conjunto perfil superior corredero /  
corredero + vidrio fijo **BLOQ FT.**  
Montaje a falso techo.







106x66 mm

MF	0 113 24	2 m
	0 113 34	3 m
	0 113 44	4 m
	0 113 64	6 m
S	0 112 24	2 m
	0 112 34	3 m
	0 112 44	4 m
	0 112 64	6 m
WL	0 112 25	2 m
	0 112 35	3 m
	0 112 45	4 m
	0 112 65	6 m
BL	0 112 26	2 m
	0 112 36	3 m
	0 112 46	4 m
	0 112 66	6 m



1 juego

/Perfilería

	Acabado	Cód.		
 <p>Tapeta <b>BLOQ Cube</b>.</p>  <p>55x66 mm</p>	MF	0 113 36		
	S	0 113 30	3 m	2 perfiles
	WL	0 113 31		
	BL	0 113 32		

 <p>Tapeta <b>BLOQ Cube FT</b></p>  <p>73x13 mm</p>	MF	0 113 37		
	S	0 113 38	3 m	2 perfiles
	WL	0 113 39		
	BL	0 114 30		

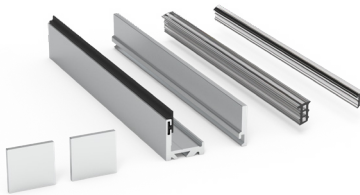
 <p>Perfil inferior para vidrio fijo de 8-10-12mm</p>  <p>20x20 mm</p>	S	00 87 30	3 m	
	WL	00 88 30	3 m	2 perfiles
	BL	00 89 30	3 m	

 <p>Perfil inferior entrada frontal para vidrio fijo de 8-10-12 mm</p>  <p>21x20 mm</p>	S	0 110 32 <sup>1</sup>		
	WL	0 110 34 <sup>1</sup>	3 m	1 juego
	BL	0 110 35 <sup>1</sup>		

<sup>1</sup>El perfil incluye junta + juegos de tapas laterales. 2 m - 2 juegos de tapas 3 m - 4 juegos de tapas 6 m - 6 juegos de tapas

/Juegos

Acabado

Cód.

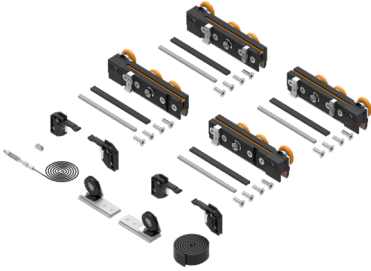

Juego accesorios **SV-Sincro Q110**. x2 Freno retenedor

110kg por hoja



0 110 04

1 juego

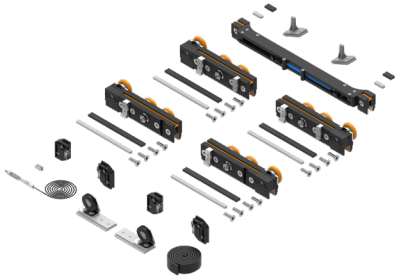

Juego accesorios **SV-Sincro Q110**. x1 SofTop doble

55kg por hoja



0 110 05

1 juego

12

/Accesorios

Acabado

Cód.

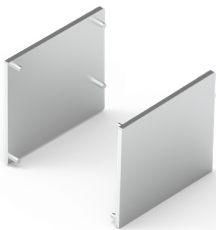

Juego de tapas conjunto para perfil superior.  
Montaje a techo o pared.



73x66 mm

SP

00 70 74

BP

00 70 76

WP

00 70 75

1 juego



SofTop doble **SV-Q110**

110kg

0 110 03

1 pieza

**/Accesorios**

Acabado

Cód.



Clip tapeta perfil superior **BLOQ**  
Ya incluido en juego de perfilera.

0 112 02

10 piezas



Conector guías **SV-Q60 / SV-Q110**

0 112 01

1 pieza



Soporte para pared de vidrio

00 70 84<sup>1</sup>

10 piezas

**13**



Junta transparente PVC



2x8mm



3x11mm



4x11mm

**PVCT**

00 45 82 (3mm)

00 45 87 (3mm)

00 45 84 (4mm)

**PVCB**

00 45 83 (2mm)

00 45 90 (3mm)

00 45 85 (4mm)

1 pieza

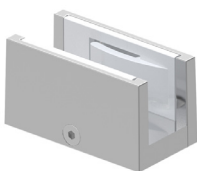

Guiador inferior para vidrio de 8-14mm

**S**

0 155 73

**WL**

00 71 90

**BL**

00 71 80

2 piezas

<sup>1</sup>Para las familias que incorporen soporte pared con perfilera de 2 m, 3 m, 4 m o 6 m, aplicar cada 400mm | 2 m - 6 soportes pared | 3 m - 8 soportes pared

/Kits

Acabado

Cód.

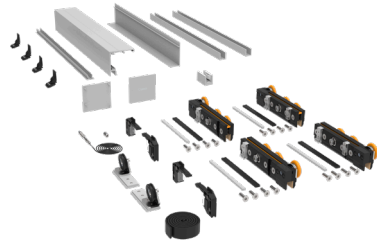

Kit **SV-Sincro Q110**. x2 Freno retenedor  
Con o sin vidrio fijo.

110kg por hoja



73x66 mm

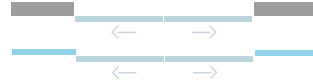

Acabado	Cód.	Longitud	Quantidad
S	0 912 30	3 m	1 kit
	0 912 31	4 m	
BL	0 912 32	3 m	
	0 912 33	4 m	
WL	0 912 34	3 m	
	0 912 35	4 m	

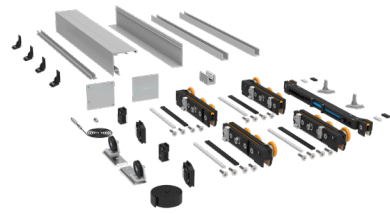

Kit **SV-Sincro Q110**. SofTop doble  
Con o sin vidrio fijo.

55kg por hoja



73x66 mm



Acabado	Cód.	Longitud	Quantidad
S	0 912 36	3 m	1 kit
	0 912 37	4 m	
BL	0 912 38	3 m	
	0 912 39	4 m	
WL	0 912 40	3 m	
	0 912 41	4 m	



## **Multiplo Compact Glass**

**SV-SINCRO X110**

# MULTIPL COMPACT GLASS

BIBLIOTECA  
DE DESCARGAS



DOWNLOADS LIBRARY |  
BIBLIOTHÈQUE  
TÉLÉCHARGEMENTS

## ES

**LA FAMILIA MULTIPL COMPACT GLASS ES LA MEJOR OPCIÓN PARA CERRAR ESPACIOS GRANDES CON MÚLTIPLES HOJAS DE VIDRIO.**

El sistema SV-Sincro X110 permite abrir y cerrar dos hojas de forma simultánea y sincronizada en los dos lados, con la posibilidad de instalar 2 hojas de hasta 110kg.

Además, incorpora como novedad la tecnología **SOFTPRO** de Saheco, una característica que aporta mayor suavidad y seguridad en la apertura y en el cierre de la instalación.

## EN

**THE MULTIPL COMPACT GLASS FAMILY IS THE BEST CHOICE FOR CLOSING LARGE SPACES WITH MULTIPLE GLASS SHEETS WITH AN ATTRACTIVE MINIMALIST DESIGN.**

The SV-Sincro X110 system allows you to open and close two sheets simultaneously and synchronized on both sides, with the possibility of installing 2 sheets of up to 110kg.

In addition, it incorporates as a novelty **SOFTPRO** technology by Saheco, a feature that brings greater smoothness and safety in the opening and closing of the installation.

## FR

**LA FAMILLE MULTIPL COMPACT GLASS, EST LA MEILLEURE OPTION POUR FERMER DE GRANDS ESPACES AVEC DE MULTIPLES PANNEAUX DE VERRE ET AVEC UN ATTRAYANT DESSIN MINIMALISTE.**

Le système SV-Sincro X110 permet ouvrir et fermer deux feuilles simultanément et de manière synchrone sur les deux côtés, et avec la possibilité d'installation des deux feuilles jusqu'à 110 kg.

Il est équipée de la nouvelle fonctionnalité de la technologie **SOFTPRO** Saheco, une fonctionnalité qui vous donne la sécurité et douceur dans l'ouverture et la fermeture de l'installation.





### Características técnicas

Technical characteristics | Caractéristiques techniques

#### Perfilería Profiles | Profils



59x60 mm



59x70 mm

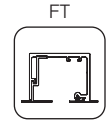

76x61 mm

FT VIDRIO FIJO  
I FIXED GLASS  
I VERRE FIXE



76x61 mm



17x12 mm

#### Especificaciones Specifications | Spécification

VIDRIO FIJO I FIXED  
GLASS I VERRE FIXE  
(Techo I Ceiling I  
Plafond)



10-12 mm



12-11 mm

VIDRIO FIJO I FIXED  
GLASS I VERRE FIXE  
(FT)



21-20 mm

PARED DE VIDRIO  
I GLASS WALL  
I MUR DE VERRE



19-17 mm



SOFTPRO<sup>®</sup>  
MÍN. 740 mm



SOFTPRO<sup>®</sup> DOBLE  
MÍN. 1040 mm



MÁX. 110Kg



RODAMIENTO A BOLAS  
BALL BEARING  
ROULEMENT À BILLES



KIT DISPONIBLE  
I AVAILABLE

#### Peso Weight | Poids

110 kg

242 lb

#### Producto certificado

Certificated product | Produit certifié





# SOFTPRO®

TECHNOLOGY by Saheco



La nueva tecnología **SOFTPRO**® de frenado suave combina la función de dos pistones a gas y un amortiguador de aceite en un único componente.

Ofrece 4 funciones distintas:

- 1.** Velocidad de cierre ajustable.
- 2.** El cierre es progresivo y se ralentiza cuando la puerta se acerca a la posición completamente cerrada.
- 3.** Cierre suave.
- 4.** Enganche resistente a la rotura.

Garantiza un frenado seguro y evita el rebote de la puerta.

Proporciona un movimiento armónico y una amortiguación segura del cierre de la puerta hasta 110 kg.

**SOFTPRO**® the new soft-closing technology from SAHECO which combines two nitrogen gas filled pistons and one oil filled piston all within the same unit.

Features:

- 1.** Fully adjustable closing speed.
- 2.** Closing action is progressive and slows down as the door approaches the fully closed position.
- 3.** Soft Closing.
- 4.** Anti break feature on the trigger.

Ensures safe braking and Prevents bouncing of the door.

Combines an aesthetically pleasing action with safe soft closing for door weights up to 110Kgs.

La nouvelle technologie de freinage **SOFTPRO**® fonctionne grâce à la combinaison de deux pistons à gaz et un amortisseur à huile.

Offre 4 types de fonctions:

- 1.** Ajustement flexible.
- 2.** Frein progressive.
- 3.** Freinege douce.
- 4.** Crochet anti-rupture.

Garanti un freinage fiable évitant le refoulement de la porte.

Apporte un mouvement esthétique et un amortissement fiable de fermeture de porte jusqu'à 110kg.



# SOFTPRO®

TECHNOLOGY by Saheco

## CARACTERÍSTICAS

### SOFTPRO®

Frenado progresivo de los últimos 65mm de recorrido de la puerta, para hojas de hasta 110kg.

## FEATURES

### SOFTPRO®

Progressive soft closing for the last 65mm of the doors travel into the fully closed position for door weights up to a maximum of 110Kgs.

## CARACTÉRISTIQUES

### SOFTPRO®

Freinage progressif de derniers 65mm de parcours de la porte, pour panneaux jusqu'à 110kg.

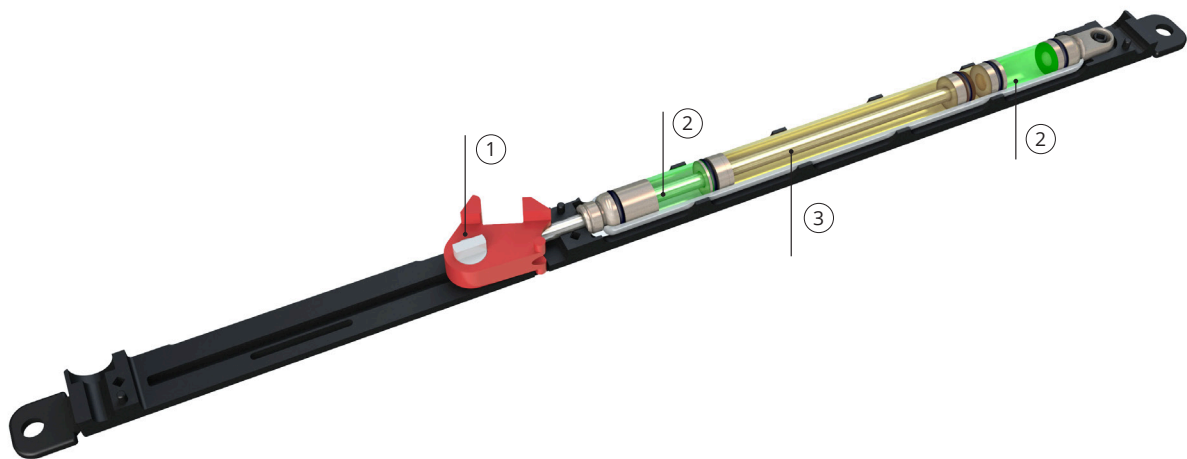

①

**Enganche resistente a la rotura**  
Anti break trigger | Crochet anti rupture

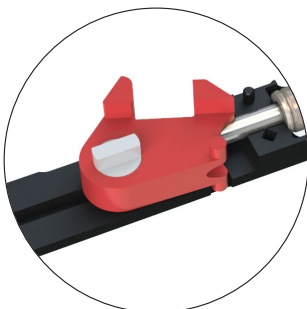

②

**Cámara de nitrógeno**  
Nitrogen gas filled pistons | Chambre azote

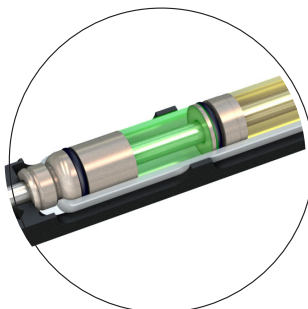

③

**Cámara de amortiguación en aceite**  
Oil filled piston | Piston amortisseur à huile

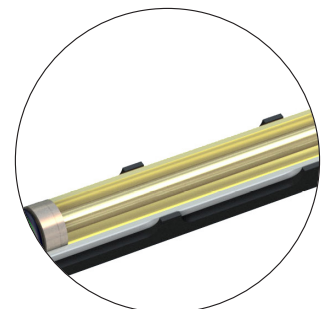



### Variantes de instalación

Installation possibilities | Variantes d'installation

PARED  
WALL  
MUR

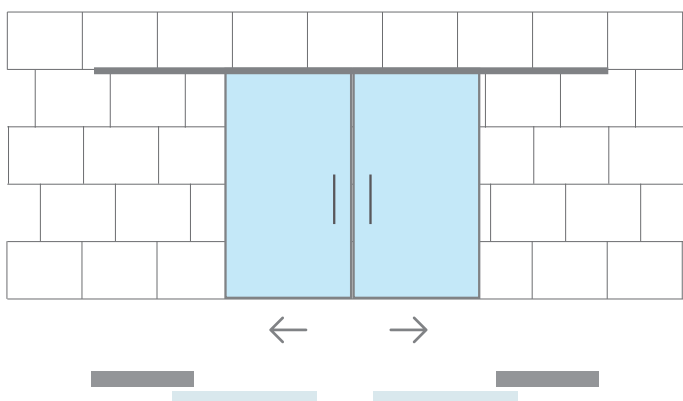

PARED CON VIDRIO FIJO  
WALL WITH FIXED PANEL  
MUR AVEC VERRE FIXE

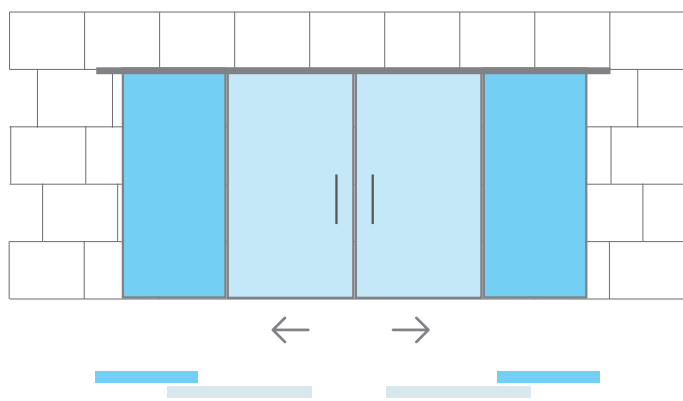

TECHO  
CEILING  
PLAFOND

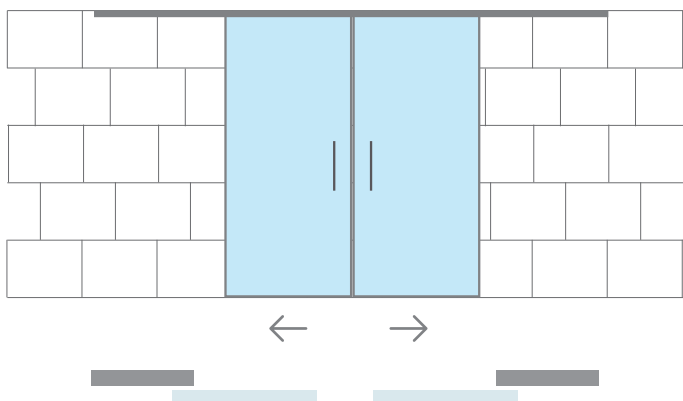

TECHO CON VIDRIO FIJO  
CEILING WITH FIXED PANEL  
PLAFOND AVEC VERRE FIXE

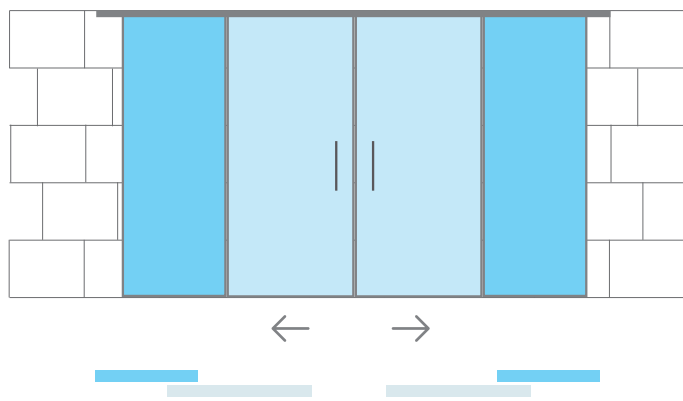

FALSO TECHO  
FALSE CEILING  
FAUX PLAFOND

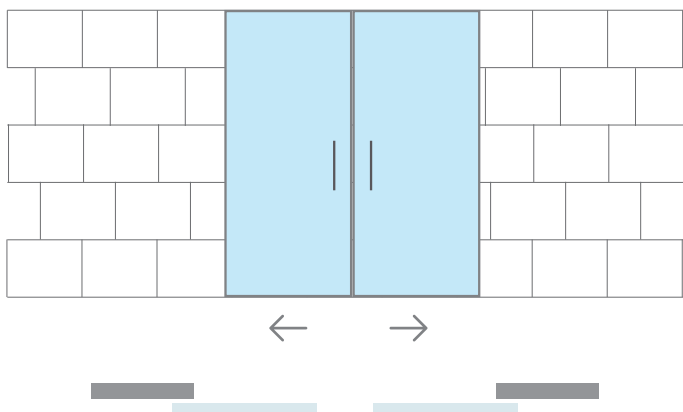

FALSO TECHO CON VIDRIO FIJO  
FALSE CEILING WITH FIXED GLASS  
FAUX PLAFOND AVEC VERRE FIXE

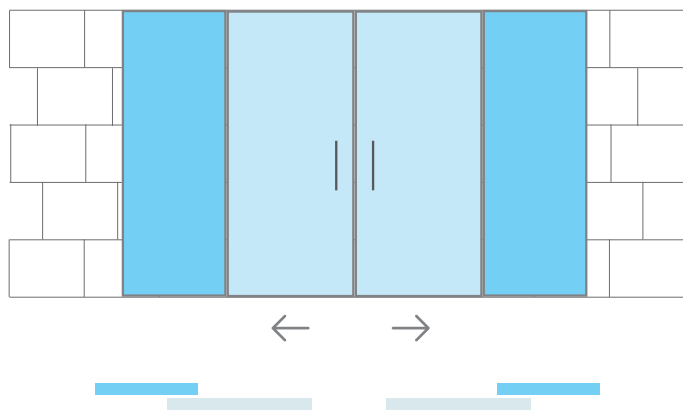

 PUERTA CORREDERA  
SLIDING DOOR / PORTES COULISSANTES

 VIDRIO FIJO  
FIXED GLASS / VERRE FIXE



**Sección tipo**

Cros-section | Section type (Cotas en mm | Dimensions in mm | Dimensions en mm)

**MONTAJE A PARED | WALL MOUNTING | FIXATION À MUR**

**MONTAJE A TECHO | CEILING MOUNTING | FIXATION À PLAFOND**

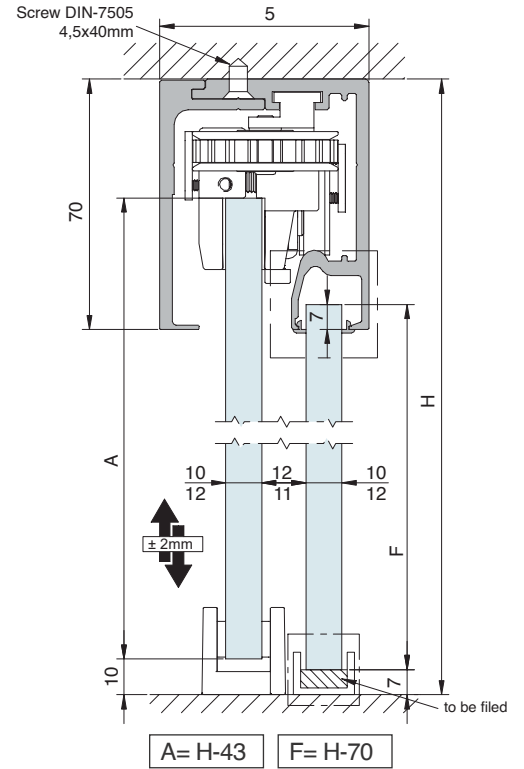
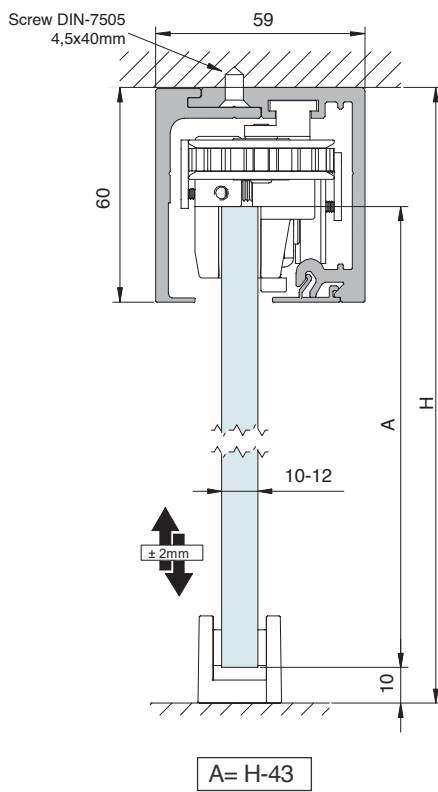
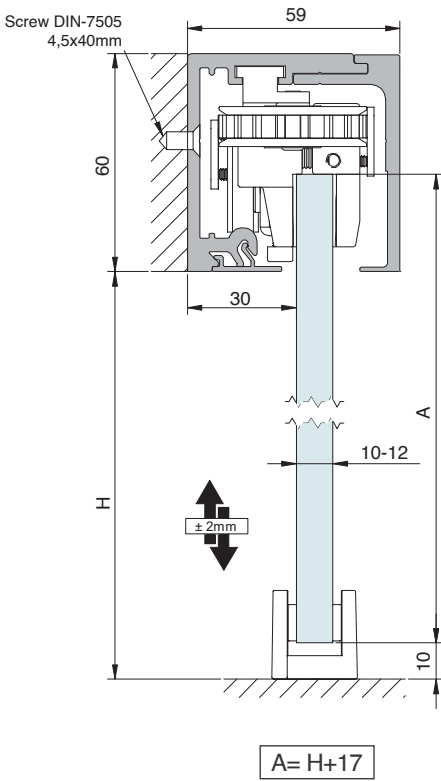



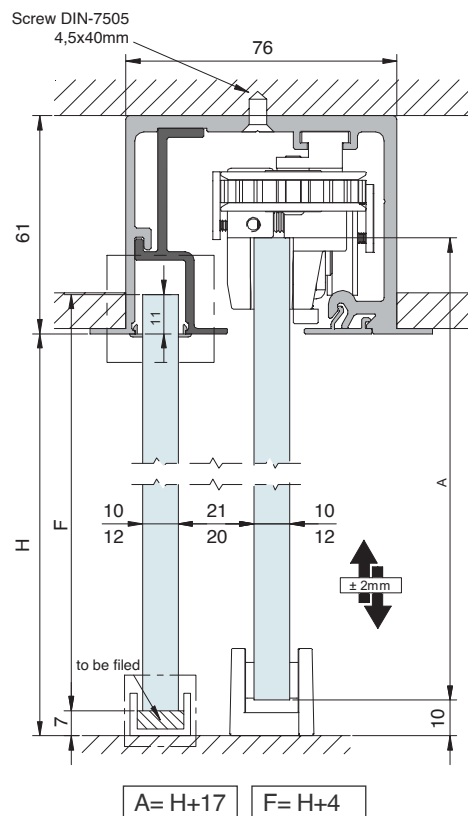
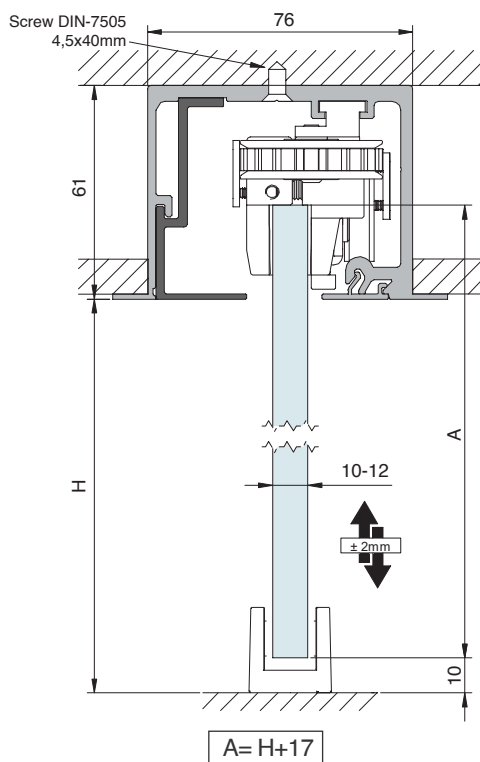



**MONTAJE A FALSO TECHO | FALSE CEILING MOUNTING | FIXATION À FAUX-PLAFOND**



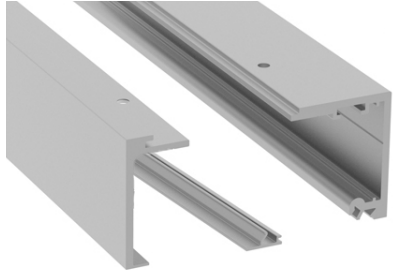

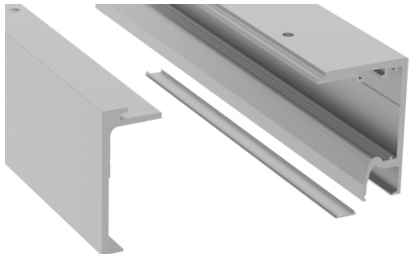
## Componentes

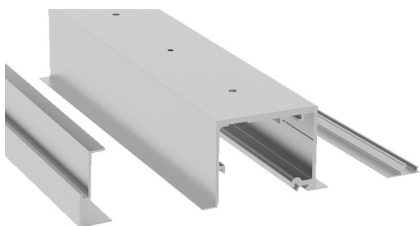
Components | Composants

PERFILERÍA   PROFILES   PROFILS	Acabado	Cód.	-----	📄
 <p>Conjunto perfil superior corredero Sliding top track set Jeu rail supérieur coulissant</p>  <p>59x60mm</p>	S	0 109 20	2 m	1 juego 1 set 1 jeu
		0 109 30	3 m	
		0 109 40	4 m	
		0 109 60	6 m	
	WL	0 119 20	2 m	
		0 119 30	3 m	
		0 119 40	4 m	
		0 119 60	6 m	
	BL	0 119 24	2 m	
		0 119 34	3 m	
		0 119 44	4 m	
		0 119 64	6 m	
 <p>Conjunto perfil superior corredero para vidrio fijo Sliding top track set for fixed glass Jeu rail supérieur coulissant pour verre fixe</p>  <p>59x70mm</p>	S	0 109 22	2 m	1 juego 1 set 1 jeu
		0 109 32	3 m	
		0 109 42	4 m	
		0 109 62	6 m	
	WL	0 119 21	2 m	
		0 119 31	3 m	
		0 119 41	4 m	
		0 119 61	6 m	
	BL	0 119 25	2 m	
		0 119 35	3 m	
		0 119 45	4 m	
		0 119 65	6 m	
 <p>Conjunto perfil superior corredero <b>FT</b>. Montaje a falso techo FT sliding top track set. False ceiling mounting Set rail supérieur coulissant FT. Fixation à faux plafond</p>  <p>76x61mm</p>	S	0 109 24	2 m	1 juego 1 set 1 jeu
		0 109 34	3 m	
		0 109 44	4 m	
		0 109 64	6 m	
	WL	0 119 22	2 m	
		0 119 32	3 m	
		0 119 42	4 m	
		0 119 62	6 m	
	BL	0 119 26	2 m	
		0 119 36	3 m	
		0 119 46	4 m	
		0 119 66	6 m	

**S** Aluminio anodizado plata mate  
Satin anodized aluminium  
Aluminium anodisé argent











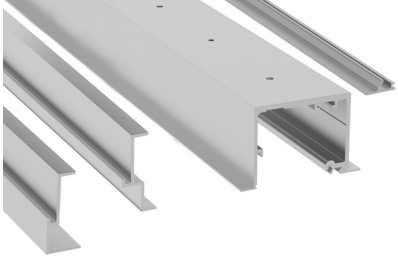

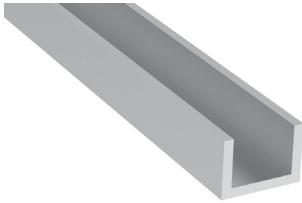
**BL** Aluminio lacado negro mate  
Matt black lacquered aluminium  
Aluminium anodisé laqué noir mat

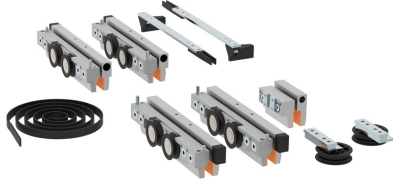
**WL** Aluminio lacado blanco mate  
Matt white lacquered aluminium  
Aluminium anodisé laqué blanc mat



Componentes





Components | Composants

PERFILERÍA   PROFILES   PROFILS		Acabado	Cód.				
 <p>Conjunto perfil superior corredero <b>FT</b> para vidrio fijo. Montaje a falso techo FT sliding top track for fixed glass set. False ceiling mounting Set rail supérieur coulissant pour verre fixe. Fixation à faux plafond</p>  <p>76x61mm</p>	<div style="background-color: black; color: white; padding: 2px; text-align: center; width: 20px; height: 20px; margin: 0 auto;">S</div>	0 109 26	2 m	1 juego 1 set 1 jeu			
		0 109 36	3 m				
		0 109 46	4 m				
		0 109 66	6 m				
	<div style="border: 1px solid black; padding: 2px; text-align: center; width: 20px; height: 20px; margin: 0 auto;">WL</div>	0 119 23	2 m				
		0 119 33	3 m				
		0 119 43	4 m				
		0 119 63	6 m				
	<div style="background-color: black; color: white; padding: 2px; text-align: center; width: 20px; height: 20px; margin: 0 auto;">BL</div>	0 119 27	2 m				
		0 119 37	3 m				
		0 119 47	4 m				
		0 119 67	6 m				
 <p>Perfil inferior para vidrio fijo de 8-10-12mm Bottom track for fixed glass of 8-10-12mm Rail inférieur pour verre fixe 8-10-12mm</p>  <p>17x12mm</p>	<div style="background-color: black; color: white; padding: 2px; text-align: center; width: 20px; height: 20px; margin: 0 auto;">S</div>	00 87 24	2 m	1 perfil 1 profile 1 profil			
		00 87 34	3 m				
		00 87 64	6 m				
	<div style="border: 1px solid black; padding: 2px; text-align: center; width: 20px; height: 20px; margin: 0 auto;">WL</div>	00 71 96	2 m				
		00 71 91	3 m				
		00 71 97	6 m				
	<div style="background-color: black; color: white; padding: 2px; text-align: center; width: 20px; height: 20px; margin: 0 auto;">BL</div>	00 71 86	2 m				
		00 71 81	3 m				
		00 71 87	6 m				
	JUEGOS   SETS   JEUX		Acabado		Cód.		
	 <p>Juego accesorios <b>SV-Sincro X110</b> x2 Freno retenedor SV-Sincro X110 Fitting set x2 Retaining stopper Garniture SV-Sincro X110 x2 Frein de retenue</p> <p><b>110kg</b> por hoja   per panel   par panneaux</p>  <p>RODAMIENTO A BOLAS BALL BEARING ROULEMENT À BILLES</p>		0 109 08			1 juego 1 set 1 jeu	
	 <p>Juego accesorios <b>SV-Sincro X110</b> x2 <b>SOFTPRO</b> 55kg SV-Sincro X110 Fitting set x2 <b>SOFTPRO</b> 55kg Garniture SV-Sincro X110 x2 <b>SOFTPRO</b> 55kg</p> <p><b>55kg</b> por hoja   per panel   par panneaux</p>   <p>RODAMIENTO A BOLAS BALL BEARING ROULEMENT À BILLES</p>		0 109 06			1 juego 1 set 1 jeu	
 <p>Juego accesorios <b>SV-Sincro X110</b> x2 <b>SOFTPRO</b> doble 110kg SV-Sincro X110 Fitting set x2 double <b>SOFTPRO</b> 110kg Garniture SV-Sincro X110 x2 <b>SOFTPRO</b> double 110kg</p> <p><b>110kg</b> por hoja   per panel   par panneaux</p>   <p>RODAMIENTO A BOLAS BALL BEARING ROULEMENT À BILLES</p>		0 109 07		1 juego 1 set 1 jeu			

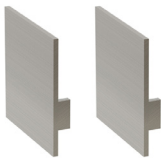
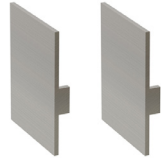
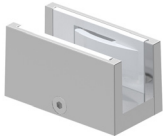

## Componentes

Components | Composants

ACCESORIOS   ACCESSORIES   ACCESSOIRES		Acabado	Cód.			
	<p>Juego de tapas laterales para perfil superior.                      Montaje a techo o pared                      Lateral cap set for top track.                      Ceiling or wall mounting                      Jeu de capuchons latéraux pour rail supérieur.                      Fixation à mur et à plafond</p>	PPS	0 109 90		1 juego 1 set 1 jeu	
		PPSS	0 109 91			
		PPW	0 119 93			
		PPB	0 119 95			
	<p>Juego de tapas laterales para perfil superior para vidrio fijo. Montaje a techo o pared                      Lateral cap set for top track for fixed glass. Ceiling or wall mounting                      Jeu de capuchons latéraux pour rail supérieur pour verre fixe. Fixation à mur et à plafond</p>	PPS	0 109 92		1 juego 1 set 1 jeu	
		PPSS	0 109 93			
		PPW	0 119 94			
		PPB	0 119 96			
			0 155 73			
	<p>Guiador inferior para vidrio de 8-14 mm                      Bottom guide for glass of 8-14mm                      Guide inférieur pour verre de 8-14mm</p>	S	0 155 73		1 pieza 1 piece 1 pièce	
		WL	00 71 90			
		BL	00 71 80			
	<p>Junta transparente PVC                      PVC profile gasket                      Joint d'adaptation PVC</p>  <p>2x8mm   3x11mm   4x11mm</p>		PVCT	00 45 82 (2mm)	1 m	1 pieza 1 piece 1 pièce
				00 45 87 (3mm)		
				00 45 84 (4mm)		
			PVCB	00 45 83 (2mm)		
				00 45 90 (3mm)		
				00 45 85 (4mm)		
	<p>Tornillería sujeción 1 metro de perfil                      Bolts for securing 1 metre of track                      Vis de fixation 1 mètre de rail</p>			0 160 73	1 juego 1 set 1 jeu	



**PPSS** Plástico pintado Inox  
Plastic painted Stainless Steel  
Plastique finition peinture Inox



**BL** Aluminio lacado negro mate  
Matt black lacquered aluminium  
Aluminium anodisé laqué noir mat



**PPW** Plástico pintado blanco  
Plastic painted white  
PVC finition peinture blanche



**WL** Aluminio lacado blanco mate  
Matt white lacquered aluminium  
Aluminium anodisé laqué blanc mat



**PPB** Plástico pintado negro  
Black painted plastic  
PVC peinture noir



**PVCT** PVC transparente  
Transparent PVC  
PVC transparent



**PPS** Plástico pintado plata  
Plastic painted silver  
PVC finition peinture argent



**S** Aluminio anodizado plata mate  
Satin anodized aluminium  
Aluminium anodisé argent







**PVCB** PVC negro  
Black PVC  
PVC noir



Componentes

Components | Composants

KITS   KITS   KITS	Acabado	Cód.	Largo	Cantidad
 <p><b>Kit SV-Sincro X110 x2 Freno retenedor</b> SV-Sincro X110 kit x2 Retaining stopper Kit SV-Sincro X110 x2 Frein de retenue</p> <p><b>110kg</b> por hoja   per panel   par panneaux</p>  59x60mm  RODAMIENTO A BOLAS BALL BEARING ROULEMENT À BILLES 	S	0 910 25 0 910 27	3 m 4 m	1 kit 1 jeu
 <p><b>Kit SV-Sincro X110 SOFTPRO® 55kg</b> SV-Sincro X110 kit SOFTPRO® 55kg Kit SV-Sincro X110 SOFTPRO® 55kg</p> <p><b>55kg</b> por hoja   per panel   par panneaux</p>  59x60mm  RODAMIENTO A BOLAS BALL BEARING ROULEMENT À BILLES  SOFTPRO 	S	0 910 29 0 910 31	3 m 4 m	1 kit 1 jeu
 <p><b>Kit SV-Sincro X110 x2 SOFTPRO® doble 110kg</b> SV-Sincro X110 kit x2 double SOFTPRO® 110kg Kit SV-Sincro X110 x2 SOFTPRO® double 110kg</p> <p><b>110kg</b> por hoja   per panel   par panneaux</p>  59x60mm  RODAMIENTO A BOLAS BALL BEARING ROULEMENT À BILLES  SOFTPRO 	S	0 910 59	4 m	1 kit 1 jeu

**Componentes**

Components | Composants

KITS   KITS   KITS		Acabado	Cód.		
	<p>Kit <b>SV-Sincro X110</b> para vidrio fijo x2 Freno retenedor                      SV-Sincro X110 kit for fixed glass x2 Retaining stopper                      Kit SV-Sincro X110 pour verre fixe x2 Frein de retenue</p> <p><b>110kg</b> por hoja   per panel   par panneaux</p>  59x70mm  RODAMIENTO A BOLAS BALL BEARING ROULEMENT À BILLES	S	0 910 33 0 910 35	3 m 4 m	1 kit 1 jeu
	<p>Kit <b>SV-Sincro X110</b> para vidrio fijo x2 <b>SOFTPRO</b> 55kg                      SV-Sincro X110 kit for fixed glass x2 <b>SOFTPRO</b> 55kg                      Kit SV-Sincro X110 pour verre fixe x2 <b>SOFTPRO</b> 55kg</p> <p><b>55kg</b> por hoja   per panel   par panneaux</p>  59x70mm  RODAMIENTO A BOLAS BALL BEARING ROULEMENT À BILLES  <b>SOFTPRO</b>	S	0 910 37 0 910 39	3 m 4 m	1 kit 1 jeu
	<p>Kit <b>SV-Sincro X110</b> para vidrio fijo x2 <b>SOFTPRO</b> doble 110kg                      SV-Sincro X110 kit for fixed glass x2 double <b>SOFTPRO</b> 110kg                      Kit SV-Sincro X110 pour verre fixe x2 <b>SOFTPRO</b> double 110kg</p> <p><b>110kg</b> por hoja   per panel   par panneaux</p>  59x70mm  RODAMIENTO A BOLAS BALL BEARING ROULEMENT À BILLES  <b>SOFTPRO</b>	S	0 910 63	4 m	1 kit 1 jeu



# Multiplo Compact Glass

SV-T-PRO X110

(TELESCÓPICA | TELESCOPIC | TELÉSCOPIQUE)

# MULTIPLIO COMPACT GLASS

BIBLIOTECA  
DE DESCARGAS



DOWNLOADS LIBRARY |  
BIBLIOTHÈQUE  
TÉLÉCHARGEMENTS

— ES

La familia Multiplo Compact Glass es la mejor opción para cerrar espacios grandes con múltiples hojas de vidrio. Ésta familia incorpora como novedad la tecnología **SOFTPRO**® de Saheco, una característica que aporta mayor suavidad y seguridad en la apertura y en el cierre de la instalación.

SV-T-PRO X110 permite colocar 2 hojas de hasta 110kg por hoja con el objetivo de recogerlas en un único lado de la instalación, bien a izquierda o bien a derecha. La apertura y el cierre se desarrollan de forma suave arrastrando las dos puertas con un solo movimiento.

Ésta familia tiene dos acabados disponibles: Aluminio anodizado plata mate y Aluminio cepillado acabado Inox.

Además, el sistema ha sido probado en 100.000 ciclos según normativa europea EN1527 / EN1670.

— EN

The Multiplo Compact Glass family is the best choice for closing large spaces with multiple sheets of glass. This family incorporates the new **SOFTPRO**® technology of Saheco, a characteristic that brings greater smoothness and security in the opening and closing of the installation.

SV-T-PRO X110 allows you to place 2 sheets of up to 110kg per sheet with the aim of collecting them on a single side of the installation, either left or right. The opening and the closing are developed smoothly dragging the two doors with a single movement.

This family has two finishes available: Matte silver anodized aluminum and Brushed aluminum finish. In addition, the system has been tested in 100,000 cycles according to European regulations EN1527 / EN1670.

— FR

La gamme Multiplo Compact verre est la meilleure option pour fermer de grands espaces avec de multiples panneaux de verre. Cette nouvelle famille, incorpore la nouvelle technologie **SOFTPRO**® SAHECO avec une fonctionnalité qui vous donne plus sécurité dans l'ouverture et la fermeture de l'installation.

SV-T-PRO X110 permet de placer 2 feuilles de jusqu'à 110 kg chaque, afin de recueillir sur un côté de l'installation, soit à gauche ou à droite. L'ouverture et la fermeture se développent en faisant glisser doucement les deux portes en un seul mouvement.

Cette système a deux finitions: anodisé argent mat en aluminium et finition en aluminium brossé Inox. En outre, le système a été testé dans 100.000 cycles selon la norme européenne EN1527 / EN1670.





### Características técnicas

Technical characteristics | Caractéristiques techniques

#### Perfilería Profiles | Profils

TECHO | CEILING | PLAFOND  
Con/sin vidrio fijo | With/without fixed glass | Avec/sans verre fixe



10 mm - 103x70 mm  
12 mm - 107x70 mm

FALSO TECHO | FALSE CEILING | FAUX-PLAFOND  
Con/sin vidrio fijo | With/without fixed glass | Avec/sans verre fixe

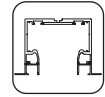

10 mm - 103x87 mm  
12 mm - 107x87 mm



17x12 mm

#### Especificaciones Specifications | Spécification

VIDRIO FIJO | FIXED GLASS | VERRE FIXE

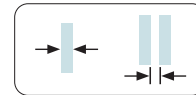

10 mm 12 mm  
12 mm 11 mm

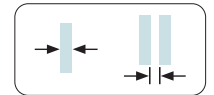

10-12 mm 20 mm



**SOFTPRO**  
DOBLE  
MÍN. 970 mm



**SOFTPRO**  
SIMPLE  
MÍN. 672 mm

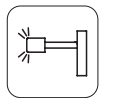

ANTI-SHOCK



MÁX. 110Kg



RODAMIENTO A BOLAS  
BALL BEARING  
ROULEMENT À BILLES



KIT DISPONIBLE  
I AVAILABLE

#### Peso Weight | Poids

110 kg

242 lb

#### Producto certificado

Certificaded product | Produit certifié





# SOFTPRO®

TECHNOLOGY by Saheco



La nueva tecnología **SOFTPRO**® de frenado suave combina la función de dos pistones a gas y un amortiguador de aceite en un único componente.

Ofrece 4 funciones distintas:

- 1.** Velocidad de cierre ajustable.
- 2.** El cierre es progresivo y se ralentiza cuando la puerta se acerca a la posición completamente cerrada.
- 3.** Cierre suave.
- 4.** Enganche resistente a la rotura.

Garantiza un frenado seguro y evita el rebote de la puerta.

Proporciona un movimiento armónico y una amortiguación segura del cierre de la puerta hasta 110 kg.

**SOFTPRO**® the new soft-closing technology from SAHECO which combines two nitrogen gas filled pistons and one oil filled piston all within the same unit.

Features:

- 1.** Fully adjustable closing speed.
- 2.** Closing action is progressive and slows down as the door approaches the fully closed position.
- 3.** Soft Closing.
- 4.** Anti break feature on the trigger.

Ensures safe braking and Prevents bouncing of the door.

Combines an aesthetically pleasing action with safe soft closing for door weights up to 110Kgs.

La nouvelle technologie de freinage **SOFTPRO**® fonctionne grâce à la combinaison de deux pistons à gaz et un amortisseur à huile.

Offre 4 types de fonctions:

- 1.** Ajustement flexible.
- 2.** Frein progressive.
- 3.** Freinege douce.
- 4.** Crochet anti-rupture.

Garanti un freinage fiable évitant le refoulement de la porte.

Apporte un mouvement esthétique et un amortissement fiable de fermeture de porte jusqu'à 110kg.



# SOFTPRO<sup>®</sup>

TECHNOLOGY by Saheco

## CARACTERÍSTICAS

### SOFTPRO<sup>®</sup>

Frenado progresivo de los últimos 65mm de recorrido de la puerta, para hojas de hasta 110kg.

## FEATURES

### SOFTPRO<sup>®</sup>

Progressive soft closing for the last 65mm of the doors travel into the fully closed position for door weights up to a maximum of 110Kgs.

## CARACTÉRISTIQUES

### SOFTPRO<sup>®</sup>

Freinage progressif de derniers 65mm de parcours de la porte, pour panneaux jusqu'à 110kg.

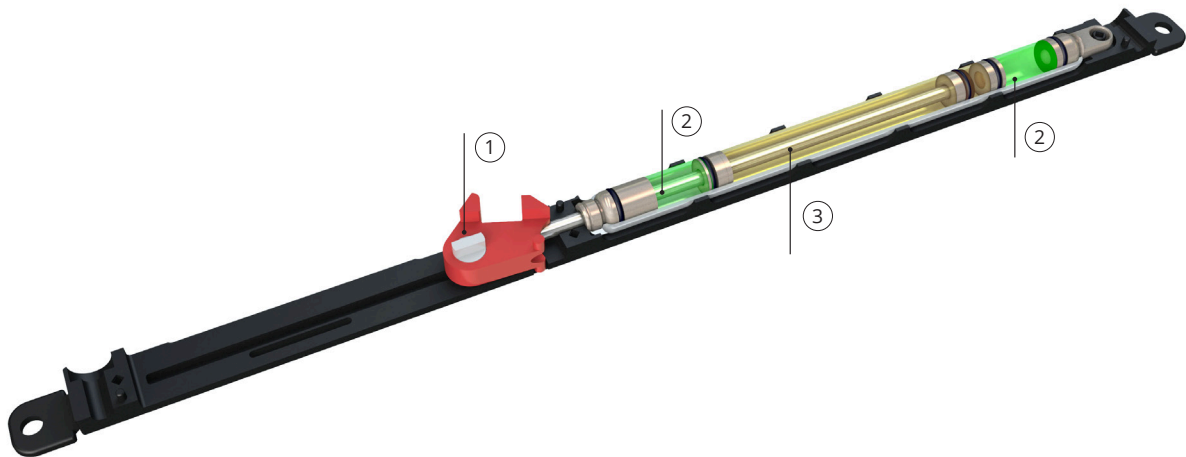

①

**Enganche resistente a la rotura**  
Anti break trigger | Crochet anti rupture

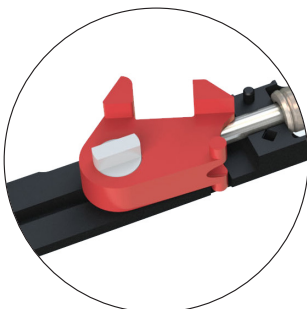

②

**Cámara de nitrógeno**  
Nitrogen gas filled pistons | Chambre azote

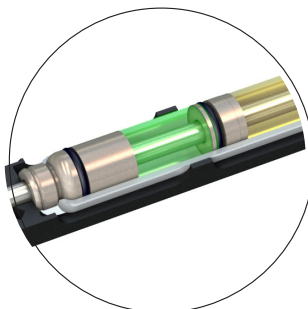

③

**Cámara de amortiguación en aceite**  
Oil filled piston | Piston amortisseur à huile

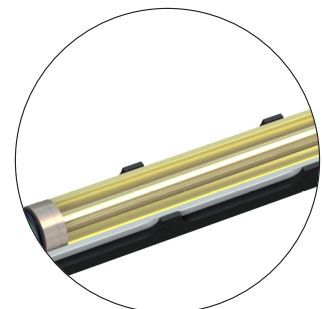

**Variantes de instalación**

Installation possibilities | Variantes d'installation

TECHO  
CEILING  
PLAFOND

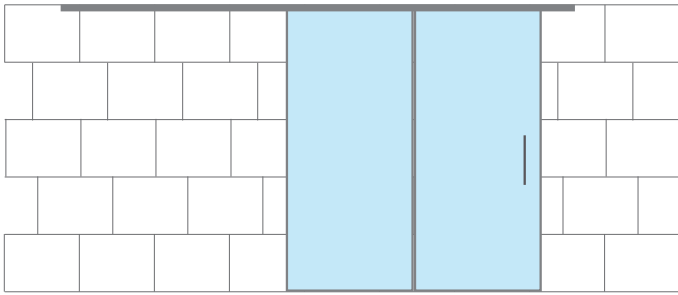

TECHO CON VIDRIO FIJO  
CEILING WITH FIXED PANEL  
PLAFOND AVEC VERRE FIXE

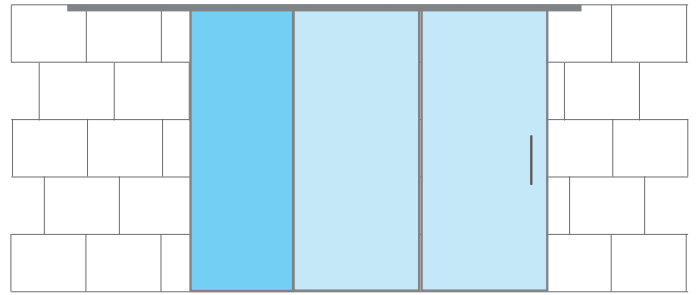

TECHO 2+2  
CEILING 2+2  
PLAFOND 2+2

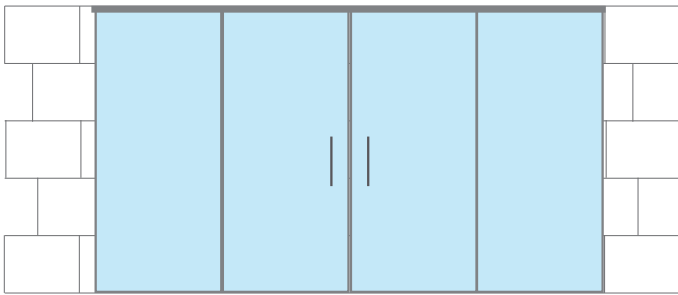

TECHO 2+2 CON VIDRIO FIJO  
CEILING 2+2 WITH FIXED PANEL  
PLAFOND 2+2 AVEC VERRE FIXE



 PUERTA CORREDERA  
SLIDING DOOR / PORTES COULISSANTES

 VIDRIO FIJO  
FIXED GLASS / VERRE FIXE



**Sección tipo**

Cros-section | Section type (Cotas en mm | Dimensions in mm | Dimensions en mm)

FALSO TECHO  
FALSE CEILING  
FAUX PLAFOND

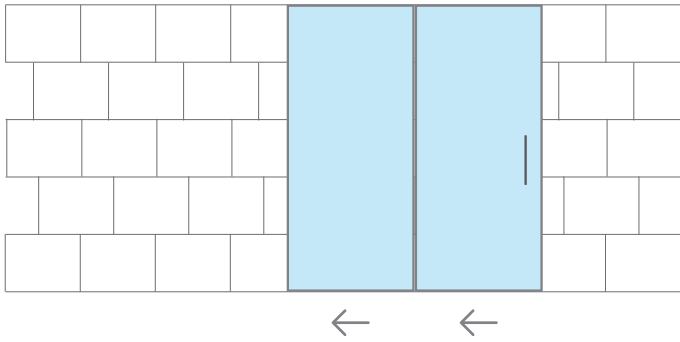

FALSO TECHO 2+2  
FALSE CEILING 2+2  
FAUX PLAFOND 2+2

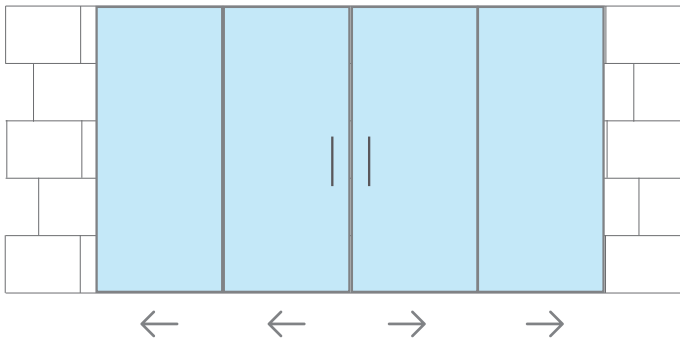

FALSO TECHO 2+2 CON VIDRIO FIJO  
FALSE CEILING 2+2 WITH FIXED PANEL  
FAUX PLAFOND 2+2 AVEC VERRE FIXE

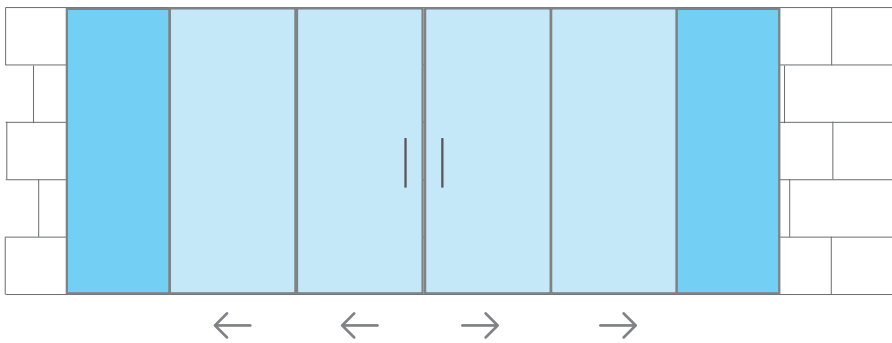

 PUERTA CORREDERA  
SLIDING DOOR / PORTES COULISSANTES

 VIDRIO FIJO  
FIXED GLASS / VERRE FIXE

**Sección tipo**

Cross-section | Section type (Cotas en mm | Dimensions in mm | Dimensions en mm)

**MONTAJE A TECHO** | CEILING MOUNTING | FIXATION À PLAFOND

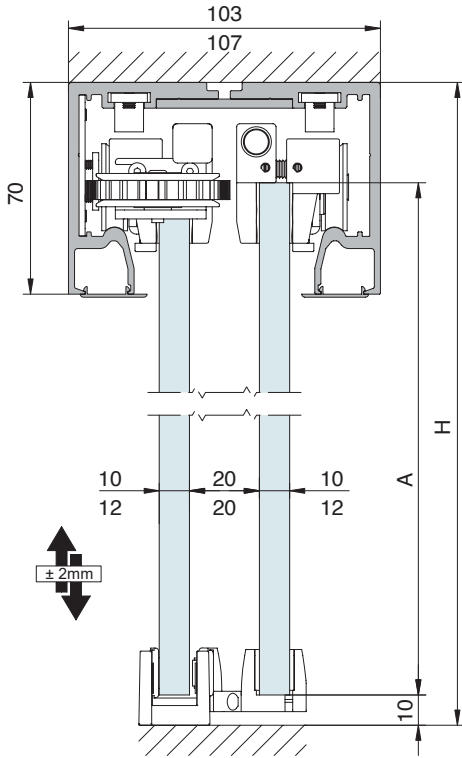

A= H-43

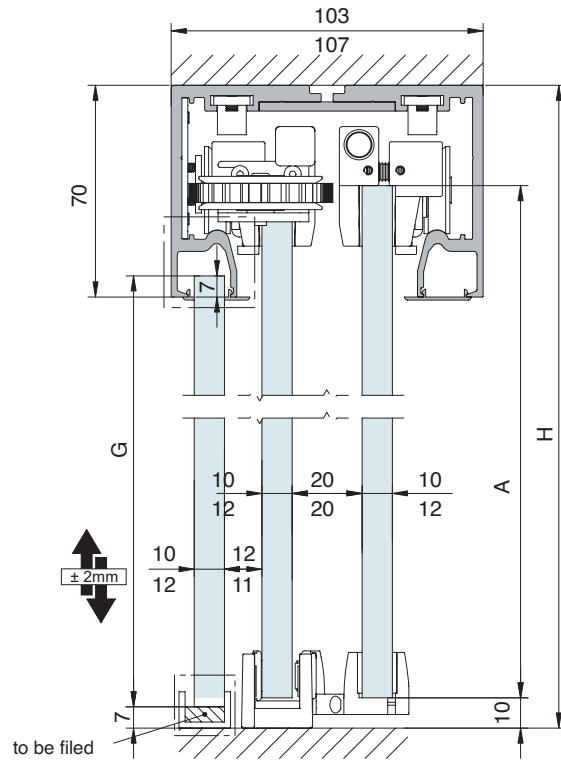

A= H-43

= H-70



**Sección tipo**

Cros-section | Section type (Cotas en mm | Dimensions in mm | Dimensions en mm)

MONTAJE A FALSO TECHO | FALSE CEILING MOUNT | FIXATION À FAUX PLAFOND

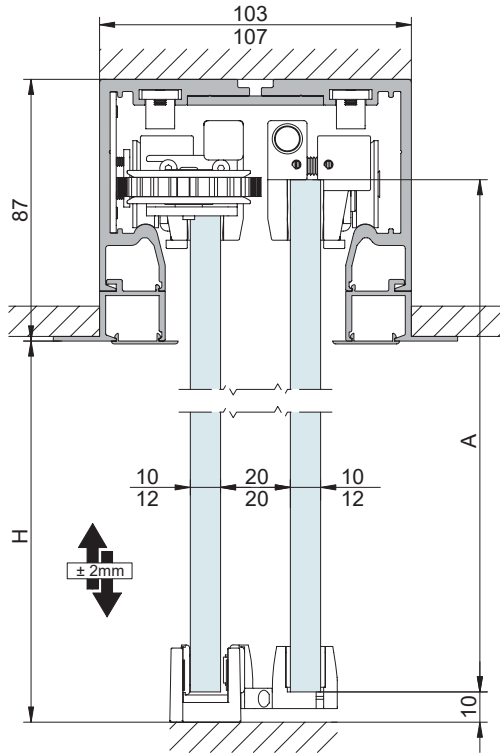

$A = H + 43$

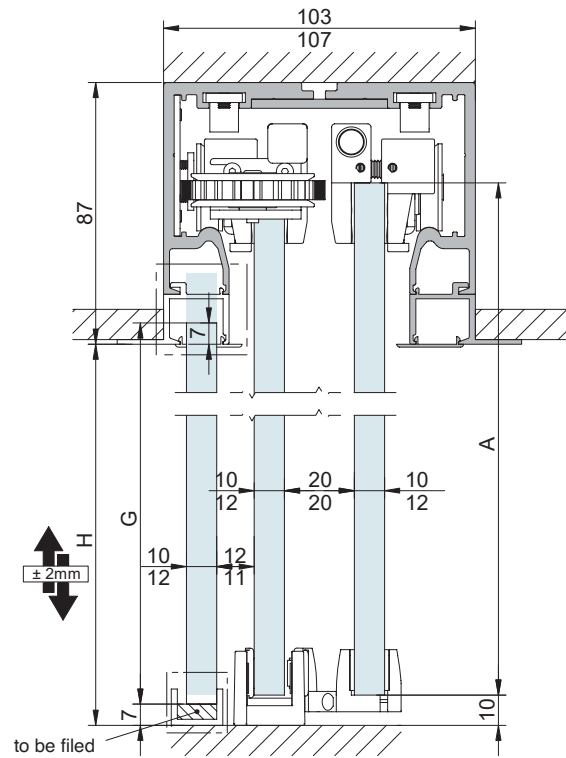









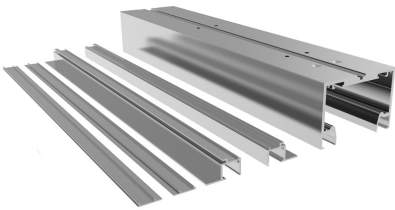
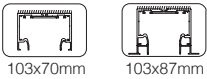





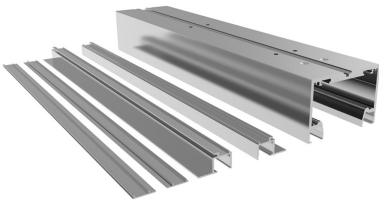
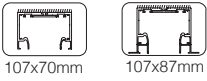

$A = H + 43$

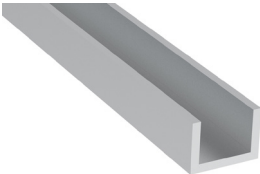
$G = H$

**Componentes**

Components | Composants

PERFILERÍA   PROFILES   PROFILS	Acabado	Cód.		
 <p>Conjunto perfil superior con/sin vidrios fijos (10mm). Montaje a techo o falso techo                      Top track set with/without fixed glass (10mm). Ceiling or false ceiling mounting                      Jeu rail supérieur avec/sans verre fixe (10mm). Fixation à plafond ou à faux plafond</p>  <p>103x70mm    103x87mm</p>	 S   BL   WL	0 109 38    3 m 0 109 48    4 m 0 109 68    6 m		  1 juego 1 set 1 jeu
		0 110 36    3 m 0 110 46    4 m 0 110 56    6 m		
		0 110 41    3 m 0 110 42    4 m 0 110 43    6 m		
 <p>Conjunto perfil superior con/sin vidrios fijos (12mm). Montaje a techo o falso techo                      Top track set with/without fixed glass (12mm). Ceiling or false ceiling mounting                      Jeu rail supérieur avec/sans verre fixe (12mm). Fixation à plafond ou à faux plafond</p>  <p>107x70mm    107x87mm</p>	 S   BL   WL	0 109 70    3 m 0 109 72    4 m 0 109 74    6 m		1 juego 1 set 1 jeu
		0 110 37    3 m 0 110 47    4 m 0 110 67    6 m		
		0 110 45    3 m 0 110 49    4 m 0 110 48    6 m		
 <p>Perfil inferior para vidrio fijo de 8-10-12mm                      Bottom track for fixed glass of 8-10-12mm                      Rail inférieur pour verre fixe de 8-10-12mm</p>  <p>17x12mm</p>	 S   BL   WL	00 87 34		1 perfil 1 profile 1 profil
		00 71 81		
		00 71 91		

 **Aluminio anodizado plata mate**  
 Satin anodized aluminium  
 Aluminium anodisé argent









 **Aluminio lacado negro mate**  
 Matt black lacquered aluminium  
 Aluminium anodisé laqué noir mat

 **Aluminio lacado blanco**  
 White lacquered aluminium  
 Aluminium anodisé laqué blanc

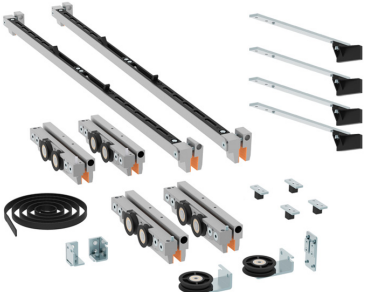

Componentes

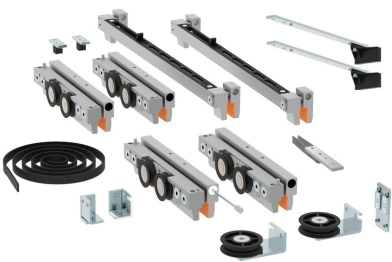
Components | Composants

JUEGOS   SETS   JEUX	Acabado	Cód.		
 <p>Juego accesorios <b>SV-T-PRO X110</b> x2 Freno retenedor SV-T-PRO X110 fitting set x2 Retaining stopper Garniture SV-T-PRO X110 x2 Frein de retenue</p> <p><b>110kg</b> por hoja   per panel   par panneaux</p>  <p>RODAMIENTO A BOLAS BALL BEARING ROULEMENT À BILLES</p>		0 109 12		1 juego 1 set 1 jeu
 <p>Juego accesorios <b>SV-T-PRO X110</b> x2 <b>SOFTPRO</b> doble 110kg SV-T-PRO X110 Fitting set x2 double <b>SOFTPRO</b> 110kg Garniture SV-T-PRO X110 x2 <b>SOFTPRO</b> double 110kg</p> <p><b>110kg</b> por hoja   per panel   par panneaux</p>   <p>RODAMIENTO A BOLAS BALL BEARING ROULEMENT À BILLES</p>		0 109 13		1 juego 1 set 1 jeu
 <p>Juego accesorios SV-T-PRO X110 x1 <b>SOFTPRO</b> 110kg + x1 Anti-shock SV-T-PRO X110 Fitting set with x1 <b>SOFTPRO</b> 110kg + x1 Anti-shock Garniture SV-T-PRO X110 avec x1 <b>SOFTPRO</b> 110kg + x1 Anti-shock</p> <p><b>110kg</b> por hoja   per panel   par panneaux</p>   <p>RODAMIENTO A BOLAS BALL BEARING ROULEMENT À BILLES</p>		0 109 17		1 juego 1 set 1 jeu



## Componentes

Components | Composants

ACCESORIOS   ACCESSORIES   ACCESSOIRES		Acabado	Cód.	1 m	
	<p>Juego guidores inferiores <b>SV-T-PRO X110</b>                      SV-T-PRO X110 Bottom guides set                      Jeu guides inférieurs SV-T-PRO X110</p>	<p><b>S</b></p> <p><b>BA</b></p>	<p>0 109 14</p> <p>0 109 99</p>		<p>1 juego 1 set 1 jeu</p>
	<p>Junta transparente PVC                      PVC profile gasket                      Joint d'adaptation PVC</p> <p> </p> <p>2x8mm 3x11mm 4x11mm</p>	<p><b>PVCT</b></p> <p><b>PVCB</b></p>	<p>00 45 82 (2mm)</p> <p>00 45 87 (3mm)</p> <p>00 45 84 (4mm)</p> <p>00 45 83 (2mm)</p> <p>00 45 90 (3mm)</p> <p>00 45 85 (4mm)</p>	1 m	<p>1 pieza 1 piece 1 pièce</p>
	<p>Juego de tapas laterales para perfil superior con/sin virios fijos 12mm. Montaje a techo o falso techo                      Lateral cap set for top track with/without fixed glass 12mm. Ceiling or false ceiling mounting                      Jeu de capuchons latéraux pour rail supérieur avec/sans verre fixe 12mm. Fixation à plafond ou à faux plafond.</p>	<p><b>S</b></p> <p><b>BL</b></p> <p><b>WL</b></p>	<p>0 109 18</p> <p>0 109 29</p> <p>0 110 59</p>		<p>1 juego 1 set 1 jeu</p>
	<p>Juego de tapas laterales para perfil superior con/sin virios fijos 10mm. Montaje a techo o falso techo                      Lateral cap set for top track with/without fixed glass 10mm. Ceiling or false ceiling mounting                      Jeu de capuchons latéraux pour rail supérieur avec/sans verre fixe 10mm. Fixation à plafond ou à faux plafond.</p>	<p><b>S</b></p> <p><b>BL</b></p> <p><b>WL</b></p>	<p>0 109 77</p> <p>0 109 79</p> <p>0 110 58</p>		<p>1 juego 1 set 1 jeu</p>

**S** Aluminio anodizado plata mate  
 Satin anodized aluminium  
 Aluminium anodisé argent

**BA** Aluminio anodizado negro  
 Black anodized aluminium  
 Aluminium anodisé noir









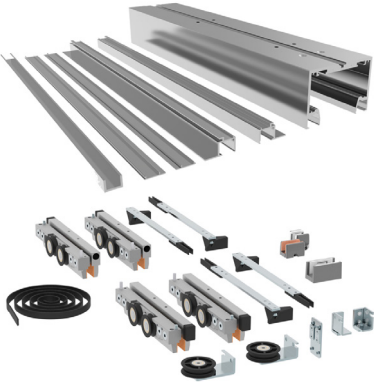

**PVCT** PVC transparente  
 Transparent PVC  
 PVC transparent

**PVCB** PVC negro  
 Black PVC  
 PVC noir

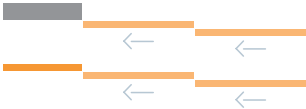

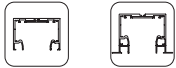

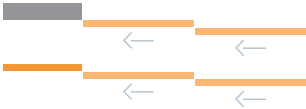
Componentes

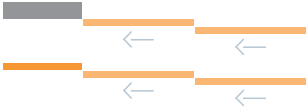
Components | Composants

KITS   KITS   KITS	Acabado	Cód.		
 <p>Kit <b>SV-T-PRO X110</b> con/sin vidrios fijos (10mm) x2 Freno retenedor. Montaje a techo o falso techo SV-T-PRO X110 kit with/without fixed glass (10mm) x2 Retaining stopper. Ceiling or false ceiling mounting Kit SV-T-PRO X110 avec/sans verre fixe (10mm) x2 Frein de retenue. Fixation à plafond ou à faux plafond</p> <p><b>110kg</b> por hoja   per panel   par panneaux</p>   <p>RODAMIENTO A BOLAS BALL BEARING ROULEMENT À BILLES</p> 	<p><b>S</b></p>	<p>0 910 41 0 910 43</p>	<p>3 m 4 m</p>	<p>1 kit 1 jeu</p>
 <p>Kit <b>SV-T-PRO X110</b> con/sin vidrios fijos (10mm) x2 <b>SOFTPRO</b> doble 110kg. Montaje a techo o falso techo SV-T-PRO X110 kit with/without fixed glass (10mm) x2 double <b>SOFTPRO</b> 110kg. Ceiling or false ceiling mounting Kit SV-T-PRO X110 avec/sans verre fixe (10mm) x2 <b>SOFTPRO</b> double 110kg. Fixation à plafond ou à faux plafond</p> <p><b>110kg</b> por hoja   per panel   par panneaux</p>    <p>RODAMIENTO A BOLAS BALL BEARING ROULEMENT À BILLES</p> 	<p><b>S</b></p>	<p>0 910 65 0 910 67</p>	<p>3 m 4 m</p>	<p>1 kit 1 jeu</p>
 <p>Kit <b>SV-T-PRO X110</b> con/sin vidrios fijos (12mm). x2 Freno retenedor. Montaje a techo o falso techo SV-T-PRO X110 kit with/without fixed glass (12mm). x2 Retaining stopper. Ceiling or false ceiling mounting Kit SV-T-PRO X110 avec/sans verre fixe (12mm). x2 Frein de retenue. Fixation à plafond ou à faux plafond</p> <p><b>110kg</b> por hoja   per panel   par panneaux</p>   <p>RODAMIENTO A BOLAS BALL BEARING ROULEMENT À BILLES</p> 	<p><b>S</b></p>	<p>0 910 49 0 910 51</p>	<p>3 m 4 m</p>	<p>1 kit 1 jeu</p>

**Componentes**

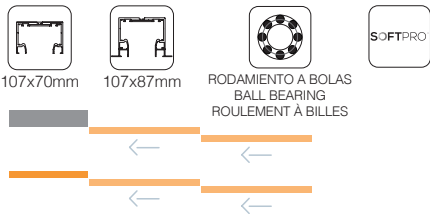
Components | Composants

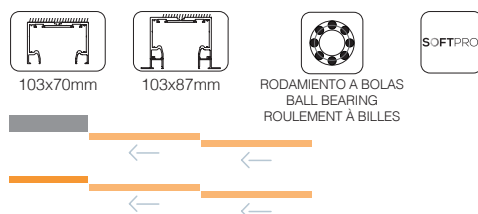
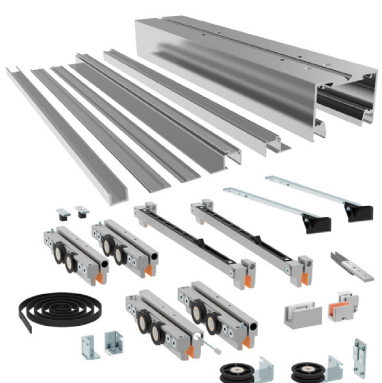
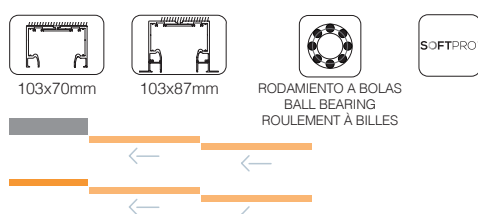
KITS   KITS   KITS		Acabado	Cód.		
	<p>Kit SV-T-PRO X110 con/sin vidrios fijos (12mm)                      x2 <b>SOFTPRO</b>® doble 110kg. Montaje a techo o falso techo                      SV-T-PRO X110 kit with/without fixed glass (12mm)                      x2 double <b>SOFTPRO</b>® 110kg. Ceiling or false ceiling mounting                      Kit SV-T-PRO X110 avec/sans verre fixe (12mm)                      x2 <b>SOFTPRO</b>® double 110kg. Fixation à plafond ou à faux plafond</p> <p><b>110kg</b> por hoja   per panel   par panneaux</p>  <p>107x70mm    107x87mm    RODAMIENTO A BOLAS                      BALL BEARING                      ROULEMENT À BILLES</p> <p><b>SOFTPRO</b></p>	<b>S</b>	0 910 69 0 910 71	3 m 4 m	1 kit 1 jeu
	<p>Kit SV-T-PRO X110 con/sin vidrios fijos (10mm)                      x2 <b>SOFTPRO</b>® 110kg + x1 Anti-shock. Montaje a techo o falso techo                      SV-T-PRO X110 kit with/without fixed glass (10mm)                      x2 <b>SOFTPRO</b>® 110kg + x1 Anti-shock. Ceiling or false ceiling mounting                      Kit SV-T-PRO X110 avec/sans verre fixe (10mm)                      x2 <b>SOFTPRO</b>® simple 110kg + x1 Anti-shock                      Fixation à plafond ou à faux plafond</p> <p><b>110kg</b> por hoja   per panel   par panneaux</p>  <p>103x70mm    103x87mm    RODAMIENTO A BOLAS                      BALL BEARING                      ROULEMENT À BILLES</p> <p><b>SOFTPRO</b></p>	<b>S</b>	0 109 58 0 109 80	3 m 4 m	1 kit 1 jeu
	<p>Kit SV-T-PRO X110 con/sin vidrios fijos (12mm)                      x2 <b>SOFTPRO</b>® 110kg + x1 Anti-shock. Montaje a techo o falso techo                      SV-T-PRO X110 kit with/without fixed glass (12mm)                      x2 <b>SOFTPRO</b>® 110kg + x1 Anti-shock. Ceiling or false ceiling mounting                      Kit SV-T-PRO X110 avec/sans verre fixe (12mm)                      x2 <b>SOFTPRO</b>® 110kg + x1 Anti-shock. Fixation à plafond ou à faux plafond</p> <p><b>110kg</b> por hoja   per panel   par panneaux</p>  <p>103x70mm    103x87mm    RODAMIENTO A BOLAS                      BALL BEARING                      ROULEMENT À BILLES</p> <p><b>SOFTPRO</b></p>	<b>S</b>	0 109 82 0 109 84	3 m 4 m	1 kit 1 jeu



## Cerraduras Glass

Locks | Serrures

# CERRADURAS GLASS

BIBLIOTECA  
DE DESCARGAS



DOWNLOADS LIBRARY |  
BIBLIOTHÈQUE  
TÉLÉCHARGEMENTS

## — ES

SAHECO ofrece soluciones integrales para todos sus tipos de puerta, es por este motivo que dispone de diversos modelos de cerradura en aluminio anodizado y cromadas como solución de cerramiento para puertas correderas de vidrio; aptas para grosores de vidrio de 8-10-12mm.

Asimismo, también existe la posibilidad de instalación con cerrador en el caso de tratarse de hojas correderas opuestas. Sistemas sencillos y funcionales, adaptables a cualquier tipo de ambiente.

## — EN

SAHECO offers comprehensive solutions for all your door types, which is why it has different lock models available in anodised aluminum and chrome as a locking solution for sliding glass doors; suitable for glass with a thickness of 8-10-12 mm.

In addition, there is also the possibility of installing with a fastener in the case of opposing sliding panels. Simple and functional systems that are adaptable to any type of environment.

## — FR

SAHECO offre des solutions intégrales pour tous vos types de portes. Nous disposons ainsi de plusieurs modèles de serrures en aluminium anodisé et de modèles chromés pour la fermeture des portes coulissantes vitrées. Adaptées à des épaisseurs de verre de 8-10-12mm.

Il est également possible de prévoir une installation avec gâche dans le cas de panneaux coulissants opposés. Des systèmes simples et fonctionnels qui s'adaptent à n'importe quel espace.





### Características técnicas

Technical characteristics | Caractéristiques techniques

Especificaciones Specifications | Spécification



8-10-12 mm

Peso Weight | Poids

Según instalación | Depending on the installation | Selon installation

### Producto certificado

Certificaded product | Produit certifié



### Variantes de instalación

Installation possibilities | Variantes d'installation

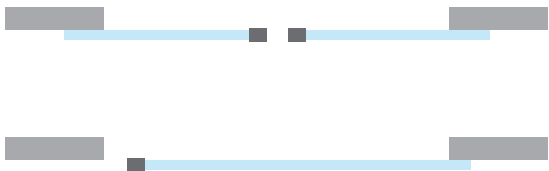

### Sección tipo

Cross-section | Section type (Cotas en mm | Dimensions in mm | Dimensions en mm)

Código | Code **00 66 60**

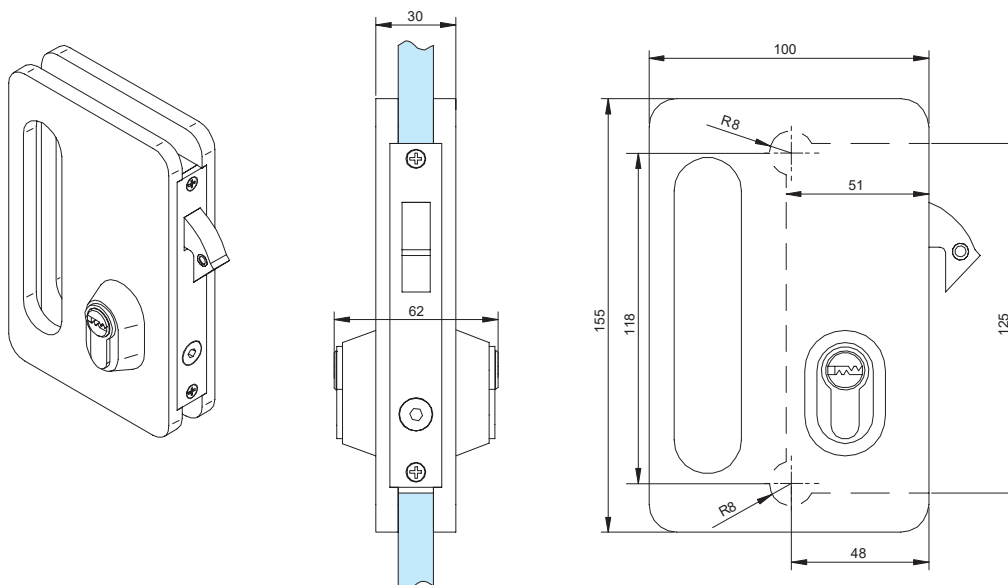



**Sección tipo**

Cros-section | Section type (Cotas en mm | Dimensions in mm | Dimensions en mm)

**MONTAJE A TECHO | CEILING MOUNT | FIXATION À PLAFOND**

Código | Code **00 66 61**

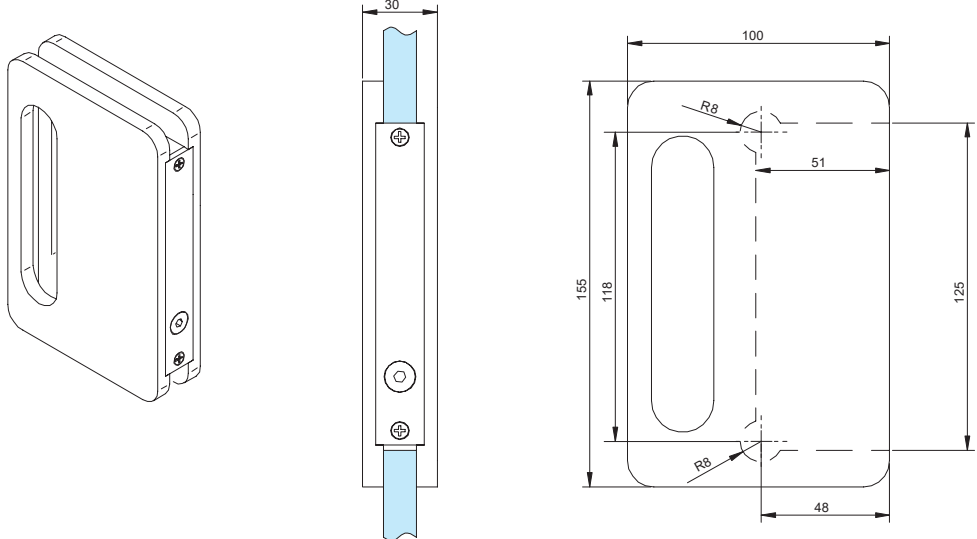

Código | Code **00 66 62**

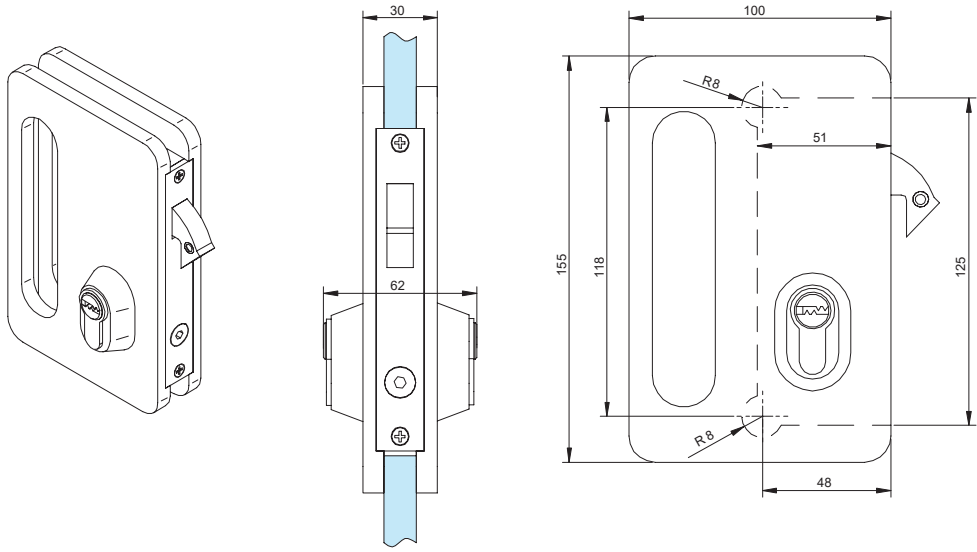

Código | Code **00 66 63**

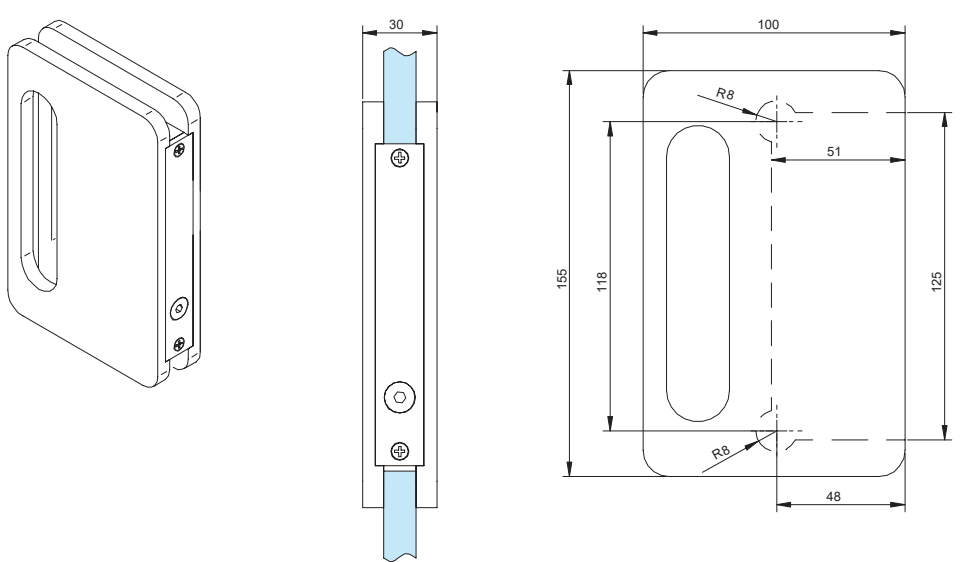

**Sección tipo**

Cross-section | Section type (Cotas en mm | Dimensions in mm | Dimensions en mm)

Código | Code **00 66 65**

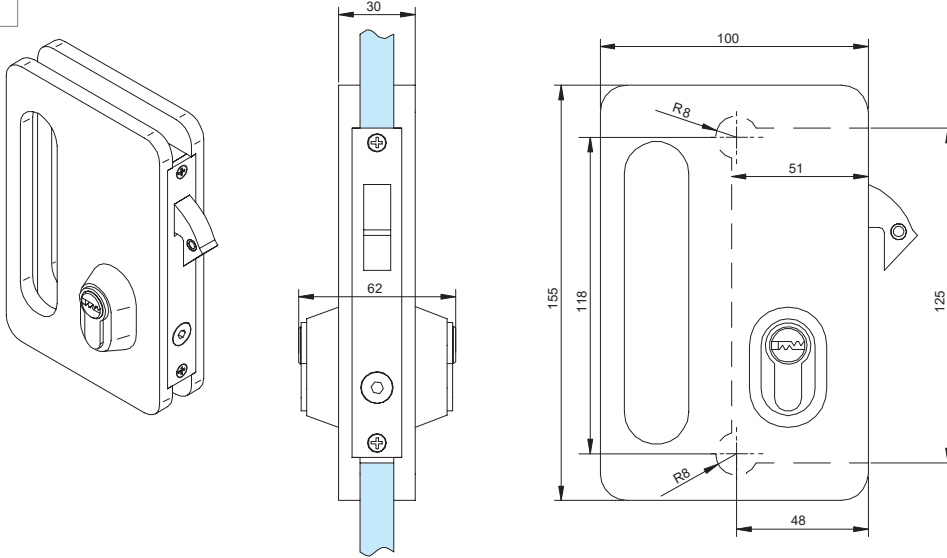

Código | Code **00 66 66**

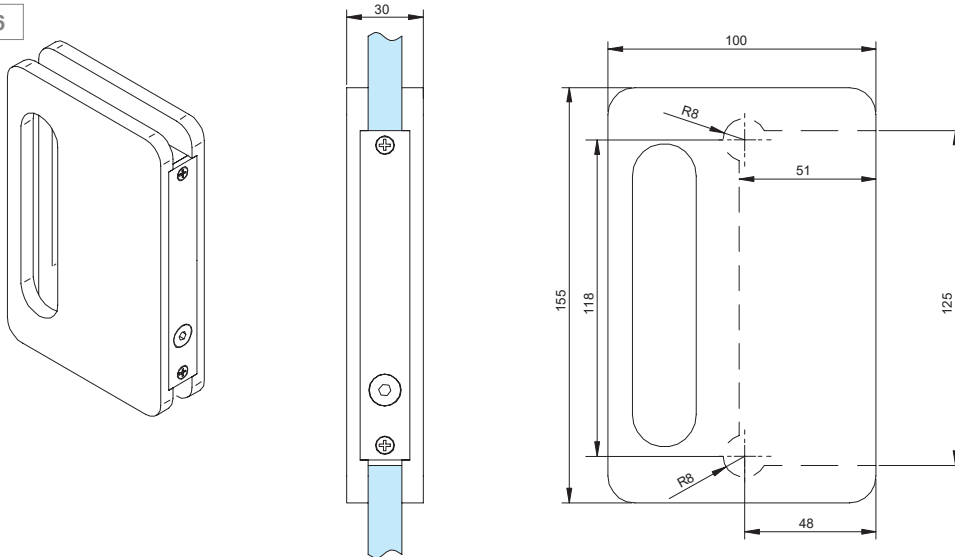

**Mecanización del vidrio** | Glass drilling | Usinage du verre

Código | Code **00 66 60 / 00 66 61 / 00 66 62 / 00 66 63 / 00 66 55 / 00 66 66**

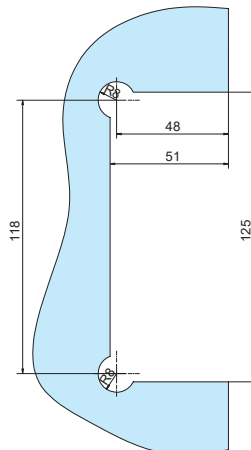



**Sección tipo**

Cros-section | Section type (Cotas en mm | Dimensions in mm | Dimensions en mm)

Código | Code 00 66 64 / 00 66 94

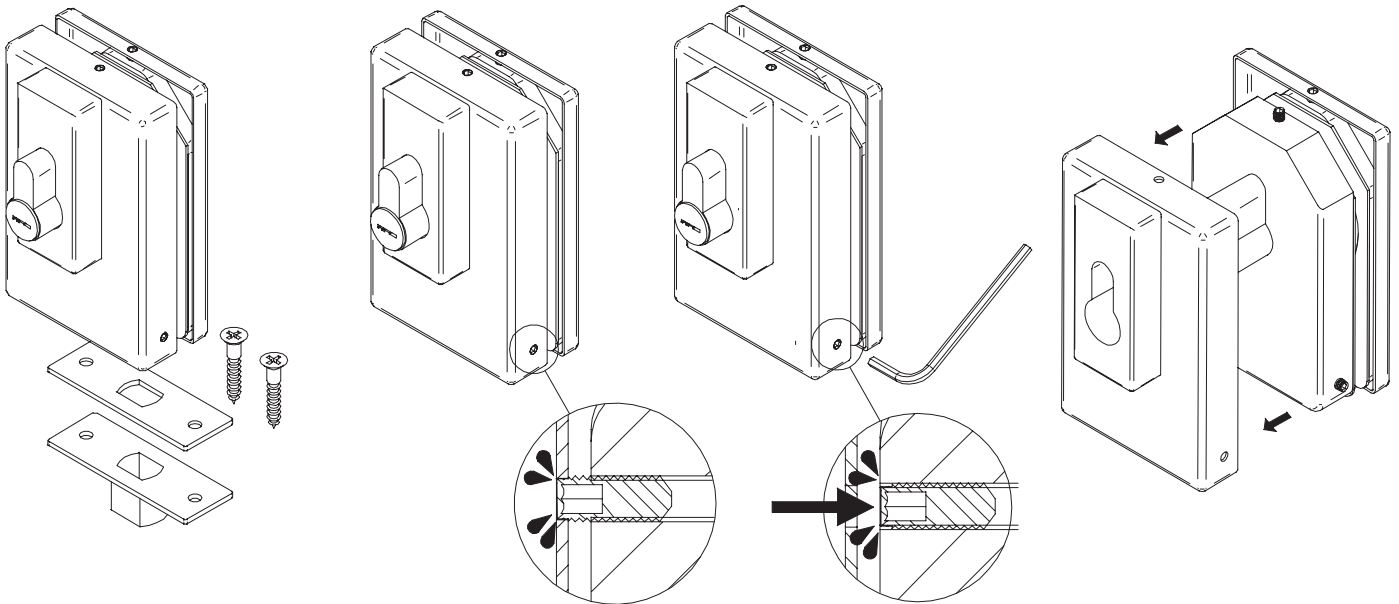

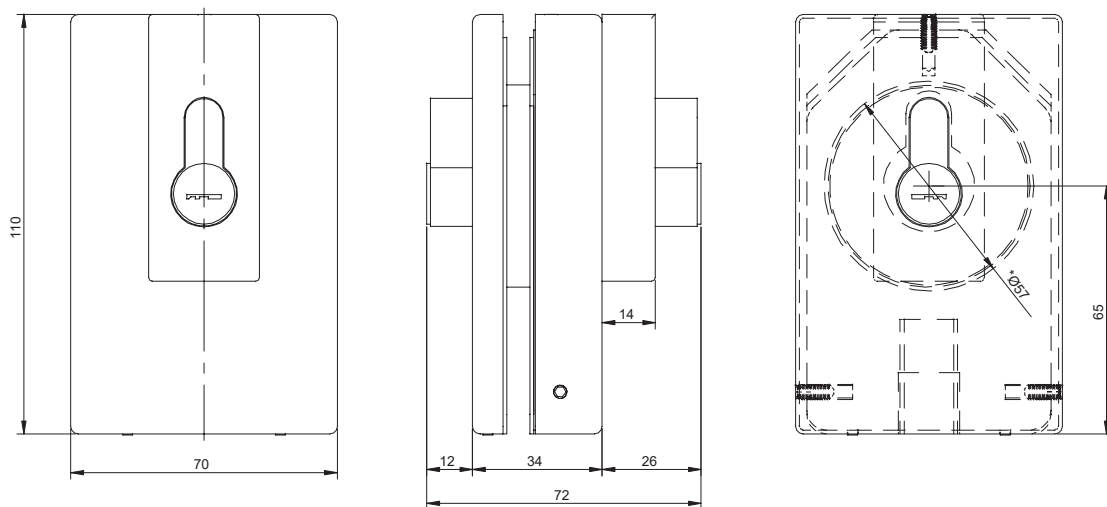

**Mecanizado del vidrio | Glass drilling | Usinage du verre**

Código | Code 00 66 64 / 00 66 94



**Componentes**

Components | Composants

ACCESORIOS   ACCESSORIES   ACCESSOIRES			Acabado	Cód.	8 - 10 - 12 mm	📦
	<p>Cerradura con gancho para puerta corredera de vidrio                      Glass sliding door lock with strike plate                      Serrure pour porte coulissante en verre avec gâchet</p>	<p>8 - 10 - 12 mm</p>	<p>1 pieza 1 pièce</p>	<b>S</b> 00 66 60 <sup>1</sup>		
				<b>PC</b> 00 66 62 <sup>1</sup>		
				<b>304</b> 00 66 65 <sup>1</sup>		
				<b>BL</b> 00 66 93 <sup>1</sup>		
	<p>Cerradura para puerta corredera de vidrio                      Glass sliding door lock                      Serrure pour porte coulissante en verre</p>	<p>8 - 10 - 12 mm</p>	<p>1 pieza 1 pièce</p>	<b>S</b> 00 66 61		
				<b>PC</b> 00 66 63		
				<b>304</b> 00 66 66		
				<b>BL</b> 00 66 95		
	<p>Cerradura de suelo para puerta corredera de vidrio                      Floor lock for glass sliding door                      Serrure basse pour porte coulissante en verre</p>	<p>8 - 10 - 12 mm</p>	<p>1 pieza 1 pièce</p>	<b>304</b> 00 66 64		
				<b>SSS</b> 00 66 94		

<sup>1</sup> No se pueden amaestrar las llaves | <sup>1</sup> Master keys not available | <sup>1</sup> Crochetage de clés n'est pas disponible

**PC**

**Aluminio pulido cromado**  
 Chrome polished aluminium  
 Aluminium polie chromé  
 Brillante | Shiny | Brillant

**304**

**Inox**  
 Stainless Steel

**BL**

**Aluminio lacado negro mate**  
 Matt black lacquered aluminium  
 Aluminium anodisé laqué noir mat

**S**

**Aluminio anodizado plata mate**  
 Satin anodized aluminium  
 Aluminium anodisé argent

**SSS**

**Inox brillante**  
 Shiny Stainless Steel  
 Inox brillant



## **Tiradores Glass**

Handles | Poignées

# TIRADORES GLASS

BIBLIOTECA  
DE DESCARGAS



DOWNLOADS LIBRARY |  
BIBLIOTHÈQUE  
TÉLÉCHARGEMENTS

## — ES

El complemento perfecto para puertas correderas de vidrio en distintos modelos y aptos para grosores de vidrio de 8-10-12mm:

Previo mecanizado de vidrio

En acabados de latón cromado brillo y mate e inoxidable, estos tiradores destacan por su rosca; de modo que lo hacen un producto de fácil instalación.

Sin previo mecanizado de vidrio

Tiradores adhesivos inoxidables en distintos diseños para combinar según las necesidades de cada instalación. Funcionalidad y perfecto acabado gracias a su sencilla colocación en la hoja de vidrio.

## — EN

The perfect complement for different models of sliding glass doors suitable for 8-10-12mm thick glass:

With pre-machined glass

In chromed brass with gloss and matt finishes and stainless steel, the special feature of these handles is that they are threaded and thus the product is easy to install.

Without pre-machined glass

Stainless steel adhesive handles in different designs that can be combined according to the requirements of each installation. Functionality and a perfect finish, thanks to their straightforward positioning on the glass panel.

## — FR

Ce parfait accessoire pour portes coulissantes vitrées est disponible en différentes versions et pour des verres de 8-10-12mm d'épaisseur:

Avec usinage préalable du verre

Finies en laiton chromé brillant et mat et en acier inoxydable, ces poignées sont dotées d'un filetage qui en facilite l'installation.

Sans usinage préalable du verre

Poignées adhésives inoxydables en différentes versions à combiner selon les besoins de chaque installation. Allient fonctionnalité et finition parfaite grâce à leur simplicité de pose sur le battant en verre.





### Características técnicas

Technical characteristics | Caractéristiques techniques

### Especificaciones Specifications | Spécification

#### Cód.

00 66 80

00 66 85



8-12 mm



10-12 mm



55 mm



65 mm



50 mm



25,5 mm  
TUBO | TUBE

### Peso Weight | Poids

Según instalación | Depending on the installation | Selon installation

### Producto certificado

Certificated product | Produit certifié



### Variantes de instalación

Installation possibilities | Variantes d'installation



### Sección tipo

Cros-section | Section type (Cotas en mm | Dimensions in mm | Dimensions en mm)

Cód. 00 66 68 | 00 66 69 | 00 66 77

Cód. 00 66 70 | 00 66 71

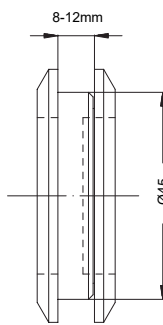
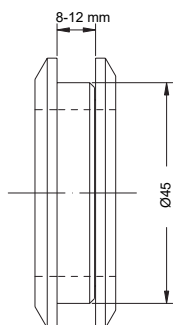
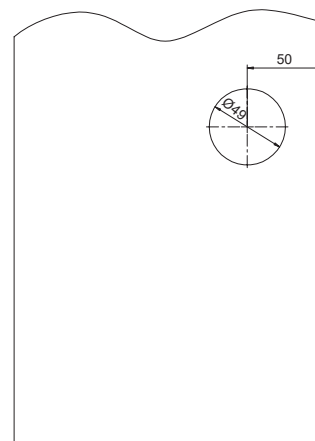
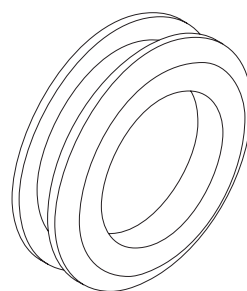
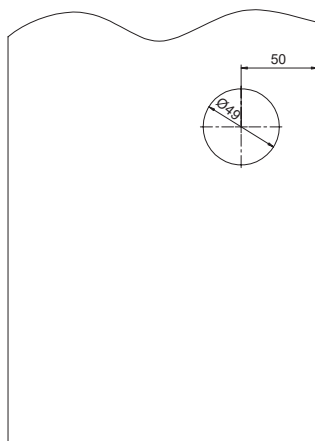
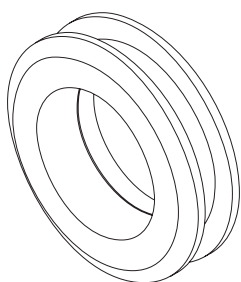



**Sección tipo**

Cross-section | Section type (Cotas en mm | Dimensions in mm | Dimensions en mm)

Cód. 00 66 72

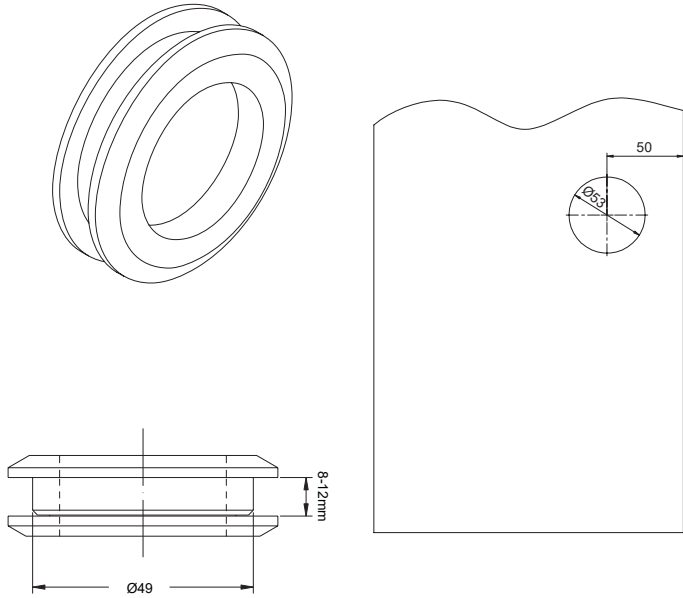

Cód. 00 66 86

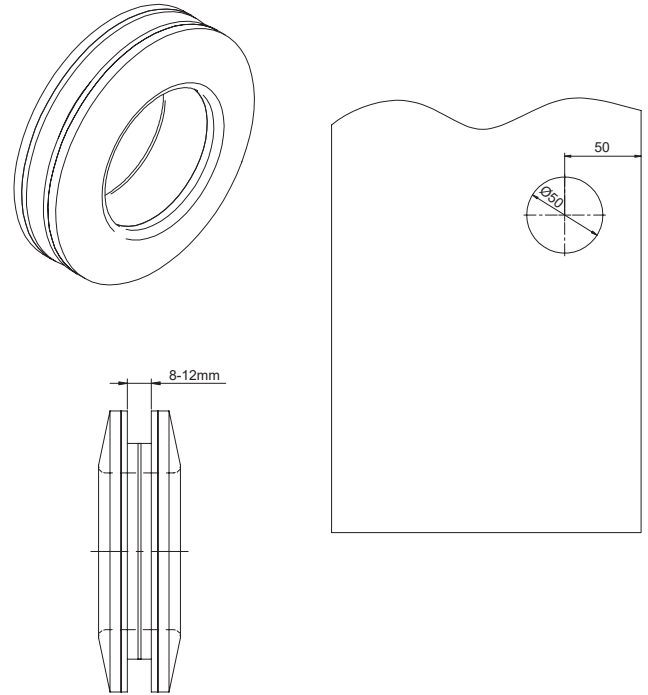

Cód. 00 66 87

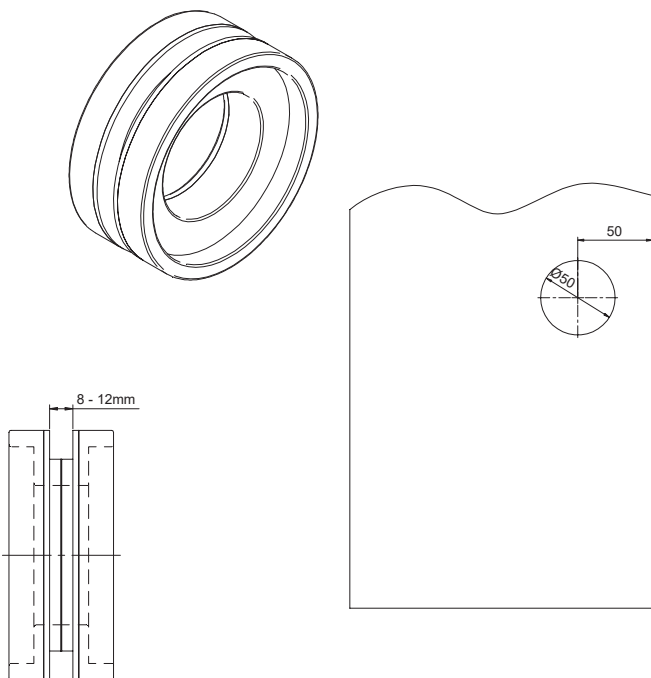

Cód. 00 66 88

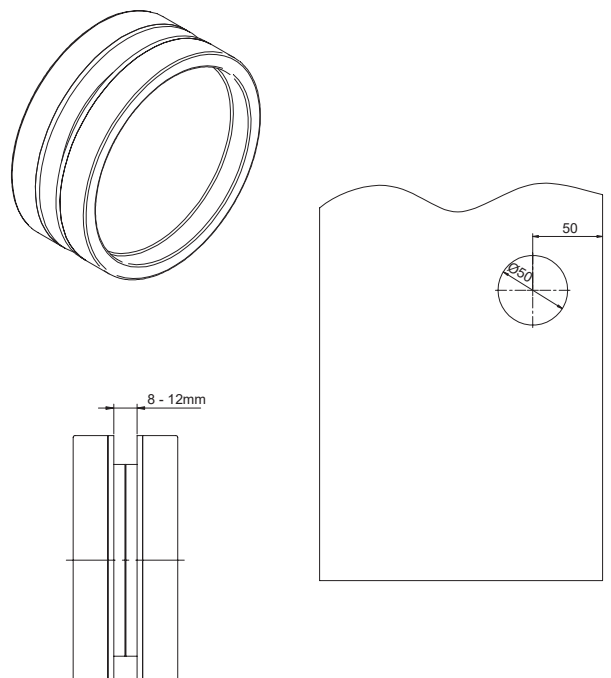

**Sección tipo**

Cross-section | Section type (Cotas en mm | Dimensions in mm | Dimensions en mm)

Cód. 00 66 89

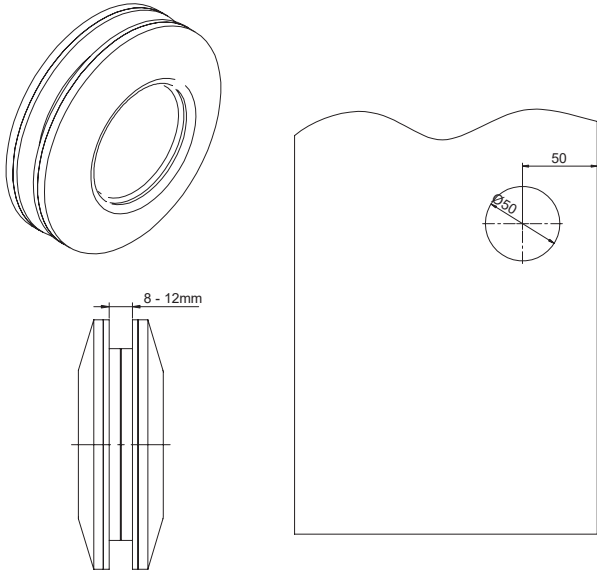

Cód. 00 66 90

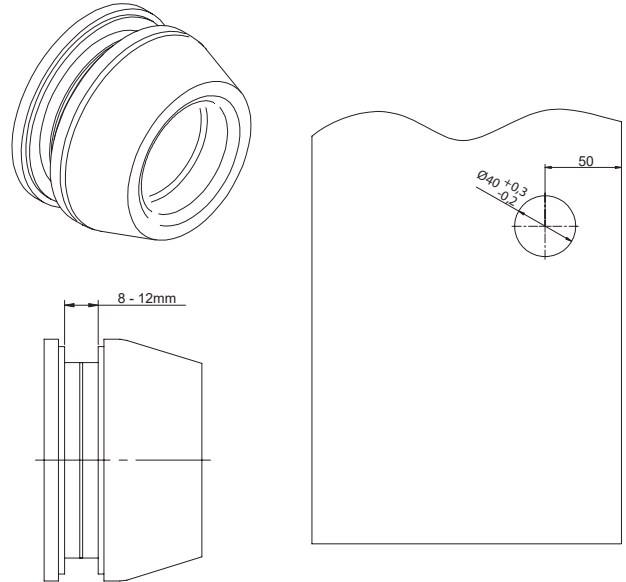

Cód. 00 66 91

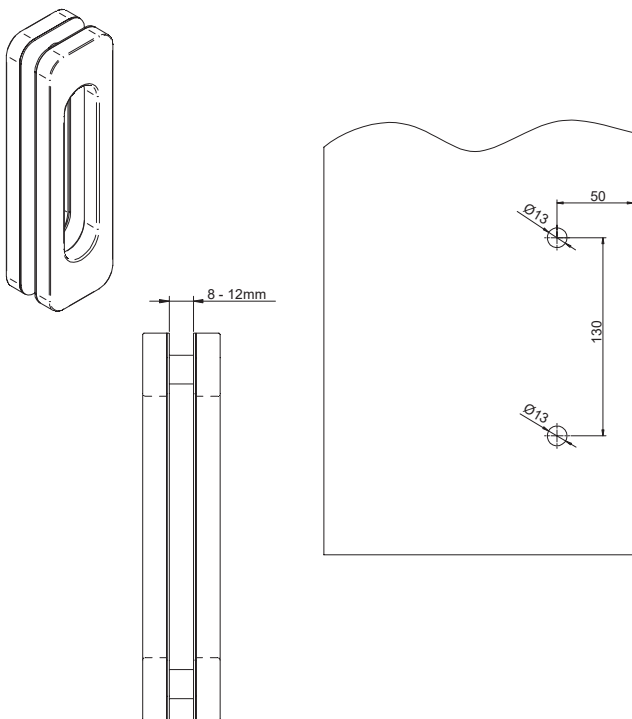

Cód. 00 66 80

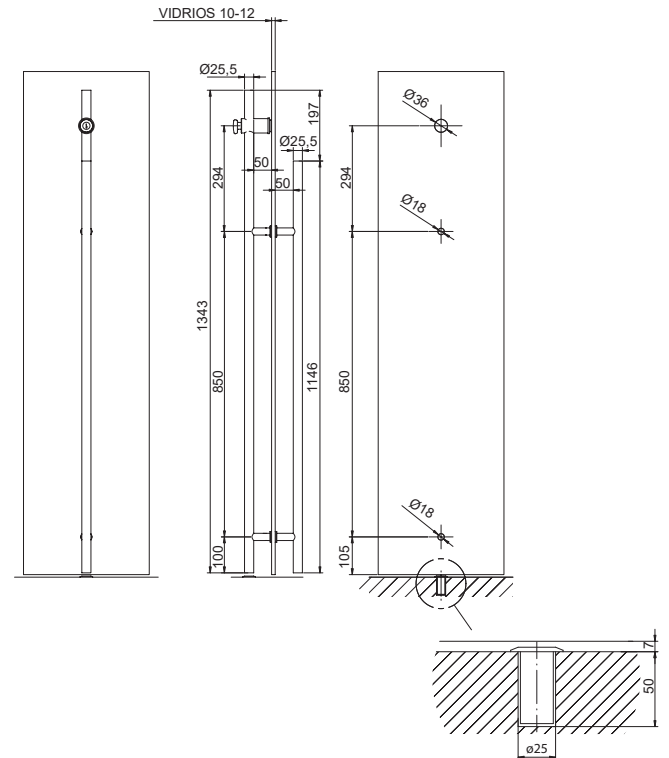

**Sección tipo**





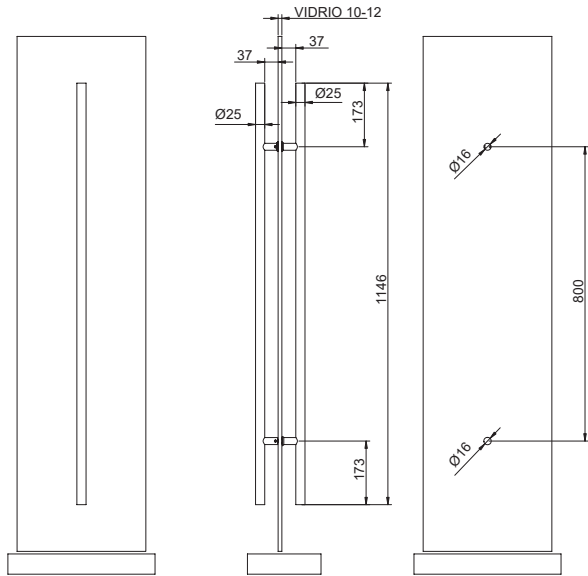



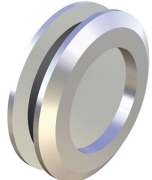

Cross-section | Section type (Cotas en mm | Dimensions in mm | Dimensions en mm)

Cód. 00 66 85

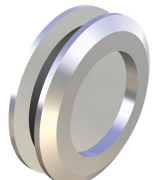

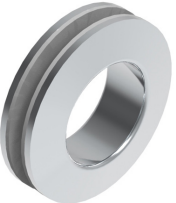
**Componentes**

Components | Composants

ACCESORIOS   ACCESSORIES   ACCESSOIRES		Acabado	Cód.	8-12 mm	📦
	Tirador redondo hueco Hollow round handle Poignée ronde creux  55mm	<b>S</b>	00 66 77	8-12 mm	1 pieza 1 piece 1 pièce
		<b>SS</b>	00 66 68		
		<b>PC</b>	00 66 69		
	Tirador redondo Round handle Poignée ronde  55mm	<b>S</b>	00 66 78	8-12 mm	1 pieza 1 piece 1 pièce
		<b>SS</b>	00 66 70		
		<b>PC</b>	00 66 71		
	Tirador redondo Round handle Poignée ronde  65mm	<b>304</b>	00 66 72	8-12 mm	1 pieza 1 piece 1 pièce
	Tirador redondo hueco Hollow round handle Poignée ronde creux  65mm	<b>S</b>	00 66 86	8-12 mm	1 pieza 1 piece 1 pièce
	Tirador redondo hueco Hollow round handle Poignée ronde creux  65mm	<b>S</b>	00 66 87	8-12 mm	1 pieza 1 piece 1 pièce

**S** Aluminio anodizado plata mate  
 Satin anodized aluminium  
 Aluminium anodisé argent

**SS** Aluminio anodizado plata  
 Satin anodized aluminium  
 Aluminium anodisé argent  
 \*Brillante | Shiny | Brillant













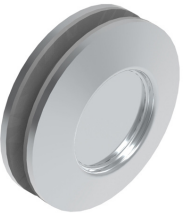

**PC** Aluminio pulido cromado  
 Chrome polished aluminium  
 Aluminium polie chromé  
 Brillante | Shiny | Brillant

**304** Inox  
 Stainless Steel



Componentes

Components | Composants

ACCESORIOS   ACCESSORIES   ACCESSOIRES		Acabado	Cód.		
	Tirador redondo Round handle Poignée ronde  65mm		00 66 88	8-12 mm	1 pieza 1 piece 1 pièce
	Tirador redondo Round handle Poignée ronde  65mm		00 66 89	8-12 mm	1 pieza 1 piece 1 pièce
	Tirador redondo Round handle Poignée ronde  50mm		00 66 90	8-12 mm	1 pieza 1 piece 1 pièce
	Tirador rectangular Rectangular handle Poignée rectangulaire  160 x 46 mm	 	00 66 91 00 66 92	8-12 mm	1 pieza 1 piece 1 pièce





 **Aluminio anodizado plata mate**  
 Satin anodized aluminium  
 Aluminium anodisé argent

 **Aluminio lacado negro mate**  
 Matt black lacquered aluminium  
 Aluminium anodisé laqué noir mat

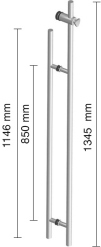

## Componentes

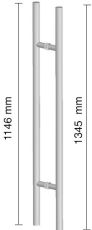
### Components | Composants

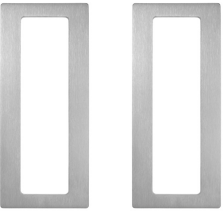
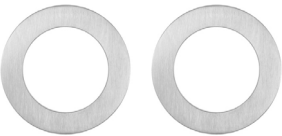
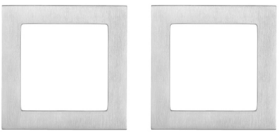
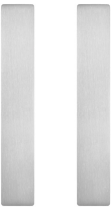
ACCESORIOS   ACCESSORIES   ACCESSOIRES		Acabado	Cód.		
	<p>Tirador cerradura Handle with lock Poignée avec serrure</p>  <p>25,5mm TUBO   TUBE</p>	<div style="border: 1px solid black; border-radius: 5px; padding: 2px; display: inline-block;">304</div> <div style="background-color: black; color: white; border-radius: 5px; padding: 2px; display: inline-block;">BL</div>	<p>00 66 80 00 66 96</p>	<p>10-12 mm</p>	<p>1 pieza 1 pièce 1 pièce</p>
	<p>Tirador Handle Poignée</p>  <p>25,5mm TUBO   TUBE</p>	<div style="border: 1px solid black; border-radius: 5px; padding: 2px; display: inline-block;">304</div>	<p>00 66 85</p>	<p>10-12 mm</p>	<p>1 pieza 1 pièce 1 pièce</p>
	<p>Tirador adhesivo rectangular Rectangular adhesive handle Poignée adhésive rectangulaire</p> <div style="border: 1px solid black; border-radius: 10px; padding: 2px; display: inline-block;">150 x 65 x 6 mm</div>	<div style="border: 1px solid black; border-radius: 5px; padding: 2px; display: inline-block;">304</div>	<p>00 66 73<sup>1</sup></p>		<p>1 juego 1 set 1 jeu</p>
	<p>Tirador adhesivo redondo Round adhesive handle Poignée adhésive ronde</p> <div style="border: 1px solid black; border-radius: 10px; padding: 2px; display: inline-block;">Ø 70 x 6 mm</div>	<div style="border: 1px solid black; border-radius: 5px; padding: 2px; display: inline-block;">304</div>	<p>00 66 74<sup>1</sup></p>		<p>1 juego 1 set 1 jeu</p>
	<p>Tirador adhesivo cuadrado Square adhesive handle Poignée adhésive carrée</p> <div style="border: 1px solid black; border-radius: 10px; padding: 2px; display: inline-block;">65 x 65 x 6 mm</div>	<div style="border: 1px solid black; border-radius: 5px; padding: 2px; display: inline-block;">304</div>	<p>00 66 75<sup>1</sup></p>		<p>1 juego 1 set 1 jeu</p>
	<p>Tirador adhesivo recto Straight adhesive handle Poignée adhésive rectiligne</p> <div style="border: 1px solid black; border-radius: 10px; padding: 2px; display: inline-block;">150 x 25 x 6 mm</div>	<div style="border: 1px solid black; border-radius: 5px; padding: 2px; display: inline-block;">304</div>	<p>00 66 76<sup>1</sup></p>		<p>1 juego 1 set 1 jeu</p>

<sup>1</sup> Los tiradores adhesivos no requieren mecanización del vidrio | <sup>1</sup> The handles do not require the glass to be drilled | <sup>1</sup> Les poignées adhésives n'exigent pas l'usinage préalable du verre



## **Parking Glass**

SV-P40

# PARKING GLASS

BIBLIOTECA  
DE DESCARGAS



DOWNLOADS LIBRARY |  
BIBLIOTHÈQUE  
TÉLÉCHARGEMENTS

## — ES

**SV-P40 ES UNO DE LOS CERRAMIENTOS MÓVILES MÁS PRÁCTICOS Y VERSÁTILES DE SAHECO.** ESPECIALMENTE PENSADO PARA ESPACIOS INTERIORES Y EXTERIORES DE USO DOMÉSTICO O COMERCIAL DE PESO LIGERO O MEDIO.

**1.**Diseñado para dividir espacios mediante hojas correderas apilables perpendicularmente al final de la guía, en su zona de estacionamiento (hasta en un ángulo de 90°). **2.**Hasta 40 kg./hoja y vidrios de 6 a 10 mm de grosor; con anchura y altura máxima de instalación de 11,2m y 2,8m respectivamente. **3.**Rodamiento a bolas que puede salir de la guía. **4.**Puede instalarse con o sin perfilera inferior ofreciendo así multiplicidad de soluciones: balconeras, terrazas, porches, etc. **5.**En ambos casos este sistema proporciona una buena estanqueidad de las hojas de vidrio. **6.**Roldandas inox anticorrosión para montaje en exteriores. **7.**Rápidamente maniobrable que permite abrir y cerrar espacios en muy poco tiempo.

## — ES

**SV-P40 IS ONE OF SAHECO'S MOST PRACTICAL AND VERSATILE MOBILE CLOSING SYSTEMS.** DESIGNED FOR INDOOR AND OUTDOOR AREAS, AND FOR LIGHTWEIGHT OR MEDIUM WEIGHT DOMESTIC OR COMMERCIAL USE.

**1.**It is designed to divide spaces using sliding panels that are stackable perpendicularly at the end of the guide, in their parking area (up to an angle of 90°). **2.**Up to 40 kg/ panel and 6 to 10 mm thick glass panes; with a maximum installation width and height of 11.2m and 2.8 m respectively. **3.**Ball-bearing rollers which can leave the guide. **4.**It can be installed with or without bottom guide channels, thus providing multiple solutions: balconies, terraces, porches, etc. **5.**In both cases, this system provides excellent sealing of the glass panels. **6.**Anticorrosion stainless steel roller for outdoor fitting. **7.**A fast manoeuvrable system that enables areas to be opened up and closed off in a very short time.

## — ES

**SV-P40 COMPTE PARI MI LES HUISSERIES MOBILES LES PLUS PRATIQUES ET LES PLUS POLYVALENTES DE SAHECO.** SPÉCIALEMENT CONÇUES POUR LES ESPACES INTÉRIEURS ET EXTÉRIEURS À USAGE RÉSIDENTIEL OU COMMERCIAL DE POIDS LÉGER OU MOYEN.

**1.**Conçu pour diviser les espaces à l'aide de battants coulissants qui s'empilent de façon perpendiculaire en bout de rail, dans une zone de stationnement (jusqu'à un angle de 90°). **2.**Jusqu'à 40 kg/battant et verres de 6 à 10 mm d'épaisseur; largeur et hauteur maximales d'installation de 11,2 m et 2,8 m respectivement. **3.**Roulement à billes qui peut sortir du rail. **4.**Peut s'installer avec ou sans huisserie inférieure, ce qui offre ainsi un vaste éventail de solutions: balcons, terrasses, porches, etc. **5.**Dans les deux cas ce système offre une bonne étanchéité des battants en verre. **6.**Montures inox anticorrosion pour le montage en extérieur. **7.**Système rapidement manoeuvrable qui permet d'ouvrir et de clore les espaces en très peu de temps.





### Características técnicas

Technical characteristics | Caractéristiques techniques

### Perfilería Profiles | Profils



47x62mm



47x48mm

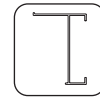

38x51mm

### Especificaciones Specifications | Spécification



6-8-10 mm



700 mm

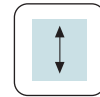

2800 mm



MÁX. 8 HOJAS  
| PANELS  
| PANNEAUX

### Peso Weight | Poids

40 kg

88 lb

### Producto certificado

Certificated product | Produit certifié





### Variantes de instalación

Installation possibilities | Variantes d'installation

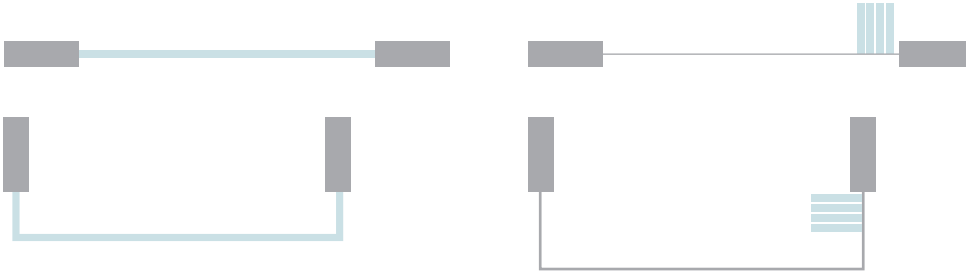

### Sección tipo

Cross-section | Section type (Cotas en mm | Dimensions in mm | Dimensions en mm)

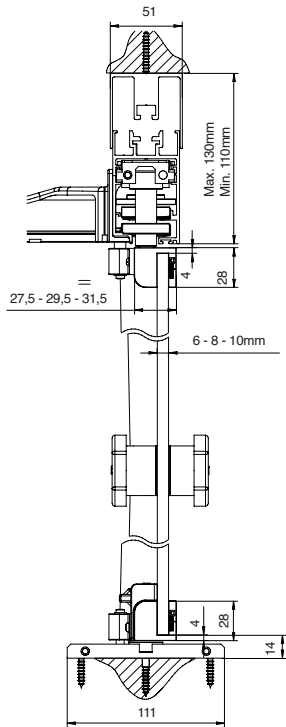

H-144

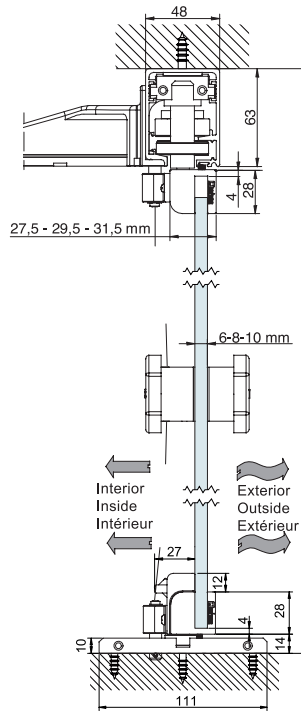







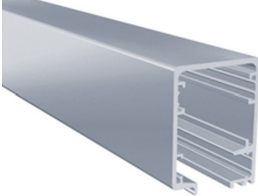

A = H - 53      F = H - 77

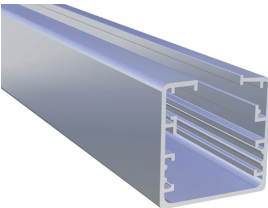

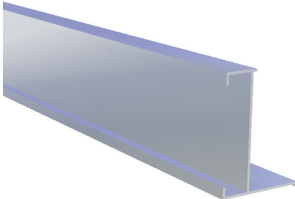
## Componentes

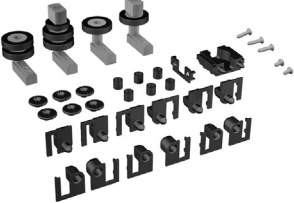
Components | Composants

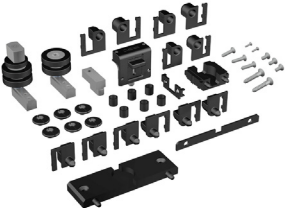
PERFILERÍA   PROFILES   PROFILS		Acabado	Cód.		
 <p>Perfil superior Top track Rail supérieur</p>  <p>47x62mm</p>	S	00 96 23	2 m	2 perfiles 2 profiles 2 profils	
		00 96 33	3 m		
		00 96 63	6 m		
	MF	00 98 22	2 m		
		00 98 32	3 m		
		00 98 62	6 m		
	WL	00 96 22	2 m		
		00 96 32	3 m		
		00 96 62	6 m		
 <p>Perfil Inferior Bottom track Rail inférieur</p>  <p>47x48mm</p>	S	00 96 21	2 m	2 perfiles 2 profiles 2 profils	
		00 96 31	3 m		
		00 96 61	6 m		
	MF	00 98 20	2 m		
		00 98 30	3 m		
		00 98 60	6 m		
	WL	00 96 20	2 m		
		00 96 30	3 m		
		00 96 60	6 m		
 <p>Perfil Lateral Side track Rail latéral</p> 	S	00 96 29	2 m	2 perfiles 2 profiles 2 profils	
		00 96 39	3 m		
		00 96 69	6 m		
	MF	00 98 28	2 m		
		00 98 38	3 m		
		00 98 68	6 m		
	WL	00 96 28	2 m		
		00 96 38	3 m		
		00 96 68	6 m		
JUEGOS   SETS   JEUX		Acabado	Cód.		
 <p>Juego de accesorios <b>SV-P40</b> (Hoja batiente) SV-P40 Fitting set (Swing door) Garniture SV-P40 (Porte pivotante)</p> <p><b>40kg</b> Con perfil inferior I With bottom track I Avec rail inférieur</p>		00 96 01		1 juego 1 set 1 jeu	
	 <p>Juego de accesorios <b>SV-P40</b> (Hojas centrales) SV-P40 Fitting set (Central doors) Garniture SV-P40 (Portes centraux)</p> <p><b>40kg</b> Con perfil inferior I With bottom track I Avec rail inférieur</p>		00 96 02		1 juego 1 set 1 jeu
 <p>Juego de accesorios <b>SV-P40</b> (Hoja batiente) SV-P40 Fitting set (Swing door) Garniture SV-P40 (Porte pivotante)</p> <p><b>40kg</b> Sin perfil inferior I Without bottom track I Sans rail inférieur</p>			00 96 11		1 juego 1 set 1 jeu
	 <p>Juego de accesorios <b>SV-P40</b> (Hojas centrales) SV-P40 Fitting set (Central doors) Garniture SV-P40 (Portes centraux)</p> <p><b>40kg</b> Sin perfil inferior I Without bottom track I Sans rail inférieur</p>		00 96 12		1 juego 1 set 1 jeu

**S** Aluminio anodizado plata mate  
Satin anodized aluminium  
Aluminium anodisé argent







**MF** Aluminio natural  
Mill finish aluminium  
Aluminium brut

**WL** Aluminio lacado blanco  
White lacquered aluminium  
Aluminium anodisé laqué blanc

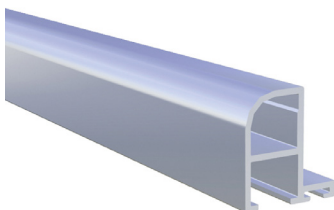

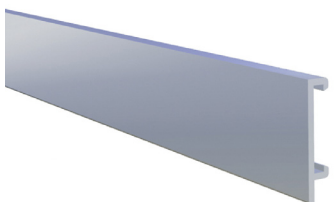
## Componentes

### Components | Composants

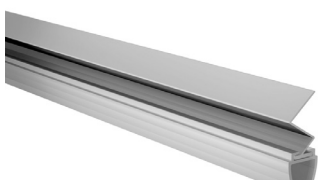
ACCESORIOS   ACCESSORIES   ACCESSOIRES		Acabado	Cód.	Longitud	Quantidad
 <p>Pinza para vidrio Glass clamp Pince pour</p>  <p>25x28mm</p>	S	00 96 25	2 m	2 perfiles 2 profiles 2 profils	
		00 96 35	3 m		
		00 96 65	6 m		
	MF	00 98 24	2 m		
		00 98 34	3 m		
		00 98 64	6 m		
	WL	00 96 24	2 m		
		00 96 34	3 m		
		00 96 64	6 m		
 <p>Tapeta para pinza Pelmet cover for clamp Cache-pince</p>  <p>5x28mm</p>	S	00 96 27	2 m	2 perfiles 2 profiles 2 profils	
		00 96 37	3 m		
		00 96 67	6 m		
	MF	00 98 26	2 m		
		00 98 36	3 m		
		00 98 66	6 m		
	WL	00 96 26	2 m		
		00 96 36	3 m		
		00 96 66	6 m		
 <p>Perfil plástico salvacantos lateral Plastic edge-protecting side track Rail plastique latéral protecteur de chants</p>		00 86 37 (6 mm)	3 m	1 perfil 1 profile 1 profil	
		00 86 38 (8 mm)			
		00 86 39 (10 mm)			
 <p>Perfil plástico salvacantos central Plastic edge-protecting central track Rail plastique central protecteur de chants</p>		00 86 34 (6 mm)	3 m	1 perfil 1 profile 1 profil	
		00 86 35 (8 mm)			
		00 86 36 (10 mm)			
 <p>Perfil plástico salvacantos central rígido Rigid plastic edge-protecting central track Rail plastique central protecteur rigide</p>		00 86 40 (6 mm)	3 m	1 perfil 1 profile 1 profil	
		00 86 41 (8 mm)			
		00 86 42 (10 mm)			
 <p>Perfil plástico salvacantos lateral flexible Flexible plastic edge-protecting side track Rail plastique protecteur de chant latéral flexible</p>		00 86 43 (6 mm)	3 m	1 perfil 1 profile 1 profil	
		00 86 44 (8 mm)			
		00 86 45 (10 mm)			



Aluminio anodizado plata mate  
Satin anodized aluminium  
Aluminium anodisé argent



Aluminio natural  
Mill finish aluminium  
Aluminium brut



Aluminio lacado blanco  
White lacquered aluminium  
Aluminium anodisé laqué blanc



Componentes

Components | Composants

ACCESORIOS   ACCESSORIES   ACCESSOIRES		Acabado	Cód.		
	<p>Pomo <b>SV-P40</b> SV-P40 knob Pommeau SV-P40</p>		00 96 99		1 juego 1 set 1 jeux
	<p>Burlete para perfil superior Top track brush draught excluder Bourelet pour rail supérieur</p>		00 86 10	1 m	
	<p>Burlete para perfil inferior <b>SV-P40</b> con perfil inferior SV-P40. Bottom track brush with bottom track Bourelet pour track inférieur SV-P40 avec track inférieur</p>		00 86 11 (16mm)	1 m	
	<p>Burlete para <b>SV-P40</b> sin perfil inferior SV-P40 Brush without bottom track Bourelet inférieur pour SV-P40 sans rail inférieur</p>		00 86 12 (19mm)	1 m	
	<p>Matriz para mecanizados Matrix for machining aluminium Matrice pour pièces usinées en aluminium</p>		00 86 90		1 pieza 1 piece 1 pièce
	<p>Roldana superior <b>SV-P40</b> central SV-P40 top centre roller Galet supérieure SV-P40 central</p>	304	00 96 70		50 piezas 50 pieces 50 pièces
	<p>Roldana superior Interior <b>SV-P40</b> SV-P40 inside top roller Galet supérieure intérieur SV-P40</p>	304	00 96 72		50 piezas 50 pieces 50 pièces



## Componentes

### Components | Composants

ACCESORIOS   ACCESSORIES   ACCESSOIRES		Acabado	Cód.		
	Roldana superior <b>SV-P40</b> batiente SV-P40 Swing top roller Galet supérieur SV-P40 pivotante	304	00 96 74		50 piezas 50 pieces 50 pièces
	Roldana inferior <b>SV-P40</b> central SV-P40 Central bottom roller Galet inférieur SV-P40 central	304	00 96 71		50 piezas 50 pieces 50 pièces
	Roldana inferior Interior <b>SV-P40</b> SV-P40 Inside bottom roller Galet inférieur SV-P40 intérieur	304	00 96 73		50 piezas 50 pieces 50 pièces
	Roldana inferior <b>SV-P40</b> batiente SV-P40 Swing bottom roller Galet inférieur SV-P40 pivotante	304	00 96 75		50 piezas 50 pieces 50 pièces
	Roldana inferior <b>SV-P40</b> batiente SV-P40 Swing bottom roller Galet inférieur SV-P40 pivotante	304	00 96 82		50 piezas 50 pieces 50 pièces
	Guiador entrada Roldana Derecha <b>SV-P41</b> SV-P41 right-hand roller entry guide Guide d'entrée galet droite SV-P41		00 96 94		25 piezas 25 pieces 25 pièces
	Guiador entrada Roldana Izquierda <b>SV-P40</b> SV-P40 left-hand roller entry guide Guide d'entrée galet gauche SV-P40		00 96 87		25 piezas 25 pieces 25 pièces

304

Inox  
Stainless  
Steel



## Componentes

### Components | Composants

ACCESORIOS   ACCESSORIES   ACCESSOIRES		Acabado	Cód.		
	<p>Soporte fijacion pinza cristal Glass clamp securing bracket Support de fixation - pince en verre</p>		00 96 76		100 piezas 100 pieces 100 pièces
	<p>Soporte pivote puertas <b>SV-P40</b> SV-P40 doors pivot bracket Support-pivot portes SV-P40</p>		00 96 78		25 piezas 25 pieces 25 pièces
	<p>Soporte pivotante inf. <b>SV-P40</b> SV-P40 bottom pivot bracket Support pivotant inf. SV-P40</p>		00 96 81		25 piezas 25 pieces 25 pièces
	<p>Tope soporte rotación batientes Hinged rotation bracket end-stop Butée de support rotation portes battantes</p>		00 96 44		100 piezas 100 pieces 100 pièces
	<p>Centrador pivote puerta Door pivot centring device Centreur-pivot porte</p>		00 96 47		25 piezas 25 pieces 25 pièces
	<p>Entrada pivote puerta sin perfil inferior <b>SV-P40</b> SV-P40 door pivot entry without bottom track Entrée-pivot porte sans rail inférieur SV-P40</p>		00 96 46		25 piezas 25 pieces 25 pièces
	<p>Pivote puerta sin perfil inferior <b>SV-P40</b> SV-P40 door pivot without bottom track Pivot de porte sans rail inférieur SV-P40</p>		00 96 45		25 piezas 25 pieces 25 pièces



## Componentes

Components | composants

ACCESORIOS   ACCESSORIES   ACCESSOIRES		Acabado	Cód.		
	Pletina retención soporte pivote <b>SV-P40</b> SV-P40 pivot bracket retaining plate Platine de retenue support-pivot SV-P40		00 96 48		100 piezas 100 pieces 100 pièces
	Grueso pivote <b>SV-P40</b> SV-P40 pivot strip Gros du pivot SV-P40		00 96 93		50 piezas 50 pieces 50 pièces
	Grueso pivote superior <b>SV-P40</b> SV-P40 top pivot strip Gros du pivot suo SV-P40		00 96 91		100 piezas 100 pieces 100 pièces
	Fijador superior pomo inox cerradura <b>SV-P40</b> batiente Hinged SV-P40 lock stainless steel knob top securing bracket Fixation supérieure pommeau inox huisserie SV-P40 porte pivotante		00 96 41		25 piezas 25 pieces 25 pièces
	Fijador inferior pomo inox cerradura <b>SV-P40</b> batiente Hinged SV-P40 lock stainless steel knob bottom securing bracket Fixation inférieure pommeau inox huisserie SV-P40 porte pivotante		00 96 40		25 piezas 25 pieces 25 pièces
	Cerradero <b>SV-P40</b> central Central SV-P40 strike plate Gâche SV-P40 centrale		00 96 84		25 piezas 25 pieces 25 pièces
	Casquillo adaptador vidrio 10mm <b>SV-P40</b> SV-P40 10mm glass adapter bush Douille adaptatrice verre 10 mm SV-P40		00 96 89		100 piezas 100 pieces 100 pièces



## Componentes

Components | Composants

ACCESORIOS   ACCESSORIES   ACCESSOIRES		Acabado	Cód.		
	<p>Tapon vierteaguas <b>SV-P40</b> SV-P40 gutter plug Bouchon gouttière SV-P40</p>		00 96 92		50 piezas 50 pieces 50 pièces
	<p>Embellecedor entrada roldanas inferior <b>SV-P40</b> SV-P40 bottom roller entry trim Enjoliveur d'entrée montures inférieures SV-P40</p>		00 96 43		25 piezas 25 pieces 25 pièces
	<p>Tapa embellecedor entrada roldanas inferior <b>SV-P40</b> SV-P40 bottom roller entry trim cover Cache enjoliveur d'entrée des montures inférieures SV-P40</p>		00 96 42		25 piezas 25 pieces 25 pièces
	<p>Tapeta ciega pinza vidrio 6mm izquierda + derecha <b>SV-P40</b> SV-P40 left + right-hand 6mm glass clamp blind cover Obturateur de pince en verre 6 mm gauche + droite SV-P40</p>		00 96 95		100 piezas 100 pieces 100 pièces
	<p>Tapeta ciega pinza vidrio 8mm izquierda + derecha <b>SV-P41</b> SV-P41 left + right-hand 8mm glass clamp blind cover Obturateur de pince en verre 8 mm gauche + droite SV-P41</p>		00 96 96		100 piezas 100 pieces 100 pièces
	<p>Tapeta ciega pinza vidrio 10mm izquierda + derecha <b>SV-P42</b> SV-P42 left + right-hand 10mm glass clamp blind cover Obturateur de pince en verre 8 mm gauche + droite SV-P42</p>		00 96 97		100 piezas 100 pieces 100 pièces



## Componentes

### Components | Composants

ACCESORIOS   ACCESSORIES   ACCESSOIRES		Acabado	Cód.		
	<p>Tapeta macho/hembra pinza vidrio 6mm derecha. <b>SV-P40</b>                      SV-P40 right-hand 6mm glass clamp male/female cover                      Cache mâle/femelle de pince en verre 6 mm droite SV-P40</p>		00 96 16		100 piezas 100 pieces 100 pièces
	<p>Tapeta macho/hembra pinza vidrio 10mm derecha. <b>SV-P40</b>                      SV-P40 right-hand 10mm glass clamp male/female cover                      Cache mâle/femelle de pince en verre 10 mm droite SV-P40</p>		00 96 14		100 piezas 100 pieces 100 pièces
	<p>Tapeta macho/hembra pinza vidrio 8mm derecha. <b>SV-P40</b>                      SV-P40 right-hand 8mm glass clamp male/female cover                      Cache mâle/femelle de pince en verre 8 mm droite SV-P40</p>		00 96 15		100 piezas 100 pieces 100 pièces
	<p>Tapeta macho/hembra pinza vidrio 6mm izquierda. <b>SV-P40</b>                      SV-P40 left-hand 6mm glass clamp male/female cover                      Cache mâle/femelle de pince en verre 6 mm gauche SV-P40</p>		00 96 19		100 piezas 100 pieces 100 pièces
	<p>Tapeta macho/hembra pinza vidrio 8mm izquierda. <b>SV-P40</b>                      SV-P40 left-hand 8mm glass clamp male/female cover                      Cache mâle/femelle de pince en verre 8 mm gauche SV-P40</p>		00 96 18		100 piezas 100 pieces 100 pièces
	<p>Tapeta macho/hembra pinza vidrio 10mm izquierda. <b>SV-P40</b>                      SV-P40 left-hand 10mm glass clamp male/female cover                      Cache mâle/femelle de pince en verre 10mm gauche SV-P40</p>		00 96 17		100 piezas 100 pieces 100 pièces



## Parking Glass

SV-P150

# PARKING GLASS

BIBLIOTECA  
DE DESCARGAS



DOWNLOADS LIBRARY |  
BIBLIOTHÈQUE  
TÉLÉCHARGEMENTS

— ES

**SV-P150 SIGNIFICA FLEXIBILIDAD. UNA SOLUCIÓN IDEAL PARA LA CREACIÓN DE AMBIENTES DISTINTOS EN LUGARES PRÓXIMOS ENTRE SÍ DE USO COMERCIAL DE PESO MEDIO.**

**1.** Creación orientada a crear espacios para múltiples usos de hojas correderas de hasta 150 kg. **2.** Con anchura de la instalación ilimitada. **3.** Roldanas con 8 rodamientos a bolas de alta precisión y suavidad en el deslizamiento, además de regulación vertical. **4.** Instalación sin perfil inferior, de modo que no deja lugar a barreras arquitectónicas; asimismo, dispone de pivotes de seguridad para fijar las hojas al suelo.

La peculiaridad de este modelo es la zona de estacionamiento de las hojas, conocida como "parking"; la cual es muy reducida y permite estacionar los paneles donde se desee, perpendicularmente y paralelamente a la instalación.

— ES

**THE SV-P150 MEANS FLEXIBILITY. IT IS AN IDEAL SOLUTION FOR CREATING DIFFERENT ENVIRONMENTS IN AREAS THAT ARE CLOSE TOGETHER. FOR MEDIUM WEIGHT COMMERCIAL USE.**

**1.** A creation designed to create spaces for multiple uses of sliding panels of up to 150 kg. **2.** With an unlimited installation width. **3.** High precision rollers with 8 ball bearings for a smooth sliding action, as well as vertical adjustment. **4.** The installation has no bottom guide channel, thereby avoiding any architectural difficulties. It also has safety pivots to attach the panels to the floor.

The particular feature of this model is the panel parking area, which is very small, and allows the panels to be parked where desired, perpendicularly and parallel to the installation.

— ES

**SV-P150 EST SYNONYME DE FLEXIBILITÉ. UNE SOLUTION IDÉALE POUR L'AMÉNAGEMENT D'ESPACES DIFFÉRENCIÉS DANS DES LOCAUX À USAGE COMMERCIAL À PROXIMITÉ LES UNS DES AUTRES ET DE POIDS MOYEN.**

**1.** Gamme axée sur la création d'espaces polyvalents à battants coulissants de jusqu'à 150 kg. **2.** Largeur de l'installation illimitée. **3.** Montures 8 roulements à billes haute précision tout en douceur dans le glissement, plus réglage vertical. **4.** Installation sans profil inférieur qui évite les barrières architecturales. Dispose également de pivots de sécurité pour fixer les battants au sol.

Ce modèle se distingue par sa zone de stationnement des battants, appelée « parking ». Très réduite, cette zone permet de stationner les panneaux là où on le désire, perpendiculairement et parallèlement à l'installation.





### Características técnicas

Technical characteristics | Caractéristiques techniques

### Perfilería Profiles | Profils



98x73 mm

### Especificaciones Specifications | Spécification



10-12 mm



MÍN.600 mm



MÁX.1200 mm

### Peso Weight | Poids

150 kg

331 lb

### Producto certificado

Certificaded product | Produit certifié





### Variantes de instalación

Installation possibilities | Variantes d'installation

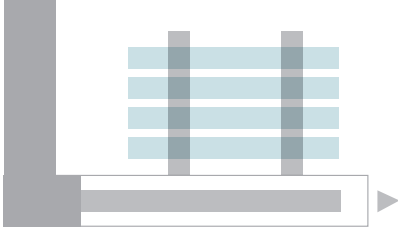

**Paralela** | Parallel | Parallèle

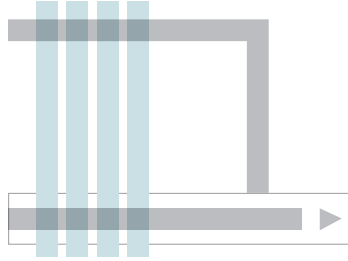

**Perpendicular** | Perpendicular | Perpendiculaire

\* Consultar para proyectos a medida  
Please consult us for made-to-measure projects  
Projets personnalisés sur demande

### Sección tipo

Cros-section | Section type (Cotas en mm | Dimensions in mm | Dimensions en mm)

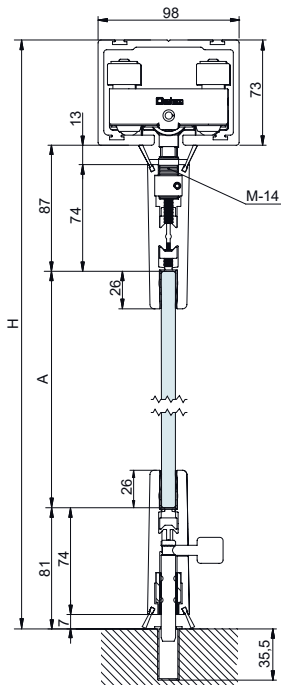

A=H-241



## Componentes

Components | Composants

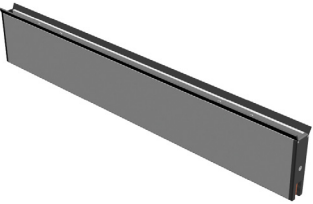
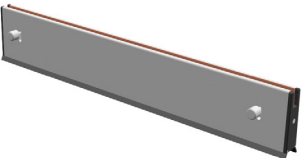
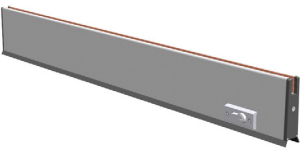
PERFILERÍA   PROFILES   PROFILS	Acabado	Cód.		
 <p>Perfil SV-P150 SV-P150 Track Rail SV-P150</p>  <p>98x73mm</p>	S	0 990 30		
ACCESORIOS   ACCESSORIES   ACCESSOIRES	Acabado	Cód.		
 <p>Pinza Reg. <b>SV-P150</b> Superior de: 60-70-80-90-100-110-120cm SV-P150. Top clamp: 60-70-80-90-100-110-120cm Pince rég. SV-P150 supérieure de: 60-70-80-90-100-110-120cm</p> <p>Componentes <b>SV-P150</b> Pinza Sup. 60-80cm SV-P150. Top clamp components. 60-80cm Composants SV-P150 pince sup. 60-80cm</p> <p>Componentes <b>SV-P150</b> Pinza Sup. +80-120cm SV-P150. Top clamp components. +80-120cm Composants SV-P150 pince sup. +80-120cm</p>		0 267 ...  0 267 51  0 267 52		
 <p>Pinza Reg. <b>SV-P150</b> Inferior de: 60-70-80-90-100-110-120cm SV-P150. Bottom clamp: 60-70-80-90-100-110-120cm Pince rég. SV-1250 inférieure de: 60-70-80-90-100-110-120cm</p> <p>Componentes <b>SV-P150</b> Pinza Inf. 60-80cm SV-P150. Bottom clamp components. 60-80cm Composants SV-P150 pince inf. 60-80cm</p> <p>Componentes <b>SV-P150</b> Pinza Inf. +80-120cm SV-P150. Bottom clamp components. +80-120cm Composants SV-P150 pince inf. +80-120cm</p>		0 268 ...  0 268 51  0 268 52		
 <p>Pinza Reg. <b>SV-P150</b> Inf. Con Cerradura de: 60-70-80-90-100-110-120 cm SV-P150. Bottom clamp with lock: 60-70-80-90-100-110-120 cm Pince rég. SV-P150 Inf. C/serrure de: 60-70-80-90-100-110-120 cm</p> <p>Componentes <b>SV-P150</b> Pinza Inf. Con cerradura 60-80 cm SV-P150. Bottom clamp with lock components. 60-80 cm Composants SV-P150 pince inf. avec serrure 60-80 cm</p> <p>Componentes <b>SV-P150</b> Pinza Inf. con cerradura 81-120 cm SV-P150. Bottom clamp with lock components 81-120 cm Composants SV-P150 pince inf. avec serrure 81-120 cm</p>		0 271 ...  0 271 51  0 271 52		



## Componentes

### Components | Composants

ACCESORIOS   ACCESSORIES   ACCESSOIRES		Acabado	Cód.		
	<p>Pinza Reg. <b>SV-P150</b> Superior Batiente de: 60-70-80-90-100-110-120 cm SV-P150. Top swinging clamp: 60-70-80-90-100-110-120 cm Pince rég. SV-P150 Supérieur battant de: 60-70-80-90-100-110-120 cm</p>		0 269 ...		
	<p>Componentes <b>SV-P150</b> Pinza sup. batiente 60-80 cm SV-P150 Top hinged clamp components. 60-80 cm Composants SV-P150 pince sup. battant 60-80 cm</p>		0 269 51		
	<p>Componentes <b>SV-P150</b> Pinza sup. batiente 81-120 cm SV-P150 Top hinged clamp components. 81-120 cm Composants SV-P150 pince sup. battant 81-120 cm</p>		0 269 52		
	<p>Pinza Reg. <b>SV-P150</b> Inferior Batiente de: 60-70-80-90-100-110-120 cm SV-P150. Bottom swinging clamp: 60-70-80-90-100-110-120 cm Pince rég. SV-P150 Inférieur battant de: 60-70-80-90-100-110-120 cm</p>		0 270 ...		
	<p>Componentes <b>SV-P150</b> Pinza inf. batiente 60-80 cm SV-P150 Bottom hinged clamp components. 60-80 cm Composants SV-P150 pince inf. battant 60-80 cm</p>		0 270 51		
	<p>Componentes <b>SV-P150</b> Pinza inf. batiente 81-120 cm SV-P150 Bottom hinged clamp components. 81-120 cm Composants SV-P150 pince inf. battant 81-120 cm</p>		0 270 52		
	<p>Roldana <b>S-P150</b> (M14) S-P150 roller (M14) Galet S-P150 (M14)</p>		0 156 55		
	<p>Curva parking <b>S-P150</b> 90° S-P150 90° parking bend Courbe parking S-P150 90°</p>		0 156 67		



## Componentes

Components | Composants

ACCESORIOS   ACCESSORIES   ACCESSOIRES		Acabado	Cód.		
	Cruce "T" <b>SV-P150</b> 90° SV-P150 90° "T" cross piece Croisement "T" SV-P150 90°		0 156 64		
	Cruce "X" <b>SV-P150</b> 90° SV-P150 90° "X" cross piece Croisement "X" SV-P150 90°		0 156 65		
	Embellecedor final perfil Track final trim Enjoliveur final rail		0 266 28		
	Junta recto unión perfil <b>SV-P150</b> SV-P150 track joint straight seal Joint franc de raccord au rail SV-P150		0 266 83		
	Cepillo para pinza Brush for grip Brosse pour pince		0 266 29 (19mm) 0 266 30 (14mm)	3m 3m	
	Cepillo Autoadhesivo Salvacantos Railsaver self-adhesive brush Brosse autoadhésive protège-coins		0 266 31	3m	



**Componentes**

Components | Composants

ACCESORIOS   ACCESSORIES   ACCESSOIRES		Acabado	Cód.		
	<p>Perfil Plastico Salvacantos Plastic strip railsaver Rail plastique protège-coins</p>		00 86 30	3m	
	<p>Tope Freno <b>SV-P150/P250</b> SV-P150/P250 brake stopper Butée d'arrêt SV-P150/P250</p>		0 266 61		
	<p>Llaves <b>SV-P150/P250</b> SV-P150/P250 wrenchs Clés SV-P150/P250</p>		0 266 62		
	<p>Cerradero suelo redondo hoja central Central panel round floor lock Gâche sol ronde battant central</p>		0 266 63		
	<p>Cerradero suelo redondo 15 mm Hoja Batiente Swing panel 15 mm round floor lock Gâche sol ronde 15 mm porte pivotante avec serrure</p>		0 266 81		
	<p>Soporte Giratorio Inferior Batiente Swing bottom turning support Support giratoire inférieur pivotante</p>		0 266 80		



## Parking Glass

SV-P250

# PARKING GLASS

BIBLIOTECA  
DE DESCARGAS



DOWNLOADS LIBRARY |  
BIBLIOTHÈQUE  
TÉLÉCHARGEMENTS

— ES

**SV-P250 ES EL CERRAMIENTO MÓVIL PARA HABILITAR GRANDES ESPACIOS. UNA SOLUCIÓN IDEAL PARA LA CREACIÓN DE AMBIENTES DISTINTOS DE USO COMERCIAL DE GRAN FORMATO.**

1.Sistema que permite montar infinitas hojas de vidrio de hasta 250kg.  
2.Roldanas con rodamientos a bolas de alta precisión y suavidad en el deslizamiento, además de regulación vertical. 3.Instalación sin perfil inferior, de modo que no proporciona un paso 100% libre de obstáculos una vez abierto; asimismo, dispone de pivotes de seguridad para fijar las hojas al suelo. 4.La peculiaridad de este modelo es la zona de estacionamiento de las hojas, conocida como "parking"; la cual es muy reducida y permite estacionar los paneles donde se desee, perpendicularmente y paralelamente a la instalación. 5.Un ligero deslizamiento de las hojas y un sistema regulable al milímetro para agilizar su instalación. 6.El conjunto SV-P250 forma una gran pantalla de vidrio una vez cerrado, dejando lugar a un acabado limpio de marcos, perfiles y sin barreras arquitectónicas. 7.Certificado para el viento.

— ES

**THE SV-P250 IS A MOBILE CLOSING SYSTEM DESIGNED FOR LARGE SPACES; AN IDEAL SOLUTION FOR CREATING DIFFERENT ENVIRONMENTS FOR LARGE-SCALE COMMERCIAL USE.**

1.A system that makes it possible to assemble an infinite number of glass panels of up to 250 kg. 2.High precision rollers with ball bearings for a smooth sliding action, as well as vertical adjustment. 3.The installation has no bottom guide channel, providing 100% obstacle-free passage once open. It also has safety pivots to attach the panels to the floor. 4.The particular feature of this model is the panel parking area, which is very small, and allows the panels to be parked where desired, perpendicularly and parallel to the installation. 5.The panels slide easily and the system is adjustable to the millimeter for ease of installation. 6.The SV-P250 assembly becomes a large glass screen once closed, providing a finish free of frames and profiles, and without architectural barriers.7. Certified for wind.

— ES

**SV-P250 ST UNE HUISSERIE MOBILE DESTINÉE À L'AMÉNAGEMENT DE GRANDS ESPACES. UNE SOLUTION IDÉALE POUR LA CRÉATION D'ESPACES DIFFÉRENCIÉS DANS DES LOCAUX À USAGE COMMERCIAL ET GRAND FORMAT.**

1.Système qui permet de monter un grand nombre de battants en verre d'un maximum de 250 kg. 2.Montures sur roulements à billes haute précision tout en douceur dans le glissement, plus réglage vertical. 3.Installation sans profil inférieur qui offre ainsi un passage 100 % libre d'obstacles une fois ouverte. Dispose également de pivots de sécurité pour fixer les battants au sol. 4.Ce modèle se distingue par sa zone de stationnement des battants, appelée « parking ». Très réduite, cette zone permet de stationner les panneaux là où on le désire, perpendiculairement et parallèlement à l'installation. 5.Un léger glissement des battants et un système réglable au millimètre près permettent de faciliter l'installation. 6.Une fois fermé, l'ensemble SV-P250 forme un vaste écran vitré qui arbore une finition libre de cadres, de profils et de barrières architecturales. 7.Certifié résistant au vent.





### Características técnicas

Technical characteristics | Caractéristiques techniques

### Perfilería Profiles | Profils



77x60 mm

### Especificaciones Specifications | Spécification



10-12 mm



MÍN.600 mm

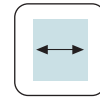

MÁX.1200 mm

### Peso Weight | Poids

250 kg

551 lb

### Producto certificado

Certificaded product | Produit certifié





### Variantes de instalación

Installation possibilities | Variantes d'installation

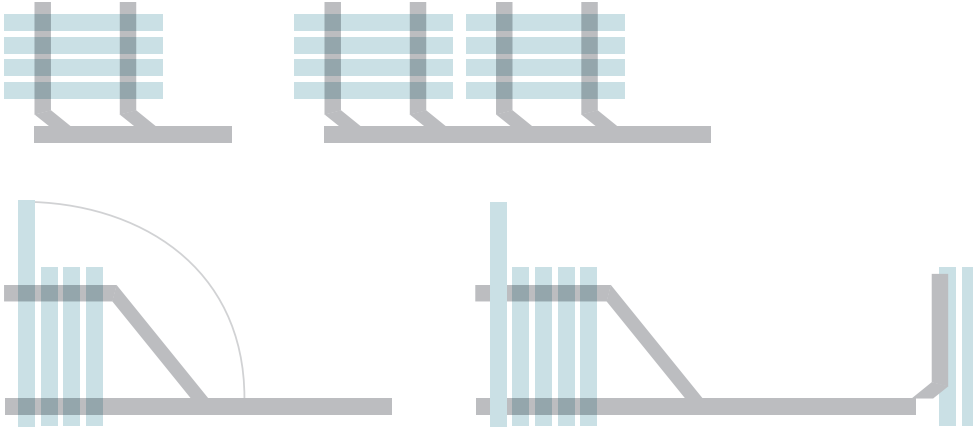

Consultar para proyectos a medida | Please consult us for made-to-measure projects | Projets personnalisés sur demande

### Sección tipo

Cros-section | Section type (Cotas en mm | Dimensions in mm | Dimensions en mm)

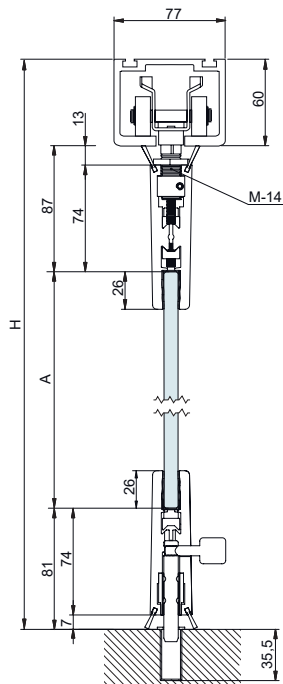

A=H-288



## Componentes

Components | Composants

PERFILERÍA   PROFILES   PROFILS	Acabado	Cód.		
 <p>Perfil <b>SV-P250</b> 100 cm                      SV-P250 track 100 cm                      Rail SV-P250 100 cm</p>  <p>77x60mm</p>	<b>S</b>	0 990 29		
ACCESORIOS   ACCESSORIES   ACCESSOIRES	Acabado	Cód.		
 <p>Pinza Reg. <b>SV-P250</b> Superior de:                      60-70-80-90-100-110-120cm                      SV-P250. Top clamp:                      60-70-80-90-100-110-120cm                      Pince rég. SV-P250 supérieure de:                      60-70-80-90-100-110-120cm</p> <p>Componentes <b>SV-P250</b> Pinza Sup. 60-80cm                      SV-P250. Top clamp components. 60-80cm                      Composants SV-P250 pince sup. 60-80cm</p> <p>Componentes <b>SV-P250</b> Pinza Sup. +80-120cm                      SV-P250. Top clamp components. +80-120cm                      Composants SV-P250 pince sup. +80-120cm</p>		0 267 ...  0 267 51  0 267 52		
 <p>Pinza Reg. <b>SV-P250</b> Inferior de:                      60-70-80-90-100-110-120cm                      SV-P250. Bottom clamp:                      60-70-80-90-100-110-120cm                      Pince rég. SV-P250 inférieure de:                      60-70-80-90-100-110-120cm</p> <p>Componentes <b>SV-P250</b> Pinza Inf. 60-80cm                      SV-P250. Bottom clamp components. 60-80cm                      Composants SV-P250 pince inf. 60-80cm</p> <p>Componentes <b>SV-P250</b> Pinza Inf. +80-120cm                      SV-P250. Bottom clamp components. +80-120cm                      Composants SV-P250 pince inf. +80-120cm</p>		0 268 ...  0 268 51  0 268 52		
 <p>Pinza Reg. <b>SV-P250</b> Inf. Con Cerradura de:                      60-70-80-90-100-110-120 cm                      SV-P250. Bottom clamp with lock:                      60-70-80-90-100-110-120 cm                      Pince rég. SV-P250 Inf. C/serrure de:                      60-70-80-90-100-110-120 cm</p> <p>Componentes <b>SV-P250</b> Pinza Inf. Con cerradura                      60-80 cm                      SV-P250. Bottom clamp with lock components.                      60-80 cm                      Composants SV-P250 pince inf. avec                      serrure 60-80 cm</p> <p>Componentes <b>SV-P250</b> Pinza Inf. con cerradura                      81-120 cm                      SV-P250. Bottom clamp with lock components                      81-120 cm                      Composants SV-P250 pince inf. avec serrure                      81-120 cm</p>		0 271 ...  0 271 51  0 271 52		



## Componentes

### Components | Composants

ACCESORIOS   ACCESSORIES   ACCESSOIRES		Acabado	Cód.		
	Pinza Reg. <b>SV-P250</b> Superior Batiente de: 60-70-80-90-100-110-120 cm SV-P250. Top swinging clamp: 60-70-80-90-100-110-120 cm Pince rég. SV-P250 Supérieur battant de: 60-70-80-90-100-110-120 cm		0 269 ...		
	Componentes <b>SV-P250</b> Pinza sup. batiente 60-80 cm SV-P250 Top hinged clamp components. 60-80 cm Composants SV-P250 pince sup. battant 60-80 cm		0 269 51		
	Componentes <b>SV-P250</b> Pinza sup. batiente 81-120 cm SV-P250 Top hinged clamp components. 81-120 cm Composants SV-P250 pince sup. battant 81-120 cm		0 269 52		
	Pinza Reg. <b>SV-P250</b> Inferior Batiente de: 60-70-80-90-100-110-120 cm SV-P250. Bottom swinging clamp: 60-70-80-90-100-110-120 cm Pince rég. SV-P250 Inférieur battant de: 60-70-80-90-100-110-120 cm		0 270 ...		
	Componentes <b>SV-P250</b> Pinza inf. batiente 60-80 cm SV-P250 Bottom hinged clamp components. 60-80 cm Composants SV-P250 pince inf. battant 60-80 cm		0 270 51		
	Componentes <b>SV-P250</b> Pinza inf. batiente 81-120 cm SV-P250 Bottom hinged clamp components. 81-120 cm Composants SV-P250 pince inf. battant 81-120 cm		0 270 52		
	Cruce de 135° <b>SV-P250</b> park. perp. izdo. "A" SV-P250 left perp. park. 135° junction "A" Guide de dérivation de 135° SV-P250 park. perp. gauche "A"		0 266 64		
	Curva 45° <b>SV-P250</b> park. perp. "IC" SV-P250 perp. park. 45° curve "IC" Guide en courbe 45° SV-P250 park. perp. "IC"		0 266 66		
	Cruce de 135° <b>SV-P250</b> park. perp. dcho. "B" SV-P250 right perp. park. 135° junction "B" Guide de dérivation de 135° SV-P250 park. perp. droit "B"		0 266 65		
	Curva 45° <b>SV-P250</b> park. perp. "DC" SV-P250 perp. park. 45° curve "DC" Guide en courbe 45° SV-P250 park. perp. "DC"		0 266 67		



## Componentes

### Components | Composants

ACCESORIOS   ACCESSORIES   ACCESSOIRES	Acabado	Cód.		
 <p>Cruce de 90° <b>SV-P250</b> park. paralelo izdo. "E"  SV-P250 left parallel park. 90° junction "E"  Guide de dérivation de 90° SV-P250 park.  parallèle gauche "E"</p> <p>Curva 90° <b>SV-P250</b> park. paralelo izdo. "I", "F"  SV-P250 left parallel park. 90° curve "I", "F"  Guide en courbe 90° SV-P250 park.  parallèle gauche "I", "F"</p>		<p>0 266 71</p> <p>0 266 68</p>		
 <p>Cruce de 90° <b>SV-P250</b> park. paralelo dcho. "G"  SV-P250 right parallel park. 90° junction "G"  Guide de dérivation de 90° SV-P250 park.  parallèle droit "G"</p> <p>Curva 90° <b>SV-P250</b> park. paralelo dcho. "D", "F"  SV-P250 right parallel park. 90° curve "D", "F"  Guide en courbe 90° SV-P250 park.  parallèle droit "D", "F"</p>		<p>0 266 70</p> <p>0 266 69</p>		
 <p>Roldana <b>SV-P250</b> (M14)  SV-P250 roller (M14)  Galet SV-P250 (M14)</p>		<p>0 266 55</p>		
 <p>Embellecedor final perfil  Final trim track  Capuchon final rail</p>		<p>0 266 27</p>		
 <p>Junta recto unión perfil <b>SV-P250</b>  SV-P250 profile joint straight seal  Joint franc de raccord au profil SV-P250</p>		<p>0 266 82</p>		
 <p>Cepillo para pinza  Brush for grip  Brosse pour pince</p>		<p>0 266 29 (19mm)</p> <p>0 266 30 (14mm)</p>	<p>3m</p> <p>3m</p>	



**Componentes**

Components | Composants

ACCESORIOS   ACCESSORIES   ACCESSOIRES		Acabado	Cód.		
	Cepillo Autoadhesivo Salvacantos Railsaver self-adhesive brush Brosse autoadhésive protège-coins		0 266 31	3m	
	Perfil Plastico Salvacantos Plastic strip railsaver Profilé plastique protège-coins		00 86 30	3m	
	Tope Freno <b>SV-P150/P250</b> SV-P150/P250 brake stopper Butée d'arrêt SV-P150/P250		0 266 61		
	Llaves <b>SV-P150/P250</b> SV-P150/P250 Wrenches Clés SV-P150/P250		0 266 62		
	Cerradero suelo redondo hoja central Central panel round floor lock Gâche sol ronde battant central		0 266 63		
	Cerradero suelo redondo 15mm Swing panel 15mm round floor lock Gâche sol ronde 15mm battant central avec serrure		0 266 81		
	Soporte giratorio inferior batiente Swing bottom turning support Support giratoire inférieur pivotante		0 266 80		



## Plicat Glass

SV-A101D

# PLICAT GLASS

BIBLIOTECA  
DE DESCARGAS



DOWNLOADS LIBRARY |  
BIBLIOTHÈQUE  
TÉLÉCHARGEMENTS

— ES

**SV-A101D ES UNO DE LOS SISTEMAS PLEGABLES DE SAHECO CREADOS PARA GANAR ESPACIO HACIA EL EXTERIOR Y CREAR DIVISIONES DE ESPACIOS INTERIORES DE USO DOMÉSTICO DE PESO MEDIO O GRAN FORMATO.**

**1.**Sistema para hojas correderas plegables de 100kg/par de hojas (tipo acordeón) que permite desplazar todos los paneles a la vez. **2.**Nos permite cerrar hasta 9 m de ancho por 2,65 m de alto. **3.**Roldanas de gran resistencia y guidores inferiores de alta calidad para evitar los posibles balanceos del sistema.

Teniendo entre sus aplicaciones la opción de cerramiento para exteriores, cabe destacar que esta solución dispone de bisagras macizas anti-vandálicas; de modo que además de que los mecanizados quedan en la parte interior del cerramiento, y por lo tanto ofrecen un perfecto acabado, también nos proporciona un cerramiento de seguridad.

— ES

**THE SV-A101D IS ONE OF SAHECO'S HINGED SYSTEMS CREATED TO SAVE SPACE TOWARDS THE OUTSIDE AND CREATE INTERIOR SPACE DIVIDERS FOR MEDIUM WEIGHT OR LARGE FORMAT DOMESTIC USES.**

**1.**A system of hinged sliding panels of 100 kg/pair of panels (concertina type) that allows all the panels to be moved at the same time. **2.**It possible to close an opening of up to 9 m wide by 2.65 m high. **3.**High strength rollers and high quality bottom guides to prevent any possible sway in the system.

Note that this solution has solid anti-vandal hinges; so in addition to the fact that the machining is on the inside of the panels, thereby providing a perfect finish, it also provides security in terms of closing.

— ES

**SV-A101D COMPTE PARMİ LES SYSTÈMES PLIANTS DE SAHECO, CONÇUS POUR GAGNER DE L'ESPACE SUR L'EXTÉRIEUR ET CRÉER DES AMÉNAGEMENTS INTÉRIEURS À USAGE RÉSIDENTIEL DE POIDS MOYEN OU GRAND FORMAT.**

**1.**Système pour battants coulissants pliants de 100 kg/couple de battants (type accordéon) qui permet de déplacer tous les panneaux à la fois. **2.**Permettant de fermer jusqu'à 9 m de large par 2,65 m de haut. **3.**Montures très résistantes et guides inférieurs de grande qualité pour les éventuels balancements du dispositif.

Option de huisserie d'extérieur disponible: cette solution dispose de charnières massives antivandalisme dont les parties usinées se situent à l'intérieur des portes, pour une finition parfaite et plus de sécurité.





### Características técnicas

Technical characteristics | Caractéristiques techniques

### Perfilería Profiles | Profils



54x53 mm

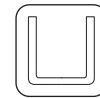

20x20 mm

### Especificaciones Specifications | Spécification

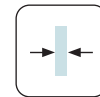

8-10 mm



MÁX. 6+6 HOJAS |  
PANELS | PANNEAUX

2.650mm

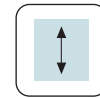

SIN BISAGRA INTERMEDIA  
WITHOUT INTERMEDIATE HINGE  
SANS CHARNIÈRE INTERMÉDIAIRE

+ 2.650mm

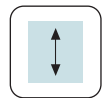

BISAGRA INTERMEDIA  
INTERMEDIATE HINGE  
CHARNIÈRE INTERMÉDIAIRE

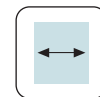

MÁX.750 mm



RODAMIENTO A BOLAS  
BALL BEARING  
ROULEMENT À BILLES

### Peso Weight | Poids

100 kg

221 lb

Por par de hojas | Per pair of panels | Par paire de panneaux

### Producto certificado

Certificaded product | Produit certifié



### Variantes de instalación

Installation possibilities | Variantes d'installation

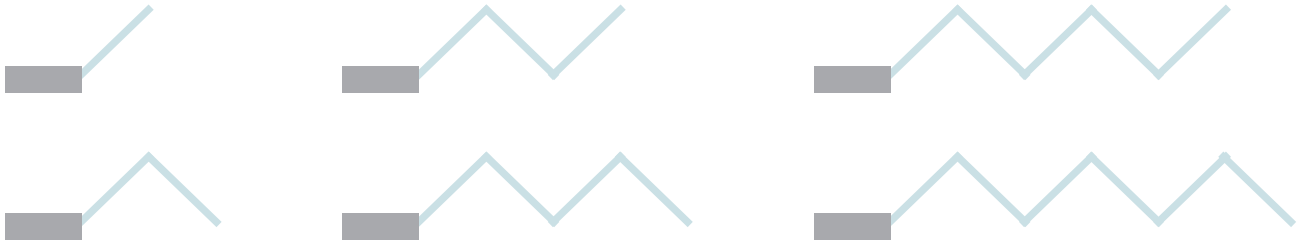

### Sección tipo



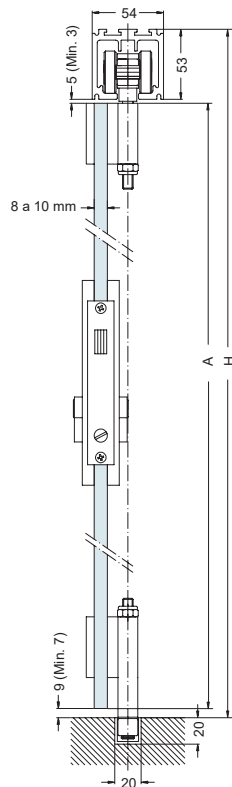



Cros-section | Section type (Cotas en mm | Dimensions in mm | Dimensions en mm)



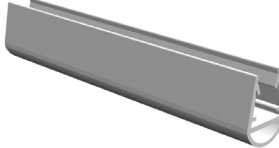

## Componentes

Components | Composants











PERFILERÍA   PROFILES   PROFILS		Acabado	Cód.		
 <p>Perfil superior Top track Rail supérieur</p>  <p>54x53 mm</p>	S	0 256 15 0 256 22 0 256 30 0 256 37 0 256 45 0 256 60	1,5 m 2,25 m 3 m 3,75 m 4,5 m 6 m		1 perfil 1 profile 1 profil
 <p>Perfil inferior para vidrio fijo de 8-10-12mm Bottom track for fixed glass of 8-10-12mm Rail inférieur pour verre fixe de 8-10-12mm</p>  <p>20x20 mm</p>	S	00 87 15 00 87 30 00 87 60	1,5 m 3 m 6 m		2 perfiles 2 profiles 2 profils
ACCESORIOS   ACCESSORIES   ACCESSOIRES		Acabado	Cód.		
 <p>Perfil de plástico salvacantos Edge plastic track Rail plastique saving</p>		00 86 30	3 m		2 perfiles 2 profiles 2 profils
 <p>Roldana final con bisagra simple <b>SV-A101D</b> Rodamiento simple SV-A101D Final roller with simple hinge. Simple bearing Galet finale avec charnière simple SV-A101D Roulement simple</p>  <p>RODAMIENTO A BOLAS BALL BEARING ROULEMENT À BILLES</p>	S	0 107 70			1 pieza 1 piece 1 pièce
 <p>Roldana final con bisagra simple <b>SV-A101D</b> Doble Rodamiento SV-A101D Final roller with simple hinge. Double Bearing Galet finale avec charnière simple SV-A101D Double Roulement</p>  <p>RODAMIENTO A BOLAS BALL BEARING ROULEMENT À BILLES</p>	S	0 107 71			1 pieza 1 piece 1 pièce
 <p>Guiador inferior con bisagra simple <b>SV-A101D</b> SV-A101D Bottom guide with simple hinge Guide inférieur avec charnière simple SV-A101D</p>	S	0 107 72			1 pieza 1 piece 1 pièce

S Aluminio anodizado plata mate  
Satin anodized aluminium  
Aluminium anodisé argent



## Componentes

Components | Composants

ACCESORIOS   ACCESSORIES   ACCESSOIRES		Acabado	Cód.		
	<p>Roldana central con bisagra doble <b>SV-A101D</b>                      Doble Rodamiento                      SV-A101D Central roller with double hinge.                      Double Bearing                      Galet centrale avec charnière double SV-A101D. Double Roulement</p>  <p>RODAMIENTO A BOLAS                      BALL BEARING                      ROULEMENT À BILLES</p>		0 107 73		1 pieza 1 piece 1 pièce
	<p>Bisagra doble con pasador de pie <b>SV-A101D</b>                      SV-A101D Double hinge with leg pin                      Charnière double avec goupille verticale SV-A101D</p>		0 107 74		1 pieza 1 piece 1 pièce
	<p>Bisagra doble "A" central <b>SV-A101D</b>                      SV-A101D Double hinge "A" central                      Charnière double "A" centrale SV-A101D</p>		0 107 75		1 pieza 1 piece 1 pièce
	<p>Bisagra doble "B" central <b>SV-A101D</b>                      SV-A101D Double hinge "B" central                      Charnière double "B" centrale SV-A101D</p>		0 107 80		1 pieza 1 piece 1 pièce
	<p>Guiador central inferior con bisagra doble <b>SV-A101D</b>                      SV-A101D Bottom central guide with double hinge                      Guide central inférieur avec charnière double SV-A101D</p>		0 107 76		1 pieza 1 piece 1 pièce
	<p>Pivote superior con bisagra <b>SV-A101D</b>                      SV-A101D Superior pivot with hinge                      Pivot supérieur avec charnière SV-A101D</p>		0 107 77		1 pieza 1 piece 1 pièce



Aluminio anodizado plata mate  
 Satin anodized aluminium  
 Aluminium anodisé argent



## Componentes

### Components | Composants

ACCESORIOS   ACCESSORIES   ACCESSOIRES		Acabado	Cód.		
	Pivote inferior con bisagra <b>SV-A101D</b> SV-A101D Bottom pivot with hinge Pivot inférieur avec charnière SV-A101D	S	0 107 78		1 pieza 1 piece 1 pièce
	Pasador de pie <b>SV-A101D</b> SV-A101D Leg pin Goupille verticale SV-A101D	S	0 107 79		1 pieza 1 piece 1 pièce
	Cerradura con gancho para puerta corredera de vidrio Glass sliding door lock with strike plate Serrure pour porte coulissante en verre avec gâchet	S PC 304	00 66 60 <sup>1</sup> 00 66 62 <sup>1</sup> 00 66 65 <sup>1</sup>	8/10 mm 8/10 mm 8/10 mm	1 pieza 1 piece 1 pièce
	Cerradura para puerta corredera de vidrio Glass sliding door lock Serrure pour porte coulissante en verre	S PC 304	00 66 61 00 66 63 00 66 66	8/10 mm 8/10 mm 8/10 mm	1 pieza 1 piece 1 pièce
	Burlete, escobilla Brush strip Burlete, brosse		00 86 31	2,5 m	2 perfiles 2 profiles 2 profils
	Tapa perfil Track cap Capuchon pour rail	PPS	0 300 57		25 piezas 25 pieces 25 pièces

\*No se pueden amaestrar las llaves | \*Master keys not available | \*Crochetage de clés n'est pas disponible

**S** Aluminio anodizado plata mate  
Satin anodized aluminium  
Aluminium anodisé argent

**PC** Aluminio pulido cromado  
Chrome polished aluminium  
Aluminium polie chromé  
Brillante | Shiny | Brillant

**304** Inox  
Stainless  
Steel

**PPS** Plástico pintado plata  
Plastic painted silver  
PVC finition peinture argent



# Plicat Glass

SV-I100D

# PLICAT GLASS

BIBLIOTECA  
DE DESCARGAS



DOWNLOADS LIBRARY |  
BIBLIOTHÈQUE  
TÉLÉCHARGEMENTS

ES

**SV-I100D ES OTRO DE LOS SISTEMAS PLEGABLES DE SAHECO CREADOS PARA GANAR ESPACIO HACIA EL EXTERIOR Y CREAR DIVISIONES DE ESPACIOS INTERIORES DE USO DOMÉSTICO DE PESO MEDIO O GRAN FORMATO.**

1.Sistema para hojas correderas plegables de 100kg/par de hojas (tipo acordeón) que permite desplazar todos los paneles a la vez. 2.Nos permite cerrar hasta 9 m de ancho por 2,65 m de alto. 3.Roldanas de gran resistencia y guidores inferiores de alta calidad para evitar los posibles balanceos del sistema. 4.Cabe destacar que esta solución dispone de bisagras recubiertas con tapeta de inoxidable y mecanizados que quedan en la parte interior del cerramiento, ofreciendo un perfecto acabado. 5.Especialmente diseñado para aportar una imagen muy compacta y elegante, en terrazas, porches y jardines.

ES

**THE SV-I100D IS ANOTHER OF SAHECO'S HINGED SYSTEMS CREATED TO SAVE SPACE TOWARDS THE OUTSIDE AND CREATE INTERIOR SPACE DIVIDERS FOR MEDIUM WEIGHT OR LARGE FORMAT DOMESTIC USES.**

1.A system of hinged sliding panels of 100 kg/pair of panels (concertina type) that allows all the panels to be moved at the same time. 2.It possible to close an opening of up to 9 m wide by 2.65 m high. 3.High strength rollers and high quality bottom guides to prevent any possible sway in the system. 4.Note that this solution has hinges with machined stainless steel covers that remain inside the closing system, thus providing a perfect finish. 5.Specially designed to provide a highly compact and elegant image in terraces, porches and gardens.

ES

**SV-I100D COMPTE PARMİ LES SYSTÈMES PLIANTS DE SAHECO, CONÇUS POUR GAGNER DE L'ESPACE SUR L'EXTÉRIEUR ET CRÉER DES AMÉNAGEMENTS INTÉRIEURS À USAGE RÉSIDENTIEL DE POIDS MOYEN OU GRAND FORMAT.**

1.Système pour battants coulissants pliants de 100 kg/couple de battants (type accordéon) qui permet de déplacer tous les panneaux à la fois. 2.Permettant de fermer jusqu'à 9 m de large par 2,65 m de haut. 3.Montures très résistantes et guides inférieurs de grande qualité pour les éventuels balancements du dispositif. 4.À signaler que cette solution dispose de charnières recouvertes d'un cache en acier inoxydable et usinées, qui restent sur la partie intérieure de la huisserie et assurent ainsi une finition parfaite. 5.Spécialement conçu pour doter terrasses, porches et jardins d'une ligne compacte et élégante.





### Características técnicas

Technical characteristics | Caractéristiques techniques

### Perfilería Profiles | Profils



54x53mm

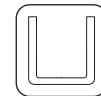

20x20mm

### Especificaciones Specifications | Spécification

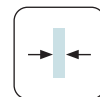

10-12 mm



MÁX. 6+6 HOJAS |  
PANELS | PANNEAUX

2.650mm

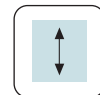

SIN BISAGRA INTERMEDIA  
WITHOUT INTERMEDIATE HINGE  
SANS CHARNIÈRE INTERMÉDIAIRE

+ 2.650mm

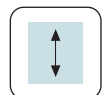

BISAGRA INTERMEDIA  
INTERMEDIATE HINGE  
CHARNIÈRE INTERMÉDIAIRE

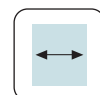

MÁX. 745 mm



RODAMIENTO A BOLAS  
BALL BEARING  
ROULEMENT À BILLES

### Peso Weight | Poids

100 kg

221 lb

Por par de hojas | Per pair of panels | Par paire de panneaux

### Producto certificado

Certificaded product | Produit certifié





### Variantes de instalación

Installation possibilities | Variantes d'installation

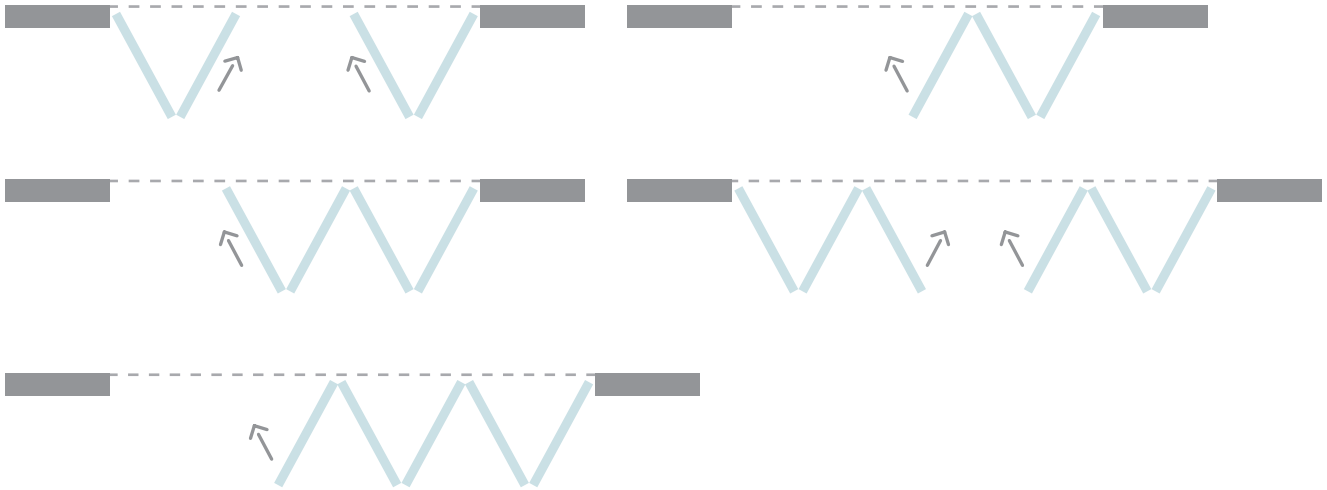

### Sección tipo

Cros-section | Section type (Cotas en mm | Dimensions in mm | Dimensions en mm)

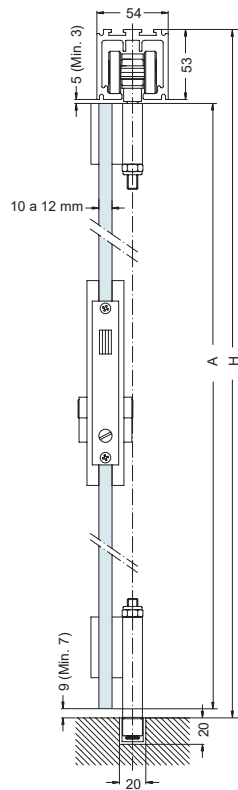



## Componentes

Components | Composants

PERFILERÍA   PROFILES   PROFILS		Acabado	Cód.		
	<p>Perfil superior Top track Rail supérieur</p>  <p>54x53mm</p>	<b>S</b>	<p>0 256 15 0 256 22 0 256 30 0 256 37 0 256 45 0 256 60</p>	<p>1,5 m 2,25 m 3 m 3,75 m 4,5 m 6 m</p>	<p>1 perfil 1 profile 1 profil</p>
	<p>Perfil inferior para vidrio fijo de 8-10-12mm Bottom track for fixed glass of 8-10-12mm Rail inférieur pour verre fixe de 8-10-12mm</p>  <p>20x20mm</p>	<b>S</b>	<p>00 87 15 00 87 30 00 87 60</p>	<p>1,5 m 3 m 6 m</p>	<p>2 perfiles 2 profiles 2 profils</p>
ACCESORIOS   ACCESSORIES   ACCESSOIRES		Acabado	Cód.		
	<p>Perfil plástico salvacantos Edge plastic track Rail plastique protecting</p>		00 86 30	3 m	<p>2 perfiles 2 profiles 2 profils</p>
	<p>Roldana final con bisagra simple <b>SV-I100D</b> Rodamiento simple SV-I100D Final roller with simple hinge.Simple Bearing Galet finale inox avec charnière simple SV-I100D. Roulement simple</p>  <p>RODAMIENTO A BOLAS BALL BEARING ROULEMENT À BILLES</p>	<b>304</b>	0 108 70		<p>1 pieza 1 piece 1 pièce</p>
	<p>Roldana final con bisagra simple <b>SV-I100D</b> Doble Rodamiento SV-I100D Final roller with simple hinge.Double Bearing Galet finale inox avec charnière simple SV-I100D Double Roulement</p>  <p>RODAMIENTO A BOLAS BALL BEARING ROULEMENT À BILLES</p>	<b>304</b>	0 108 71		<p>1 pieza 1 piece 1 pièce</p>
	<p>Guiador inferior con bisagra simple <b>SV-I100D</b> SV-I100D Bottom guide with simple hinge Guide inférieur avec charnière simple SV-I100D</p>  <p>RODAMIENTO A BOLAS BALL BEARING ROULEMENT À BILLES</p>	<b>304</b>	0 108 72		<p>1 pieza 1 piece 1 pièce</p>

**S** Aluminio anodizado plata mate  
Satin anodized aluminium  
Aluminium anodisé argent

**304** Inox  
Stainless  
Steel



## Componentes

Components | Composants

ACCESORIOS   ACCESSORIES   ACCESSOIRES		Acabado	Cód.		
	<p>Roldana central con bisagra doble <b>SV-I100D</b>.                      Doble Rodamiento                      SV-I100D Central roller with hinge double.                      Double Bearing                      Galet centrale avec charnière double SV-I100D.                      Double Roulement</p>	304	0 108 73		1 pieza 1 piece 1 pièce
	<p>Bisagra doble con pasador de pie <b>SV-I100D</b>                      SV-I100D Double hinge with leg pin                      Charnière double avec goupille verticale SV-I100D</p>	304	0 108 74		1 pieza 1 piece 1 pièce
	<p>Bisagra doble central <b>SV-I100D</b>                      SV-I100D Double hinge central                      Charnière double centrale SV-I100D</p>	304	0 108 75		1 pieza 1 piece 1 pièce
	<p>Guiador central inferior con bisagra doble <b>SV-I100D</b>                      SV-I100D Clear threshold bottom central guide with double hinge                      Guide central inférieur avec charnière double SV-I100D</p>	304	0 108 76		1 pieza 1 piece 1 pièce
	<p>Pivote superior con bisagra <b>SV-I100D</b>                      SV-I100D Top pivot with hinge                      Pivot supérieur avec charnière SV-I100D</p>	304	0 108 77		1 pieza 1 piece 1 pièce

304

Inox  
Stainless  
Steel



## Componentes

### Components | Composants

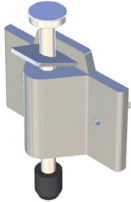
ACCESORIOS   ACCESSORIES   ACCESSOIRES	Acabado	Cód.		
 <p>Pivote inferior con bisagra <b>SV-I100D</b> SV-I100D Bottom pivot with simple hinge Pivot inférieur inox avec charnière SV-I100D</p>	304	0 108 78		1 pieza 1 pièce 1 pièce
 <p>Pasador de pie <b>SV-I100D</b> SV-I100D Leg pin Goupille verticale inox SV-I100D</p>	304	0 108 79		1 pieza 1 pièce 1 pièce
 <p>Cerradura con gancho para puerta corredera de vidrio Glass sliding door lock with strike plate Serrure pour porte coulissante en verre avec gâchet</p>	S PC 304	00 66 60 <sup>1</sup> 00 66 62 <sup>1</sup> 00 66 65 <sup>1</sup>	8-10 mm 8-10 mm 8-10 mm	1 pieza 1 pièce 1 pièce
 <p>Cerradura para puerta corredera de vidrio Glass sliding door lock Serrure pour porte coulissante en verre</p>	S PC 304	00 66 61 00 66 63 00 66 66	8-10 mm 8-10 mm 8-10 mm	1 pieza 1 pièce 1 pièce
 <p>Tapa perfil Track cap Capuchon pour rail</p>	PPS	0 300 57		25 piezas 25 pièces 25 pièces

<sup>1</sup>No se pueden amaestrar las llaves | <sup>1</sup>Master keys not available | <sup>1</sup>Crochetage de clés n'est pas disponible

304

Inox  
Stainless  
Steel

S

Aluminio anodizado plata mate  
Satin anodized aluminium  
Aluminium anodisé argent

PC

Aluminio pulido cromado  
Chrome polished aluminium  
Aluminium polie chromé  
Brillante | Shiny | Brillant

PPS

Plástico pintado plata  
Plastic painted silver  
PVC finition peinture argent



Proyecto by Luis Sanandrés Interiorismo

## Accesorio Frame Glass

SV-X70 | SV-X110



Proyecto by Cristalería Mosteiro

## FRAME GLASS

**Frame es un marco perimetral compatible con los sistemas X70 / X110 de la familia Compact Glass de Saheco. Con Frame puedes transformar tus puertas correderas de vidrio dando a tu hogar o comercio un toque elegante, moderno y minimalista. Adecuado para paneles de vidrio de 10 mm de grosor y un peso de 70 a 110 kg por hoja. Se ofrece en tres acabados: aluminio lacado negro mate, aluminio lacado blanco mate, y aluminio anodizado plata mate.**

Frame family offers a perimeter frame for glass panels. It is compatible with X70 / X110 systems of the Compact Glass family by Saheco. With Frame, you can transform your sliding glass doors giving your residence or commerce an elegant, modern and minimalist look. Suitable for glass panels of 10mm thickness and 70 to 110 kg per panel. It is offered in three finishes: Matt black lacquered aluminium, Matt white lacquered aluminium and matt silver anodized aluminum.

Frame est un cadre périmétral compatible avec les systèmes X70 / X110 de la famille Compact Glass de Saheco. Avec Frame, vous pouvez transformer votre porte coulissante en verre donnant à votre foyer ou commerce un aspect élégant, moderne et minimaliste. Approprié pour panneaux de verre de 10mm d'épaisseur et un poids de 70 à 110 kg par panneau. Nous l'offrons en trois finitions: Aluminium laqué noir mat, Aluminium laqué blanc mat et aluminium anodisé argent mat.

Proyecto by Luis Sanandrés Interiorismo













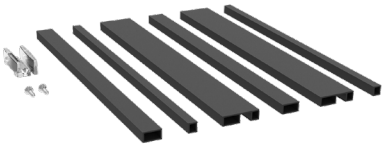
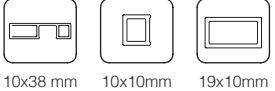













Proyecto by Vidres Claror



# Accesorio Frame

## Frame Accessory | Accessoire Frame

### Kit

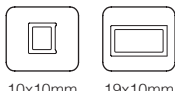
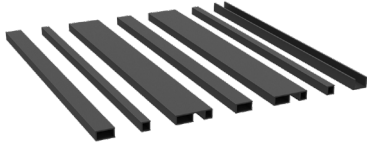
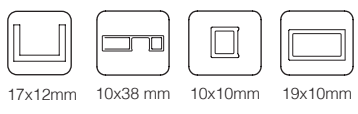
ACCESORIO FRAME   FRAME ACCESSORIE   ACCESSOIRE FRAME		Finished	Cód.	اساسيات	📦
<b>A</b> 	<p>Conjunto marco perimetral para puerta corredera <b>SV-X70/X110 FRAME</b> Perimeter frame set for sliding door SV-X70/X110 FRAME Kit cadre périmétral pour porte coulissante SV-X70/X110 FRAME</p>  <p>10x38 mm    10x10mm    19x10mm</p>	 S  WL  BL	0 111 22 0 111 41 0 111 27	 3 m 2 m	1 juego 1 set 1 jeu
		 S  WL  BL	0 111 12 0 111 42 0 111 13	 2,5 m 1 m	1 juego 1 set 1 jeu
		 S  WL  BL	0 111 20 0 111 43 0 111 25	3m	1 juego 1 set 1 jeu
		 S  WL  BL	0 111 28 0 111 44 0 111 29	 3m 2m	1 juego 1 set 1 jeu
		 S  WL  BL	0 111 14 0 111 45 0 111 15	 2,5 m 1 m	1 juego 1 set 1 jeu
		 S  WL  BL	0 111 32 0 111 31 0 111 37		1 juego 1 set 1 jeu
<b>B</b> 	<p>Conjunto división interna <b>SV-X70/X110 FRAME</b> Internal division set SV-X70/X110 FRAME Kit division interne SV-X70/X110 FRAME</p>  <p>10x10mm    19x10mm</p>				
<b>C</b> 	<p>Conjunto marco perimetral <b>SV-X70/X110 FRAME</b> para vidrio fijo. Compatible con perfil Frame y perfil FT vidrio fijo. Perimeter frame SV-X70/X110 FRAME for fixed glass. Compatible with Frame track and FT fixed glass track. Kit de cadre périmétral pour SV-X70/X110 FRAME verre fixe. Compatible avec le rail Frame et le rail FT verre fixe.</p>  <p>17x12mm    10x38 mm    10x10mm    19x10mm</p>				
	<b>Conjunto tiradores SV-X70/X110 FRAME</b> SV-X70/X110 FRAME handles set Jeu poignées SV-X70/X110 FRAME				

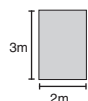

Medidas máx. de puerta  
Max. Sizes of doors  
Dimensions max. de porte

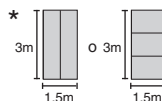









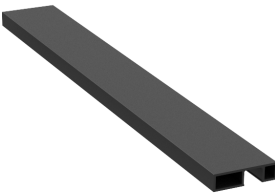

Añadir más kits según diseño  
Add more sets according to design  
Ajouter plus de kits selon design

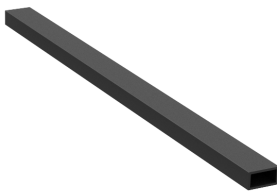
**WL** Aluminio lacado blanco mate  
Matt white lacquered aluminium  
Aluminium laqué blanc mat

**BL** Aluminio lacado negro mate  
Matt black lacquered aluminium  
Aluminium anodisé laqué noir mat

**S** Aluminio anodizado plata mate  
Satin anodized aluminium  
Aluminium anodisé argent

ACCESORIO FRAME   FRAME ACCESSORY   ACCESSOIRE FRAME		Finish	Cód.		
	<p>Perfil vertical <b>SV-X70/110 FRAME</b> 38,5x10                      Vertical track SV-X70/110 FRAME 38,5x10                      Rail vertical SV-X70/110 FRAME 38,5x10</p>  <p>10x38 mm</p>	<p><b>MF</b></p> <p><b>S</b></p> <p><b>WL</b></p> <p><b>BL</b></p>	<p>0 111 51<sup>1</sup></p> <p>0 111 33</p> <p>0 111 48</p> <p>0 111 35</p>	3m	2 perfiles 2 profiles 2 profils
	<p>Perfil horizontal <b>SV-X70/110 FRAME</b> 18,5x10                      Horizontal track SV-X70/110 FRAME 18,5x10                      Rail horizontal SV-X70/110 FRAME 18,5x10</p>  <p>19x10mm</p>	<p><b>MF</b></p> <p><b>S</b></p> <p><b>WL</b></p> <p><b>BL</b></p>	<p>0 111 52<sup>1</sup></p> <p>0 111 34</p> <p>0 111 49</p> <p>0 111 36</p>	3m	6 perfiles 6 profiles 6 profils
	<p>Perfil horizontal <b>SV-X70/110 FRAME</b> 10x10                      Horizontal track SV-X70/110 FRAME 10x10                      Rail horizontal SV-X70/110 FRAME 10x10</p>  <p>10x10mm</p>	<p><b>MF</b></p> <p><b>S</b></p> <p><b>WL</b></p> <p><b>BL</b></p>	<p>0 111 53<sup>1</sup></p> <p>0 111 38</p> <p>0 111 50</p> <p>0 111 39</p>	3m	6 perfiles 6 profiles 6 profils
	<p>Cinta adhesiva de doble cara 7mm                      Double-sided adhesive tape 7mm                      Ruban adhésif double face 7mm</p>		0 111 54	33m	1 pieza 1 piece 1 pièce
	<p>Guiador inferior plástico FRAME                      Plastic FRAME bottom guide                      FRAME guide inferior plastique</p>	<p><b>TP</b></p> <p><b>BP</b></p>	<p>0 111 57</p> <p>00 49 57</p>		25 piezas 25 pieces 25 pièces

<sup>1</sup> Se sirve sin cinta adhesiva | Served without double-sided tape | Est servi sans ruban adhésif double face

**WL** Aluminio lacado blanco mate  
Matt white lacquered aluminium  
Aluminium laqué blanc mat

**BL** Aluminio lacado negro mate  
Matt black lacquered aluminium  
Aluminium anodisé laqué noir mat

**TP** Plástico transparente  
Transparent plastic  
Plastique transparent

**BP** Plástico negro  
Black plastic  
Plastique noir

**MF** Aluminio natural  
Mill finish aluminium  
Aluminium brut

**S** Aluminio anodizado plata mate  
Satin anodized aluminium  
Aluminium anodisé argent

# Posibilidades de instalación X70 / X110

Installation possibilities X70 / X110 | Variantes d'installation X70 / X110

## Conjunto marco perimetral | Perimeter frame set | Kit de cadre périmétral

hasta 70 - 110 kg | 154 - 242 lb por hoja

TECHO  
CEILING  
PLAFOND

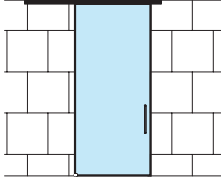

A

PARED  
WALL  
MUR

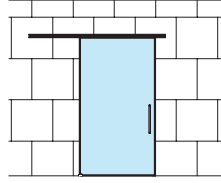

A

FALSO TECHO  
FALSE CEILING  
FAUX-PLAFOND

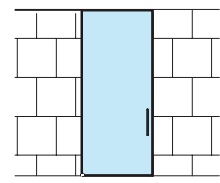

A

SV-X70 / X110

PARED DE VIDRIO  
GLASS WALL  
MUR DE VERRE

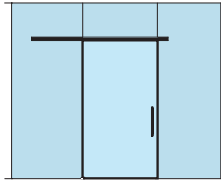

A

TECHO CON VIDRIO FIJO  
CEILING WITH FIXED GLASS  
PLAFOND AVEC VERRE FIXE

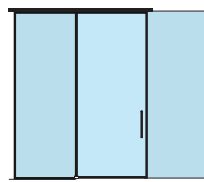

A + C \*

FALSO TECHO CON VIDRIO FIJO  
FALSE CEILING WITH FIXED GLASS  
FAUX-PLAFOND AVEC VERRE FIXE

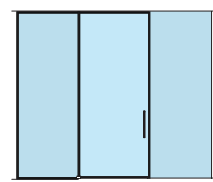

A + C

\* A+C Opción solo con conjunto perfil superior corredero para accesorio Frame | Option only with Top track set for Frame accessory | Option uniquement avec Jeu profil supérieur pour accessoire Frame.

## Conjunto división interna | Internal division set | Kit de division interne

TECHO  
CEILING  
PLAFOND

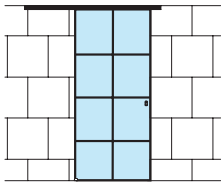

A + B

PARED  
WALL  
MUR

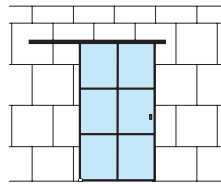

A + B

FALSO TECHO  
FALSE CEILING  
FAUX-PLAFOND

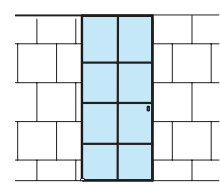

A + B

PARED DE VIDRIO  
GLASS WALL  
MUR DE VERRE

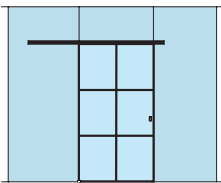

A + B

TECHO CON VIDRIO FIJO  
CEILING WITH FIXED GLASS  
PLAFOND AVEC VERRE FIXE

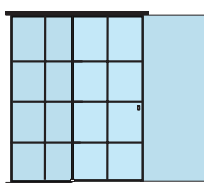

A + B + C

FALSO TECHO CON VIDRIO FIJO  
FALSE CEILING WITH FIXED GLASS  
FAUX-PLAFOND AVEC VERRE FIXE

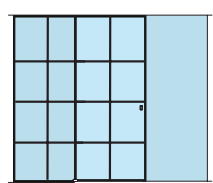

A + B + C

Compact Glass



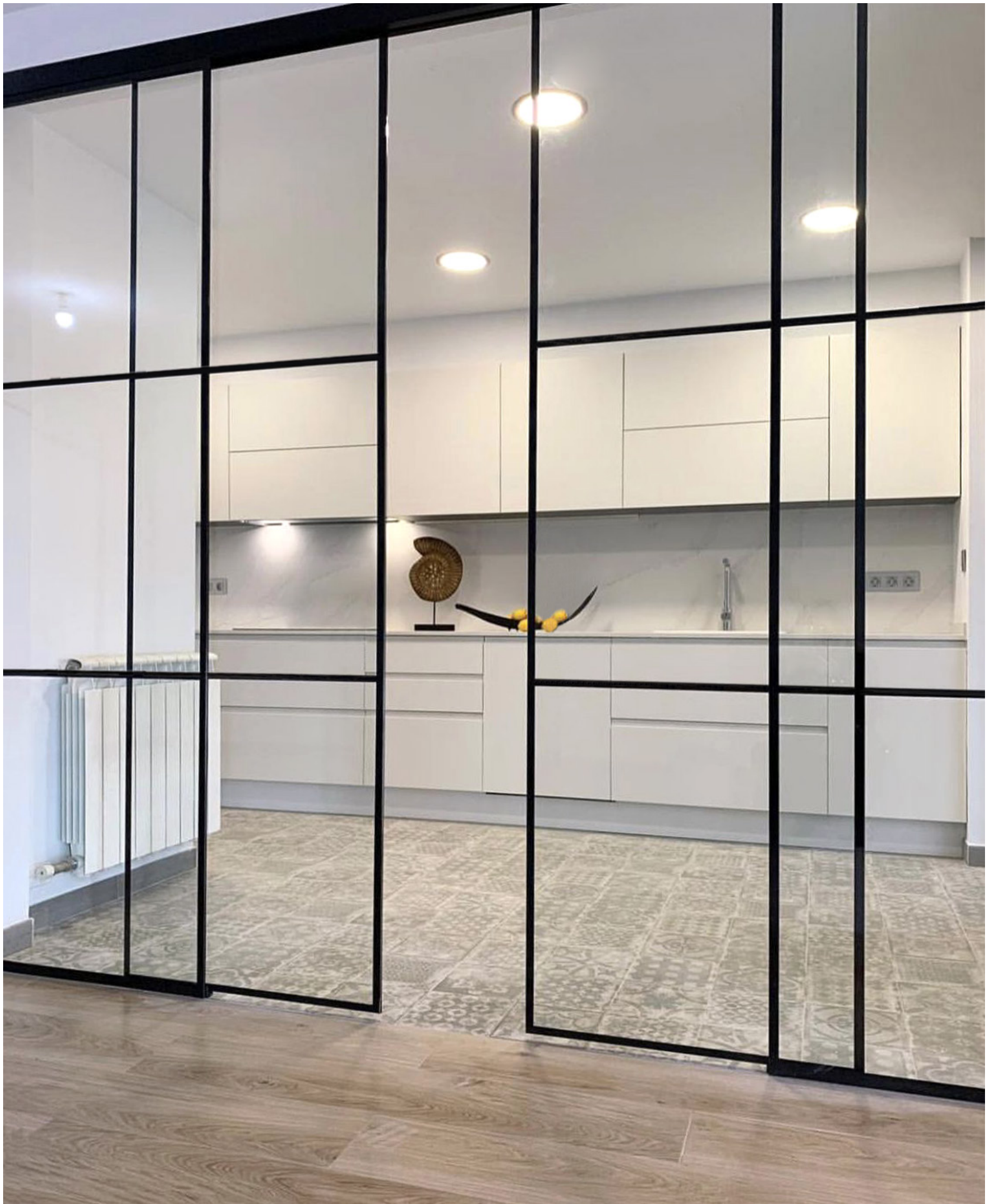

**Accesorio Frame Flat Glass**

# FRAME FLAT GLASS



## ES

### PERSONALIDAD DÓNDE Y CÓMO QUIERAS

Los accesorios también evolucionan y bajo el mismo concepto de la Familia Frame by Saheco, presentamos Frame Flat: serie de perfiles en formato pletina que dará un look chic minimal industrial a las instalaciones de puertas correderas y fijas.

¿Que ofrece esta modalidad de perfiles?

- 1. Dos únicos perfiles** de aluminio:
  - Perfil perimetral para enmarcar para grosores de vidrio de 10mm.
  - Perfil división interna único: mismo grosor de perfil a ambos lados de la puerta para conseguir una simetría visual.
- 2. Infinidad de diseños** gracias al formato de venta en perfiles individuales.
- 3. Se sirve con cinta adhesiva de doble cara** de alta calidad para un montaje rápido y limpio.
- 4. Disponible en acabado lacado blanco y negro mate.**
- 5. Compatible con todos los sistemas de vidrio de la oferta Saheco:** divisiones y puertas de paso correderas, telescópicas y sincronizadas; sistema de ducha de uso doméstico y muebles y armarios.

## EN

### PERSONALIZATION WHERE AND HOWEVER YOU WANT IT

The accessories also evolve in time, and under the same concept of the Frame range by Saheco, we introduce Frame Flat: a set of flat profiles that give a minimalistic industrial look to any sliding or fixed glass panels installation.

What do these profiles offer?

- 1. Two single aluminum profiles:**
  - U-Channel profile for perimeter framing, for glass thicknesses of 10mm.
  - Flat profile for internal grids: same profile thickness on both sides of the door to achieve visual symmetry.
- 2. Limitless designs** thanks to the sales format in individual unit profiles.
- 3. Supplied with high-quality double-sided adhesive tape**, for a quick and clean installation.
- 4. Available in finish matt white and black lacquered aluminium.**
- 5. Compatible with all of Saheco's glass systems:** sliding, telescopic and synchronized partitions and doors; shower system for domestic use and furniture and cabinets.

## FR

### PERSONNALITÉ OÙ ET COMME VOUS LE SOUHAITEZ

Les accessoires évoluent également et sous le même concept de la famille Frame by Saheco, nous présentons Frame Flat : une série de profils en format platine qui donneront un aspect industriel minimal chic aux installations de portes coulissantes et fixes.

Qu'est-ce que ce type de profilé peut offrir?

- 1. Deux profils simples** en aluminium:
  - Profilé d'encadrement périphérique pour une épaisseur de verre de 10 mm.
  - Profilé interne unique en deux parties: même épaisseur du profilé des deux côtés de la porte pour une symétrie visuelle.
- 2. Des conceptions infinies** grâce au format de vente en profils individuels.
- 3. Fourni avec un ruban adhésif double face** de haute qualité pour un montage rapide et propre.
- 4. Disponible en laqué blanc et noir mat.**
- 5. Compatible avec tous les systèmes de vitrage de la gamme Saheco:** cloisons et portes intérieures coulissantes, télescopiques et synchronisées; systèmes de douche domestiques et meubles et armoires.



## Variantes de instalación

Installation variants | Variantes d'installation

**GUIADOR INFERIOR FRAME FLAT**  
FRAME FLAT BOTTOM GUIDE  
GUIDE INFÉRIEUR FRAME FLAT

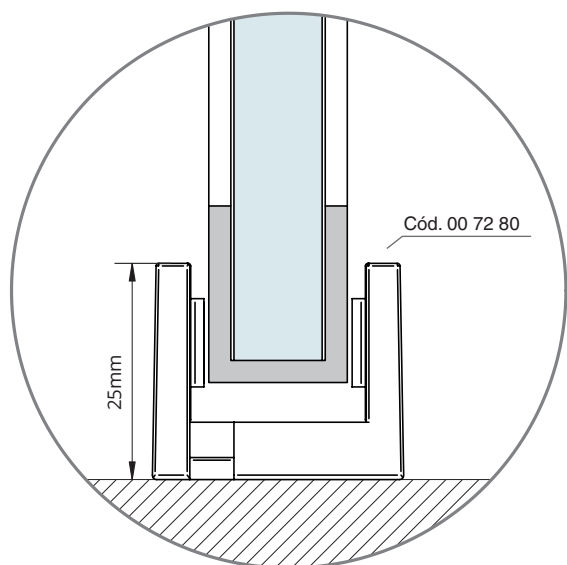



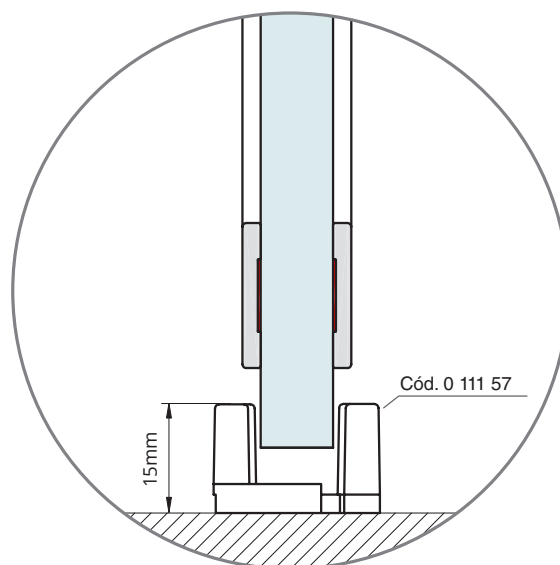







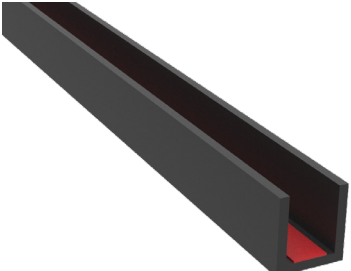

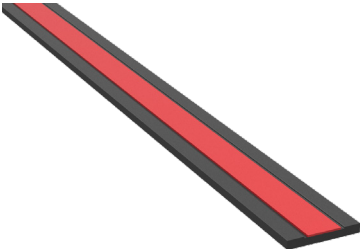
**GUIADOR INFERIOR PLÁSTICO FRAME**  
PLASTIC FRAME BOTTOM GUIDE  
FRAME GUIDE INFÉRIEUR PLASTIQUE

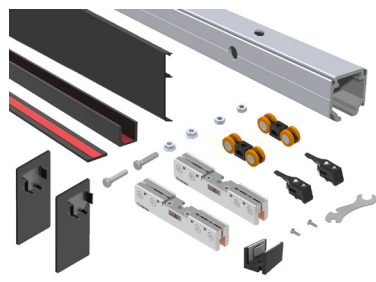

# Accesorio Frame Flat

## Frame Flat Accessory | Accessoire Frame Flat

ACCESORIO FRAME FLAT   FRAME FLAT ACCESSORY   ACCESSOIRE FRAME FLAT		Finish	Cód.		
 <p>Perfil perimetral <b>FRAME FLAT</b> FRAME FLAT perimeter track Rail périmétral FRAME FLAT</p> <p>10 mm  18,4x20mm</p> <p>*Para vidrio de 12mm consultar *For 12mm glass consult *Pour le verre de 12 mm, consulter</p>	<p><b>BL</b></p> <p>0 111 70<sup>1</sup></p> <p>3 m</p>	<p>6 perfiles 6 profiles 6 profils</p>			
	<p><b>WL</b></p> <p>0 111 71<sup>1</sup></p> <p>3 m</p>				
 <p>Perfil división interna <b>FRAME FLAT</b> FRAME FLAT Internal division track Rail division interne FRAME FLAT</p> <p> 20x2,5mm</p>	<p><b>BL</b></p> <p>0 111 72<sup>1</sup></p> <p>3 m</p>	<p>6 perfiles 6 profiles 6 profils</p>			
	<p><b>WL</b></p> <p>0 111 73<sup>1</sup></p> <p>3 m</p>				
 <p>Guiador inferior <b>FRAME FLAT</b> FRAME FLAT bottom guide Guide inférieur FRAME FLAT</p>	<p><b>BL</b></p> <p>00 72 80</p>	<p>1 pieza 1 piece 1 pièce</p>			
	<p><b>WL</b></p> <p>00 72 90</p>				
 <p>Guiador inferior plástico FRAME Plastic FRAME bottom guide FRAME guide inferior plastique</p>	<p><b>TP</b></p> <p>0 111 57</p>	<p>25 piezas 25 pieces 25 pièces</p>			
	<p><b>BP</b></p> <p>00 49 57</p>				
KITS   KITS   KITS		Finish	Cód.		
 <p>Kit <b>SV-P70</b> + Perfilera <b>FRAME FLAT</b>. x2 Freno retenedor. SV-P70 Kit + FRAME FLAT profiles. x2 Retaining brake. Kit SV-P70 + Profils FRAME FLAT. x2 Freins de retenue.</p> <p>70kg  33x33mm  RODAMIENTO A BOLAS BALL BEARING ROULEMENT À BILLES</p>	<p><b>BL</b></p> <p>0 981 77</p> <p>2 m</p>	<p>1 kit 1 jeu</p>			

<sup>1</sup> Se sirve con cinta adhesiva | Served with double-sided tape | Est servi avec ruban adhésif double face

**TP** Plástico transparente  
Transparent plastic  
Plastique transparent

**BP** Plástico negro  
Black plastic  
Plastique noir

**BL** Aluminio lacado negro mate  
Matt black lacquered aluminium  
Aluminium anodisé laqué noir mat

**WL** Aluminio lacado blanco mate  
Matt white lacquered aluminium  
Aluminium laqué blanc mat









## **Demostrativos**

Display stands

Présentoirs

## Demostrativos

Display stands | Présentoirs

DEMOSTRATIVOS   DISPLAY STANDS   PRÉSENTOIRS		Acabado	Cód.		
	Frame	  	00 11 20 00 11 21 00 11 25		1 pieza 1 piece 1 pièce



**Aluminio anodizado plata mate**  
Satin anodized aluminium  
Aluminium anodisé argent

WL

**Aluminio lacado blanco mate**  
Matt white lacquered aluminium  
Aluminium anodisé laqué blanc mat

BL

**Aluminio lacado negro mate**  
Matt black lacquered aluminium  
Aluminium anodisé laqué noir mat



## **Maletas demostrativas**

Commercial suitcases

Valises commerciales

## Maletas demostrativas

Commercial suitcases | Valises commerciales

MALETAS   SUITCASES   VALISES	Acabado	Cód.		
 <p>Expo-maleta vacía Empty commercial suitcase Valise commerciale vide</p> <p>* Contenido a definir según pedido   Content to be defined upon request   Contenu à définir sur demande</p>		00 10 99		1 pieza 1 piece 1 pièce
 <p>Expo-maleta <b>Essential Glass</b> Essential Glass commercial suitcase Valise commerciale Essential Glass</p>		00 99 64		1 pieza 1 piece 1 pièce
 <p>Expo-maleta <b>Compact Glass SV-X70 / SV-X110</b> SV-X70 / SV-X110 Compact Glass commercial suitcase Valise commerciale Compact Glass SV-X70 / SV-X110</p>		00 99 62		1 pieza 1 piece 1 pièce
 <p>Expo-maleta <b>Vaho Glass SV-X50</b> SV-X50 Vaho Glass commercial suitcase Valise commerciale Vaho Glass SV-X50</p>		99 99 68		1 pieza 1 piece 1 pièce

**Sistemas puertas correderas**  
Sliding door fittings  
Systèmes portes coulissantes

# GLASS



**Download the catalog**



Polígono Industrial de Foradada / 08580  
St. Quirze de Besora / Barcelona / Spain  
T +34 93 852 92 23  
saheco@saheco.com

**Export contact details**  
T +34 93 852 96 15  
export@saheco.com

[saheco.com](http://saheco.com)

Portada: Proyecto by Onside Estudio de arquitectura.