

Mod. 9 SHELF BRACKET

SUPPORTS

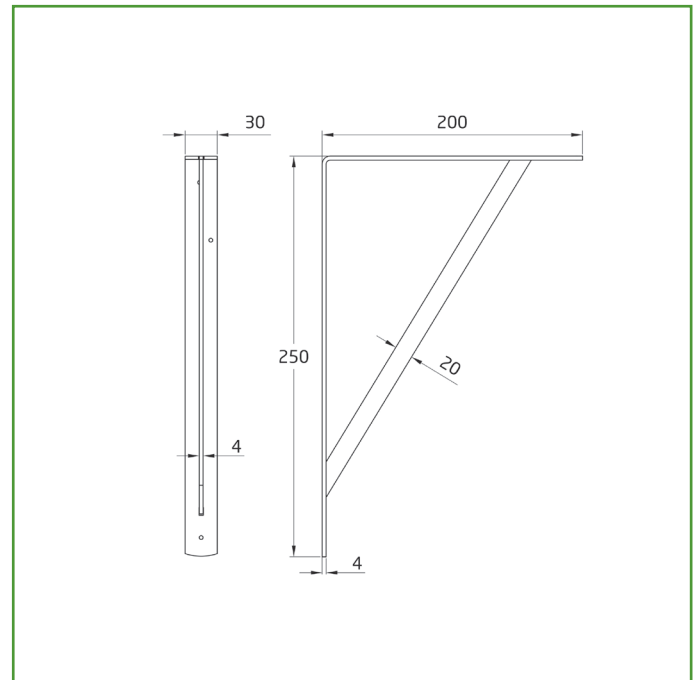

Measurements: 250 x 200 mm

Material: Steel

Finish: Silver grey

Code: 9806

Presentation: With individual EAN

EAN unit: 8413023098060



Features

Support made of high quality steel. Reinforced, robust and functional design. Suitable to support high loads. Allows you to expand storage space.

Assembly instructions / Utilities

The wall bracket is a versatile, resistant and easy-to-install product that offers a practical and durable solution for installing shelves in any space.

Ecofriendly

At AMIG we aim to offer the best quality in our products without harming the environment. For this reason, we work to comply at all times with environmental regulations in our processes, as well as by implementing the Comprehensive Management System (SIG) for packaging waste.

Care and cleaning

Clean with a dry cloth. Do not use abrasive and/or corrosive products, detergents, solvents or alcohols.

Product Logistics: 

Product Length (cm):	17
Product width (cm):	4
Product height (cm):	3,2
Product weight (gr):	510

Packaging data: 

Servings per Innerbox:	4
Innerbox length (cm):	25,7
Innerbox width (cm):	20,8
Innerbox height (cm):	6,2
Innerbox weight (Kg):	2,2
Innerbox EAN:	8413023498068

Amount per cartonbox:	16
Cartonbox length (cm):	27,5
Cartonbox width (cm):	22,5
Cartonbox height (cm):	27
Cartonbox weight (Kg):	9,3
Cartonbox EAN:	8413023798069

